



Robotics

N. Marchand

Introduction

Outline

Mechanics

Kinematics

- Arm robots
- Inner-loop
- Geometrical model
- Kinematic model
- Dynamical model
- Conclusion

Path planning

- Workspace and obstacles
- path planning

Mobile robotics

Visual servoing

RX90 robot

Robotics

Nicolas Marchand

Nicolas.Marchand@gipsa-lab.fr

Control Systems Department, **gipsa-lab**
Grenoble, France



ENSE3-ASI

INTRODUCTION

Robotics

N. Marchand

Introduction

Outline

Mechanics

Kinematics

- Arm robots
- Inner-loop
- Geometrical model
- Kinematic model
- Dynamical model
- Conclusion

Path planning

- Workspace and obstacles
- path planning

Mobile robotics

Visual servoing

RX90 robot

- Historical perspective

- First use of the word Robot (means forced labor or serf in Czech) in the play R.U.R. (Rossum's Universal Robots) by Karel Capek (1890-1938) in January 1921.

In R.U.R., Capek poses a paradise, where the machines initially bring so many benefits but in the end bring an equal amount of blight in the form of unemployment and social unrest

- Science fiction

- Often a bad image: men against robots, dystopic society, etc. More and more a good image.



Metropolis, Fritz Lang, 1927

Formal definition (Robot Institute of America)

A reprogrammable, multifunctional manipulator designed to move material, parts, tools, or specialized devices through various programmed motions for the performance of a variety of tasks

ROBOTS AND THEIR IMAGE

Robotics

N. Marchand

Introduction

Outline

Mechanics

Kinematics

- Arm robots
- Inner-loop
- Geometrical model
- Kinematic model
- Dynamical model
- Conclusion

Path planning

- Workspace and obstacles
- path planning

Mobile robotics

Visual servoing

RX90 robot

- Robots have a bad image (1930-1960)
 - Robots take human works
 - Robots are dangerous since potentially independent and more intelligent than we are
- Robots have a better image (1960-today)
 - Robots can make things that human can not do (space, etc.)
 - Human can do things that robots can not do (we still are clever)
 - Robots can be games
 - Robots can be good or bad



ROBOTICS INDUSTRY (1/MANY)

Robotics

- Number of robots for every 10 000 workers:

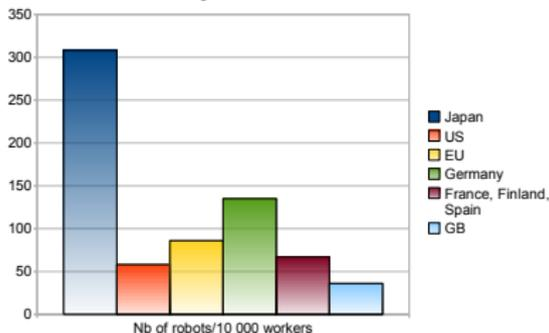

- 70% of robots in companies with more than 1000 employees
- 17% of robots in companies with less than 300 employees
- In 2002, 95% of robots > 30k€ and 32% of robots > 60k€
- 79% of decrease of the mean price between 1990 and 2002
- Big robots manufacturers: ABB (S), KUKA (G), Fanuc (JP), etc.

N. Marchand

Introduction

Outline

Mechanics

Kinematics

Arm robots

Inner-loop

Geometrical model

Kinematic model

Dynamical model

Conclusion

Path planning

Workspace and obstacles

path planning

Mobile robotics

Visual servoing

RX90 robot

ROBOTICS INDUSTRY (2/MANY)

Robotics

N. Marchand

Introduction

Outline

Mechanics

Kinematics

- Arm robots
- Inner-loop
- Geometrical model
- Kinematic model
- Dynamical model
- Conclusion

Path planning

- Workspace and obstacles
- path planning

Mobile robotics

Visual servoing

RX90 robot

● Where are the robots ?

● France:

- 61% in automotive industry
- 14% in chemical industry
- ...
- 4% in electricity industry
- 3% in food industry



● What kind of robots ?

- Industry: ground fixed robots: manipulators, arm robots, ...
- Private individuals: mobile robots: service, games, ...

● Future of robots:

- Industrial mobile robotics
- Medical robotics
- Service robots (growing field)



ROBOTICS INDUSTRY (3/MANY)

Robotics

N. Marchand

Introduction

Outline

Mechanics

Kinematics

- Arm robots
- Inner-loop
- Geometrical model
- Kinematic model
- Dynamical model
- Conclusion

Path planning

- Workspace and obstacles
- path planning

Mobile robotics

Visual servoing

RX90 robot



Vacuum cleaner (Kärcher)



Forest robot



Kuka robot for automotive industry

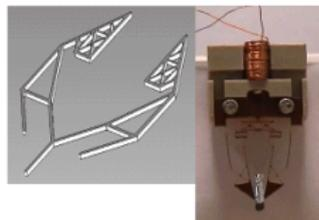

Micromanipulator

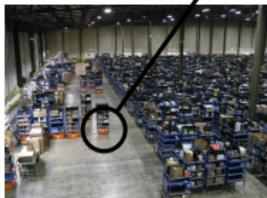

Surgical robot



Hollywood robots

ROBOTICS INDUSTRY (4/MANY)

Robotics

- Past

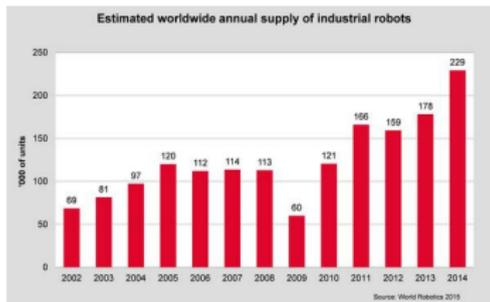

- Future

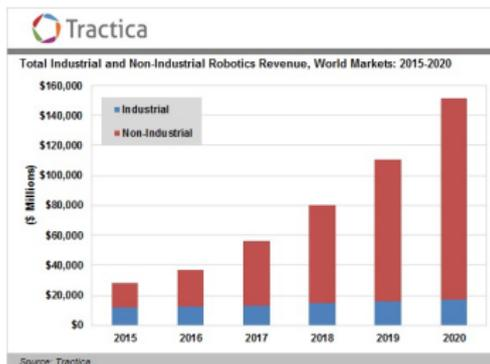

N. Marchand

Introduction

Outline

Mechanics

Kinematics

Arm robots

Inner-loop

Geometrical model

Kinematic model

Dynamical model

Conclusion

Path planning

Workspace and obstacles

path planning

Mobile

robotics

Visual

servoing

RX90 robot

ROBOTICS INDUSTRY: UAVs (5/MANY)

Robotics

UAV's Manufacturer

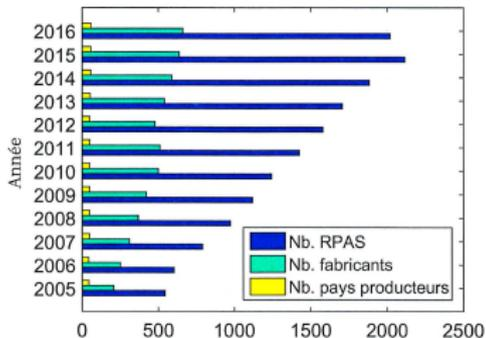

UAVs by countries

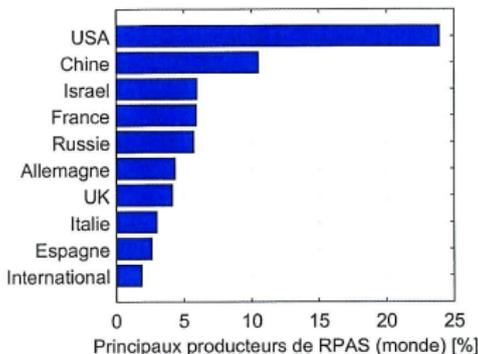

N. Marchand

Introduction

Outline

Mechanics

Kinematics

Arm robots

Inner-loop

Geometrical model

Kinematic model

Dynamical model

Conclusion

Path planning

Workspace and obstacles path planning

Mobile robotics

Visual servoing

RX90 robot

ROBOTICS INDUSTRY: UAVs (6/MANY)

Robotics

- Publications indicates future ?

N. Marchand

Introduction

Outline

Mechanics

Kinematics

Arm robots

Inner-loop

Geometrical model

Kinematic model

Dynamical model

Conclusion

Path planning

Workspace and obstacles

path planning

Mobile robotics

Visual servoing

RX90 robot

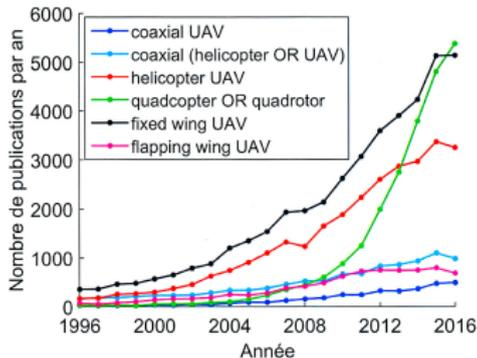

- By keywords

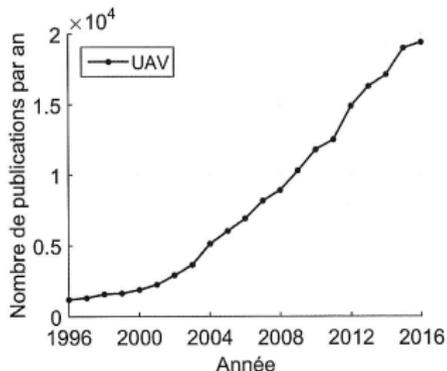

OUTLINE

Robotics

N. Marchand

Introduction

Outline

Mechanics

Kinematics

Arm robots
Inner-loop
Geometrical
model
Kinematic model
Dynamical
model
Conclusion

Path planning

Workspace and
obstacles
path planning

Mobile
robotics

Visual
servoing

RX90 robot

- Basic mechanics for robotics
 - Space representation
frames, coordinate transformation, etc.
 - Force and torques
- Modelisation
- Control for robots
 - All potential problems:
Oscillations, dry friction, saturations, etc.
 - Linear approaches
 - Nonlinear approaches

Robotics

N. Marchand

Introduction

Outline

Mechanics

Kinematics

Arm robots

Inner-loop

Geometrical
model

Kinematic model

Dynamical
model

Conclusion

Path planning

Workspace and
obstacles

path planning

Mobile

robotics

Visual

servoing

RX90 robot

- 1 Introduction
- 2 Outline
- 3 Mechanics basis
- 4 Kinematics and dynamics of robots
 - Arm robots
 - Inner-loop
 - Geometrical model
 - Kinematic model
 - Dynamical model
 - Conclusion
- 5 Path planning
 - Workspace and obstacles
 - Path planning problem formulation
- 6 Mobile robotics
- 7 Visual servoing
- 8 Stäubli RX90 robot

POSITION AND SPEED IN A FIXED FRAME

Robotics

N. Marchand

Introduction

Outline

Mechanics

Kinematics

Arm robots

Inner-loop

Geometrical
model

Kinematic model

Dynamical
model

Conclusion

Path planning

Workspace and
obstacles
path planningMobile
roboticsVisual
servoing

RX90 robot

- The **position** of some point P in the **fixed** frame $\mathcal{F}(o, \vec{e}_x, \vec{e}_y, \vec{e}_z)$ is the vector $\rho = (x, y, z)^T$

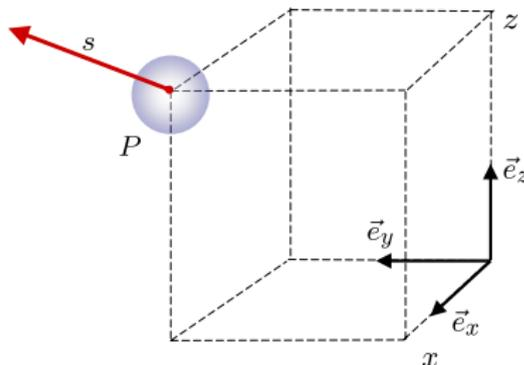



POSITION AND SPEED IN A FIXED FRAME

Robotics

N. Marchand

Introduction

Outline

Mechanics

Kinematics

Arm robots
Inner-loop
Geometrical model
Kinematic model
Dynamical model
Conclusion

Path planning

Workspace and obstacles
path planning

Mobile robotics

Visual servoing

RX90 robot

- The **position** of some point P in the **fixed** frame $\mathcal{F}(o, \vec{e}_x, \vec{e}_y, \vec{e}_z)$ is the vector $\rho = (x, y, z)^T$
- The **speed** of P in \mathcal{F} is the vector $s = \dot{\rho} = (\dot{x}, \dot{y}, \dot{z})^T$

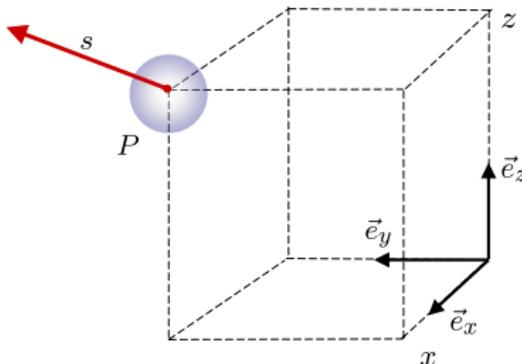



ROTATIONS AND ASSOCIATED TOOLS

- A rotation is represented by a 3×3 matrix R such that $R^T = R^{-1}$ and $\det R = 1$

Robotics

N. Marchand

Introduction

Outline

Mechanics

Kinematics

Arm robots
Inner-loop
Geometrical
model
Kinematic model
Dynamical
model
Conclusion

Path planning

Workspace and
obstacles
path planning

Mobile
robotics

Visual
servoing

RX90 robot



ROTATIONS AND ASSOCIATED TOOLS

- A rotation is represented by a 3×3 matrix R such that $R^T = R^{-1}$ and $\det R = 1$
- A **rotation** of angle θ around:

Robotics

N. Marchand

Introduction

Outline

Mechanics

Kinematics

- Arm robots
- Inner-loop
- Geometrical model
- Kinematic model
- Dynamical model
- Conclusion

Path planning

- Workspace and obstacles
- path planning

Mobile robotics

Visual servoing

RX90 robot



ROTATIONS AND ASSOCIATED TOOLS

Robotics

- A rotation is represented by a 3×3 matrix R such that $R^T = R^{-1}$ and $\det R = 1$
- A **rotation** of angle θ around:

- axis \vec{e}_x is given by:

$$\begin{pmatrix} 1 & 0 & 0 \\ 0 & \cos \theta & -\sin \theta \\ 0 & \sin \theta & \cos \theta \end{pmatrix}$$

N. Marchand

Introduction

Outline

Mechanics

Kinematics

- Arm robots
- Inner-loop
- Geometrical model
- Kinematic model
- Dynamical model
- Conclusion

Path planning

- Workspace and obstacles
- path planning

Mobile robotics

Visual servoing

RX90 robot



ROTATIONS AND ASSOCIATED TOOLS

Robotics

N. Marchand

Introduction

Outline

Mechanics

Kinematics

- Arm robots
- Inner-loop
- Geometrical model
- Kinematic model
- Dynamical model
- Conclusion

Path planning

- Workspace and obstacles
- path planning

Mobile robotics

Visual servoing

RX90 robot

- A rotation is represented by a 3×3 matrix R such that $R^T = R^{-1}$ and $\det R = 1$
- A **rotation** of angle θ around:

- axis \vec{e}_x is given by:

$$\begin{pmatrix} 1 & 0 & 0 \\ 0 & \cos \theta & -\sin \theta \\ 0 & \sin \theta & \cos \theta \end{pmatrix}$$

- axis \vec{e}_y is given by:

$$\begin{pmatrix} \cos \theta & 0 & \sin \theta \\ 0 & 1 & 0 \\ -\sin \theta & 0 & \cos \theta \end{pmatrix}$$



ROTATIONS AND ASSOCIATED TOOLS

Robotics

N. Marchand

Introduction

Outline

Mechanics

Kinematics

Arm robots

Inner-loop

Geometrical
model

Kinematic model

Dynamical
model

Conclusion

Path planning

Workspace and
obstacles

path planning

Mobile robotics

Visual servoing

RX90 robot

- A rotation is represented by a 3×3 matrix R such that $R^T = R^{-1}$ and $\det R = 1$
- A **rotation** of angle θ around:

- axis \vec{e}_x is given by:

$$\begin{pmatrix} 1 & 0 & 0 \\ 0 & \cos \theta & -\sin \theta \\ 0 & \sin \theta & \cos \theta \end{pmatrix}$$

- axis \vec{e}_y is given by:

$$\begin{pmatrix} \cos \theta & 0 & \sin \theta \\ 0 & 1 & 0 \\ -\sin \theta & 0 & \cos \theta \end{pmatrix}$$

- axis \vec{e}_z is given by:

$$\begin{pmatrix} \cos \theta & -\sin \theta & 0 \\ \sin \theta & \cos \theta & 0 \\ 0 & 0 & 1 \end{pmatrix}$$



ROTATIONS AND ASSOCIATED TOOLS

Robotics

N. Marchand

Introduction

Outline

Mechanics

Kinematics

Arm robots

Inner-loop

Geometrical
model

Kinematic model

Dynamical
model

Conclusion

Path planning

Workspace and
obstacles

path planning

Mobile

robotics

Visual

servoing

RX90 robot

- A rotation is represented by a 3×3 matrix R such that $R^T = R^{-1}$ and $\det R = 1$
- A **rotation** of angle θ around:

- axis \vec{e}_x is given by:

$$\begin{pmatrix} 1 & 0 & 0 \\ 0 & \cos \theta & -\sin \theta \\ 0 & \sin \theta & \cos \theta \end{pmatrix}$$

- axis \vec{e}_y is given by:

$$\begin{pmatrix} \cos \theta & 0 & \sin \theta \\ 0 & 1 & 0 \\ -\sin \theta & 0 & \cos \theta \end{pmatrix}$$

- axis \vec{e}_z is given by:

$$\begin{pmatrix} \cos \theta & -\sin \theta & 0 \\ \sin \theta & \cos \theta & 0 \\ 0 & 0 & 1 \end{pmatrix}$$

- a unit vector $\vec{u} = (u_x, u_y, u_z)^T$:

$$\begin{pmatrix} u_x^2 + (1 - u_x^2)c_\theta & u_x u_y(1 - c_\theta) - u_z s_\theta & u_x u_z(1 - c_\theta) + u_y s_\theta \\ u_x u_y(1 - c_\theta) + u_z s_\theta & u_y^2 + (1 - u_y^2)c_\theta & u_y u_z(1 - c_\theta) - u_x s_\theta \\ u_x u_z(1 - c_\theta) - u_y s_\theta & u_y u_z(1 - c_\theta) + u_x s_\theta & u_z^2 + (1 - u_z^2)c_\theta \end{pmatrix}$$



ROTATIONS AND ASSOCIATED TOOLS

Robotics

- A rotation is represented by a 3×3 matrix R such that $R^T = R^{-1}$ and $\det R = 1$
- A **rotation** of angle θ around:

- axis \vec{e}_x is given by:

$$\begin{pmatrix} 1 & 0 & 0 \\ 0 & \cos \theta & -\sin \theta \\ 0 & \sin \theta & \cos \theta \end{pmatrix}$$

- axis \vec{e}_y is given by:

$$\begin{pmatrix} \cos \theta & 0 & \sin \theta \\ 0 & 1 & 0 \\ -\sin \theta & 0 & \cos \theta \end{pmatrix}$$

- axis \vec{e}_z is given by:

$$\begin{pmatrix} \cos \theta & -\sin \theta & 0 \\ \sin \theta & \cos \theta & 0 \\ 0 & 0 & 1 \end{pmatrix}$$

- a unit vector $\vec{u} = (u_x, u_y, u_z)^T$:

$$\begin{pmatrix} u_x^2 + (1 - u_x^2)c_\theta & u_x u_y(1 - c_\theta) - u_z s_\theta & u_x u_z(1 - c_\theta) + u_y s_\theta \\ u_x u_y(1 - c_\theta) + u_z s_\theta & u_y^2 + (1 - u_y^2)c_\theta & u_y u_z(1 - c_\theta) - u_x s_\theta \\ u_x u_z(1 - c_\theta) - u_y s_\theta & u_y u_z(1 - c_\theta) + u_x s_\theta & u_z^2 + (1 - u_z^2)c_\theta \end{pmatrix}$$

- The coordinates q of point Q obtained by rotating P with rotation R is $q = Rp$



ROTATIONS AND ASSOCIATED TOOLS

Robotics

N. Marchand

Introduction

Outline

Mechanics

Kinematics

Arm robots

Inner-loop

Geometrical
model

Kinematic model

Dynamical
model

Conclusion

Path planning

Workspace and
obstacles

path planning

Mobile robotics

Visual servoing

RX90 robot

- A rotation is represented by a 3×3 matrix R such that $R^T = R^{-1}$ and $\det R = 1$
- A **rotation** of angle θ around:

- axis \vec{e}_x is given by:

$$\begin{pmatrix} 1 & 0 & 0 \\ 0 & \cos \theta & -\sin \theta \\ 0 & \sin \theta & \cos \theta \end{pmatrix}$$

- axis \vec{e}_y is given by:

$$\begin{pmatrix} \cos \theta & 0 & \sin \theta \\ 0 & 1 & 0 \\ -\sin \theta & 0 & \cos \theta \end{pmatrix}$$

- axis \vec{e}_z is given by:

$$\begin{pmatrix} \cos \theta & -\sin \theta & 0 \\ \sin \theta & \cos \theta & 0 \\ 0 & 0 & 1 \end{pmatrix}$$

- a unit vector $\vec{u} = (u_x, u_y, u_z)^T$:

$$\begin{pmatrix} u_x^2 + (1 - u_x^2)c_\theta & u_x u_y(1 - c_\theta) - u_z s_\theta & u_x u_z(1 - c_\theta) + u_y s_\theta \\ u_x u_y(1 - c_\theta) + u_z s_\theta & u_y^2 + (1 - u_y^2)c_\theta & u_y u_z(1 - c_\theta) - u_x s_\theta \\ u_x u_z(1 - c_\theta) - u_y s_\theta & u_y u_z(1 - c_\theta) + u_x s_\theta & u_z^2 + (1 - u_z^2)c_\theta \end{pmatrix}$$

- The coordinates q of point Q obtained by rotating P with rotation R is $q = Rp$
- The rotation resulting from 2 successive rotations R_1 and then R_2 is $R_2 R_1$



PRODUCTS AND ASSOCIATED TOOLS

- The **scalar product** $\langle v_1, v_2 \rangle$ is defined by: $\langle v_1, v_2 \rangle := v_1^T v_2 \in \mathbb{R}$

Robotics

N. Marchand

Introduction

Outline

Mechanics

Kinematics

Arm robots
Inner-loop
Geometrical
model
Kinematic model
Dynamical
model
Conclusion

Path planning

Workspace and
obstacles
path planning

Mobile
robotics

Visual
servoing

RX90 robot



PRODUCTS AND ASSOCIATED TOOLS

Robotics

- The **scalar product** $\langle v_1, v_2 \rangle$ is defined by: $\langle v_1, v_2 \rangle := v_1^T v_2 \in \mathbb{R}$
- The **cross product** $v_1 \times v_2$ is defined by:

$$v_1 \times v_2 := \begin{pmatrix} v_{1y}v_{2z} - v_{1z}v_{2y} \\ v_{1z}v_{2x} - v_{1x}v_{2z} \\ v_{1x}v_{2y} - v_{1y}v_{2x} \end{pmatrix} \in \mathbb{R}^3$$

N. Marchand

Introduction

Outline

Mechanics

Kinematics

Arm robots
Inner-loop
Geometrical
model
Kinematic model
Dynamical
model
Conclusion

Path planning

Workspace and
obstacles
path planning

Mobile
robotics

Visual
servoing

RX90 robot



PRODUCTS AND ASSOCIATED TOOLS

Robotics

- The **scalar product** $\langle v_1, v_2 \rangle$ is defined by: $\langle v_1, v_2 \rangle := v_1^T v_2 \in \mathbb{R}$
- The **cross product** $v_1 \times v_2$ is defined by:

N. Marchand

$$v_1 \times v_2 := \begin{pmatrix} v_{1y}v_{2z} - v_{1z}v_{2y} \\ v_{1z}v_{2x} - v_{1x}v_{2z} \\ v_{1x}v_{2y} - v_{1y}v_{2x} \end{pmatrix} \in \mathbb{R}^3$$

Introduction

Outline

Mechanics

Kinematics

Arm robots

Inner-loop

Geometrical
model

Kinematic model

Dynamical
model

Conclusion

- The **skew-symmetric matrix** associated to a vector $p = (x, y, z)^T$ is:

$$p^\times := \begin{pmatrix} 0 & -z & y \\ z & 0 & -x \\ -y & x & 0 \end{pmatrix}$$

Path planning

Workspace and
obstacles

path planning

Mobile

robotics

Visual

servoing

RX90 robot



PRODUCTS AND ASSOCIATED TOOLS

Robotics

- The **scalar product** $\langle v_1, v_2 \rangle$ is defined by: $\langle v_1, v_2 \rangle := v_1^T v_2 \in \mathbb{R}$
- The **cross product** $v_1 \times v_2$ is defined by:

$$v_1 \times v_2 := \begin{pmatrix} v_{1y}v_{2z} - v_{1z}v_{2y} \\ v_{1z}v_{2x} - v_{1x}v_{2z} \\ v_{1x}v_{2y} - v_{1y}v_{2x} \end{pmatrix} \in \mathbb{R}^3$$

N. Marchand

Introduction

Outline

Mechanics

Kinematics

- Arm robots
- Inner-loop
- Geometrical model
- Kinematic model
- Dynamical model
- Conclusion

Path planning

- Workspace and obstacles
- path planning

Mobile robotics

Visual servoing

RX90 robot

- The **skew-symmetric matrix** associated to a vector $p = (x, y, z)^T$ is:

$$p^\times := \begin{pmatrix} 0 & -z & y \\ z & 0 & -x \\ -y & x & 0 \end{pmatrix}$$

- The set of skew-symmetric matrix with the brackett $[M_1, M_2] = M_1M_2 - M_2M_1$ is called $SO(3)$ and forms an algebra



PRODUCTS AND ASSOCIATED TOOLS

Robotics

- The **scalar product** $\langle v_1, v_2 \rangle$ is defined by: $\langle v_1, v_2 \rangle := v_1^T v_2 \in \mathbb{R}$
- The **cross product** $v_1 \times v_2$ is defined by:

N. Marchand

$$v_1 \times v_2 := \begin{pmatrix} v_{1y}v_{2z} - v_{1z}v_{2y} \\ v_{1z}v_{2x} - v_{1x}v_{2z} \\ v_{1x}v_{2y} - v_{1y}v_{2x} \end{pmatrix} \in \mathbb{R}^3$$

Introduction

Outline

Mechanics

- The **skew-symmetric matrix** associated to a vector $p = (x, y, z)^T$ is:

$$p^\times := \begin{pmatrix} 0 & -z & y \\ z & 0 & -x \\ -y & x & 0 \end{pmatrix}$$

Kinematics

Arm robots

Inner-loop

Geometrical model

Kinematic model

Dynamical model

Conclusion

- The set of skew-symmetric matrix with the brackett $[M_1, M_2] = M_1M_2 - M_2M_1$ is called $SO(3)$ and forms an algebra
- **Skew-symmetric matrices and cross product:**

Path planning

Workspace and obstacles

path planning

Mobile

robotics

Visual

servoing

RX90 robot



PRODUCTS AND ASSOCIATED TOOLS

Robotics

- The **scalar product** $\langle v_1, v_2 \rangle$ is defined by: $\langle v_1, v_2 \rangle := v_1^T v_2 \in \mathbb{R}$
- The **cross product** $v_1 \times v_2$ is defined by:

$$v_1 \times v_2 := \begin{pmatrix} v_{1y}v_{2z} - v_{1z}v_{2y} \\ v_{1z}v_{2x} - v_{1x}v_{2z} \\ v_{1x}v_{2y} - v_{1y}v_{2x} \end{pmatrix} \in \mathbb{R}^3$$

N. Marchand

Introduction

Outline

Mechanics

Kinematics

Arm robots

Inner-loop

Geometrical
model

Kinematic model

Dynamical
model

Conclusion

Path planning

Workspace and
obstacles

path planning

Mobile
roboticsVisual
servoing

RX90 robot

- The **skew-symmetric matrix** associated to a vector $p = (x, y, z)^T$ is:

$$p^\times := \begin{pmatrix} 0 & -z & y \\ z & 0 & -x \\ -y & x & 0 \end{pmatrix}$$

- The set of skew-symmetric matrix with the brackett $[M_1, M_2] = M_1M_2 - M_2M_1$ is called $SO(3)$ and forms an algebra
- Skew-symmetric matrices and cross product:

$$v^\times u = v \times u$$



PRODUCTS AND ASSOCIATED TOOLS

Robotics

- The **scalar product** $\langle v_1, v_2 \rangle$ is defined by: $\langle v_1, v_2 \rangle := v_1^T v_2 \in \mathbb{R}$
- The **cross product** $v_1 \times v_2$ is defined by:

$$v_1 \times v_2 := \begin{pmatrix} v_{1y}v_{2z} - v_{1z}v_{2y} \\ v_{1z}v_{2x} - v_{1x}v_{2z} \\ v_{1x}v_{2y} - v_{1y}v_{2x} \end{pmatrix} \in \mathbb{R}^3$$

N. Marchand

Introduction

Outline

Mechanics

Kinematics

Arm robots

Inner-loop

Geometrical
model

Kinematic model

Dynamical
model

Conclusion

Path planning

Workspace and
obstacles

path planning

Mobile

robotics

Visual

servoing

RX90 robot

- The **skew-symmetric matrix** associated to a vector $p = (x, y, z)^T$ is:

$$p^\times := \begin{pmatrix} 0 & -z & y \\ z & 0 & -x \\ -y & x & 0 \end{pmatrix}$$

- The set of skew-symmetric matrix with the brackett $[M_1, M_2] = M_1M_2 - M_2M_1$ is called $SO(3)$ and forms an algebra
- Skew-symmetric matrices and cross product:

$$v^\times u = v \times u$$

- Skew-symmetric matrices and rotations



PRODUCTS AND ASSOCIATED TOOLS

Robotics

- The **scalar product** $\langle v_1, v_2 \rangle$ is defined by: $\langle v_1, v_2 \rangle := v_1^T v_2 \in \mathbb{R}$
- The **cross product** $v_1 \times v_2$ is defined by:

$$v_1 \times v_2 := \begin{pmatrix} v_{1y}v_{2z} - v_{1z}v_{2y} \\ v_{1z}v_{2x} - v_{1x}v_{2z} \\ v_{1x}v_{2y} - v_{1y}v_{2x} \end{pmatrix} \in \mathbb{R}^3$$

N. Marchand

Introduction

Outline

Mechanics

Kinematics

Arm robots
 Inner-loop
 Geometrical model
 Kinematic model
 Dynamical model
 Conclusion

Path planning

Workspace and obstacles
 path planning

Mobile robotics

Visual servoing

RX90 robot

- The **skew-symmetric matrix** associated to a vector $p = (x, y, z)^T$ is:

$$p^\times := \begin{pmatrix} 0 & -z & y \\ z & 0 & -x \\ -y & x & 0 \end{pmatrix}$$

- The set of skew-symmetric matrix with the brackett $[M_1, M_2] = M_1M_2 - M_2M_1$ is called $SO(3)$ and forms an algebra
- Skew-symmetric matrices and cross product:

$$v^\times u = v \times u$$

- Skew-symmetric matrices and rotations

$u^\times \sin \theta + (I - uu^T) \cos \theta + uu^T$ and $\exp((u\theta)^\times)$
 is the rotation of angle θ leaving axis u fixed



ATTITUDE REPRESENTATION

Angles



W.R. Hamilton (1805-1865)

Robotics

● Attitude:

N. Marchand

Introduction

Outline

Mechanics

Kinematics

- Arm robots
- Inner-loop
- Geometrical model
- Kinematic model
- Dynamical model
- Conclusion

Path planning

- Workspace and obstacles
- path planning

Mobile robotics

Visual servoing

RX90 robot



ATTITUDE REPRESENTATION

Angles



W.R. Hamilton (1805-1865)

Robotics

- Attitude:

- equivalent of position for angles: what is the orientation of an object w.r.t. the ground ?

N. Marchand

Introduction

Outline

Mechanics

Kinematics

- Arm robots
- Inner-loop
- Geometrical model
- Kinematic model
- Dynamical model
- Conclusion

Path planning

- Workspace and obstacles
- path planning

Mobile robotics

Visual servoing

RX90 robot



ATTITUDE REPRESENTATION

Angles



W.R. Hamilton (1805-1865)

Robotics

- Attitude:

- equivalent of position for angles: what is the orientation of an object w.r.t. the ground ?
- gives the **rotation that transforms the reference frame into the body frame**

N. Marchand

Introduction

Outline

Mechanics

Kinematics

- Arm robots
- Inner-loop
- Geometrical model
- Kinematic model
- Dynamical model
- Conclusion

Path planning

- Workspace and obstacles
- path planning

Mobile robotics

Visual servoing

RX90 robot



ATTITUDE REPRESENTATION

Angles



W.R. Hamilton (1805-1865)

Robotics

- Attitude:
 - equivalent of position for angles: what is the orientation of an object w.r.t. the ground ?
 - gives the **rotation that transforms the reference frame into the body frame**
- Many attitude representation

N. Marchand

Introduction

Outline

Mechanics

Kinematics

- Arm robots
- Inner-loop
- Geometrical model
- Kinematic model
- Dynamical model
- Conclusion

Path planning

- Workspace and obstacles
- path planning

Mobile robotics

Visual servoing

RX90 robot



ATTITUDE REPRESENTATION

Angles



W.R. Hamilton (1805-1865)

Robotics

- Attitude:
 - equivalent of position for angles: what is the orientation of an object w.r.t. the ground ?
 - gives the **rotation that transforms the reference frame into the body frame**
- Many attitude representation
 - Euler angles

N. Marchand

Introduction

Outline

Mechanics

Kinematics

- Arm robots
- Inner-loop
- Geometrical model
- Kinematic model
- Dynamical model
- Conclusion

Path planning

- Workspace and obstacles
- path planning

Mobile robotics

Visual servoing

RX90 robot



ATTITUDE REPRESENTATION

Angles



W.R. Hamilton (1805-1865)

Robotics

- Attitude:
 - equivalent of position for angles: what is the orientation of an object w.r.t. the ground ?
 - gives the **rotation that transforms the reference frame into the body frame**
- Many attitude representation
 - Euler angles
 - Quaternions

N. Marchand

Introduction

Outline

Mechanics

Kinematics

- Arm robots
- Inner-loop
- Geometrical model
- Kinematic model
- Dynamical model
- Conclusion

Path planning

- Workspace and obstacles
- path planning

Mobile robotics

Visual servoing

RX90 robot



ATTITUDE REPRESENTATION

Angles



W.R. Hamilton (1805-1865)

Robotics

- Attitude:
 - equivalent of position for angles: what is the orientation of an object w.r.t. the ground ?
 - gives the **rotation that transforms the reference frame into the body frame**
- Many attitude representation
 - Euler angles
 - Quaternions
 - Rotation matrix

N. Marchand

Introduction

Outline

Mechanics

Kinematics

Arm robots
 Inner-loop
 Geometrical model
 Kinematic model
 Dynamical model
 Conclusion

Path planning

Workspace and obstacles
 path planning

Mobile robotics

Visual servoing

RX90 robot

ATTITUDE REPRESENTATION

Angles



W.R. Hamilton (1805-1865)

Robotics

- Attitude:
 - equivalent of position for angles: what is the orientation of an object w.r.t. the ground ?
 - gives the **rotation that transforms the reference frame into the body frame**
- Many attitude representation
 - Euler angles
 - Quaternions
 - Rotation matrix
 - Tait-Bryan angles, Fick angles, Helmholtz angles, dip-slip-rake, azimuth-elevation-skew, ...

N. Marchand

Introduction

Outline

Mechanics

Kinematics

- Arm robots
- Inner-loop
- Geometrical model
- Kinematic model
- Dynamical model
- Conclusion

Path planning

- Workspace and obstacles
- path planning

Mobile robotics

Visual servoing

RX90 robot

ATTITUDE REPRESENTATION

Angles



W.R. Hamilton (1805-1865)

Robotics

- Attitude:
 - equivalent of position for angles: what is the orientation of an object w.r.t. the ground ?
 - gives the **rotation that transforms the reference frame into the body frame**
- Many attitude representation
 - Euler angles
 - Quaternions
 - Rotation matrix
 - Tait-Bryan angles, Fick angles, Helmholtz angles, dip-slip-rake, azimuth-elevation-skew, ...

- **Euler angles: 3 angles, 27 possible rotations**

N. Marchand

Introduction

Outline

Mechanics

Kinematics

- Arm robots
- Inner-loop
- Geometrical model
- Kinematic model
- Dynamical model
- Conclusion

Path planning

- Workspace and obstacles
- path planning

Mobile

robotics

Visual

servoing

RX90 robot



ATTITUDE REPRESENTATION

Angles



W.R. Hamilton (1805-1865)

Robotics

- Attitude:
 - equivalent of position for angles: what is the orientation of an object w.r.t. the ground ?
 - gives the **rotation that transforms the reference frame into the body frame**

N. Marchand

Introduction

Outline

Mechanics

- Many attitude representation
 - Euler angles
 - Quaternions
 - Rotation matrix
 - Tait-Bryan angles, Fick angles, Helmholtz angles, dip-slip-rake, azimuth-elevation-skew, ...

Kinematics

- Arm robots
- Inner-loop
- Geometrical model
- Kinematic model
- Dynamical model
- Conclusion

- **Euler angles**: 3 angles, 27 possible rotations
- **Engineering and robotics communities typically use 3-1-3 Euler angles**

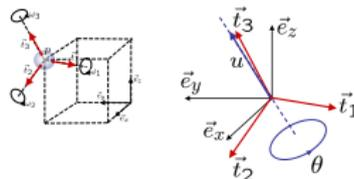

Path planning

- Workspace and obstacles
- path planning

Mobile robotics

Visual servoing

RX90 robot



ATTITUDE REPRESENTATION

Angles



W.R. Hamilton (1805-1865)

Robotics

- Attitude:
 - equivalent of position for angles: what is the orientation of an object w.r.t. the ground ?
 - gives the **rotation that transforms the reference frame into the body frame**

N. Marchand

Introduction

Outline

Mechanics

- Many attitude representation
 - Euler angles
 - Quaternions
 - Rotation matrix
 - Tait-Bryan angles, Fick angles, Helmholtz angles, dip-slip-rake, azimuth-elevation-skew, ...

Kinematics

Arm robots
 Inner-loop
 Geometrical model
 Kinematical model
 Dynamical model
 Conclusion

- **Euler angles**: 3 angles, 27 possible rotations
- Engineering and robotics communities typically use 3-1-3 Euler angles
- **Representations with singularities**

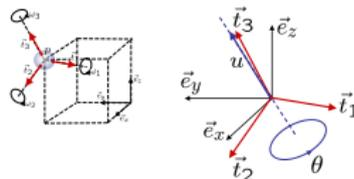

Path planning

Workspace and obstacles
 path planning

Mobile robotics

Visual servoing

RX90 robot



ATTITUDE REPRESENTATION

Angles



W.R. Hamilton (1805-1865)

Robotics

- Attitude:
 - equivalent of position for angles: what is the orientation of an object w.r.t. the ground ?
 - gives the **rotation that transforms the reference frame into the body frame**

N. Marchand

Introduction

Outline

Mechanics

- Many attitude representation
 - Euler angles
 - Quaternions
 - Rotation matrix
 - Tait-Bryan angles, Fick angles, Helmholtz angles, dip-slip-rake, azimuth-elevation-skew, ...

Kinematics

- Arm robots
- Inner-loop
- Geometrical model
- Kinematic model
- Dynamical model
- Conclusion

- **Euler angles**: 3 angles, 27 possible rotations
- Engineering and robotics communities typically use 3-1-3 Euler angles
- Representations with singularities

● Quaternions

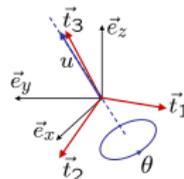
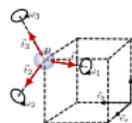

Path planning

- Workspace and obstacles
- path planning

Mobile robotics

Visual servoing

RX90 robot



ATTITUDE REPRESENTATION

Angles



W.R. Hamilton (1805-1865)

Robotics

- Attitude:
 - equivalent of position for angles: what is the orientation of an object w.r.t. the ground ?
 - gives the **rotation that transforms the reference frame into the body frame**

N. Marchand

Introduction

Outline

Mechanics

- Many attitude representation
 - Euler angles
 - Quaternions
 - Rotation matrix
 - Tait-Bryan angles, Fick angles, Helmholtz angles, dip-slip-rake, azimuth-elevation-skew, ...

Kinematics

Arm robots
 Inner-loop
 Geometrical model
 Kinematical model
 Dynamical model
 Conclusion

- **Euler angles**: 3 angles, 27 possible rotations
- Engineering and robotics communities typically use 3-1-3 Euler angles
- Representations with singularities

● Quaternions

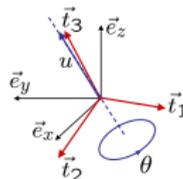
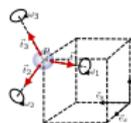

Path planning

Workspace and obstacles
 path planning

Mobile robotics

Visual servoing

RX90 robot

ATTITUDE REPRESENTATION

Angles



W.R. Hamilton (1805-1865)

Robotics

- Attitude:
 - equivalent of position for angles: what is the orientation of an object w.r.t. the ground ?
 - gives the **rotation that transforms the reference frame into the body frame**

N. Marchand

Introduction

Outline

Mechanics

- Many attitude representation
 - Euler angles
 - Quaternions
 - Rotation matrix
 - Tait-Bryan angles, Fick angles, Helmholtz angles, dip-slip-rake, azimuth-elevation-skew, ...

Kinematics

- **Euler angles**: 3 angles, 27 possible rotations
- Engineering and robotics communities typically use 3-1-3 Euler angles
- Representations with singularities

● **Quaternions**

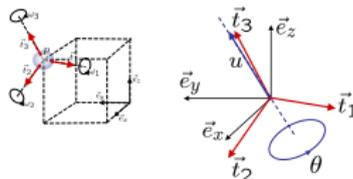

- u fixed by rotation of angle θ

- Arm robots
- Inner-loop
- Geometrical model
- Kinematical model
- Dynamical model
- Conclusion

Path planning

- Workspace and obstacles
- path planning

Mobile robotics

Visual servoing

RX90 robot

ATTITUDE REPRESENTATION

Angles



W.R. Hamilton (1805-1865)

Robotics

- Attitude:
 - equivalent of position for angles: what is the orientation of an object w.r.t. the ground ?
 - gives the **rotation that transforms the reference frame into the body frame**

N. Marchand

Introduction

Outline

Mechanics

- Many attitude representation
 - Euler angles
 - Quaternions
 - Rotation matrix
 - Tait-Bryan angles, Fick angles, Helmholtz angles, dip-slip-rake, azimuth-elevation-skew, ...

Kinematics

- **Euler angles:** 3 angles, 27 possible rotations
- Engineering and robotics communities typically use 3-1-3 Euler angles
- Representations with singularities

● Quaternions

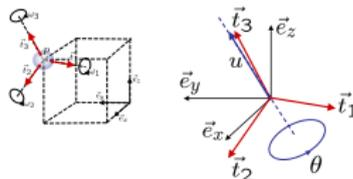

- u fixed by rotation of angle θ
- the quaternion is:

$$q = \begin{pmatrix} u_x \sin \theta/2 \\ u_y \sin \theta/2 \\ u_z \sin \theta/2 \\ \cos \theta/2 \end{pmatrix} = \begin{pmatrix} \vec{q} \\ q_0 \end{pmatrix}$$

- Arm robots
- Inner-loop
- Geometrical model
- Kinematical model
- Dynamical model
- Conclusion

Path planning

- Workspace and obstacles
- path planning

Mobile robotics

Visual servoing

RX90 robot



ATTITUDE REPRESENTATION

Angular velocities

- The angular velocity $\omega = (\omega_1, \omega_2, \omega_3)^T$ represents the rotation speed w.r.t. each axis of the body frame

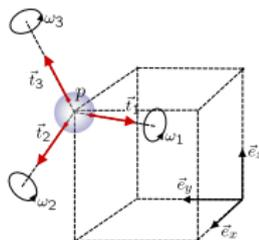

Robotics

N. Marchand

Introduction

Outline

Mechanics

Kinematics

Arm robots

Inner-loop

Geometrical
model

Kinematic model

Dynamical
model

Conclusion

Path planning

Workspace and
obstacles

path planning

Mobile
roboticsVisual
servoing

RX90 robot



ATTITUDE REPRESENTATION

Angular velocities

- The angular velocity $\omega = (\omega_1, \omega_2, \omega_3)^T$ represents the rotation speed w.r.t. each axis of the body frame

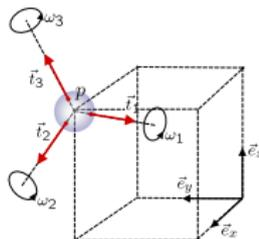

- Caution:** *Angular velocities are not the time derivatives of Euler angles*

Robotics

N. Marchand

Introduction

Outline

Mechanics

Kinematics

Arm robots

Inner-loop

Geometrical
model

Kinematic model

Dynamical
model

Conclusion

Path planning

Workspace and
obstacles

path planning

Mobile
roboticsVisual
servoing

RX90 robot



ATTITUDE REPRESENTATION

Angular velocities

- The angular velocity $\omega = (\omega_1, \omega_2, \omega_3)^T$ represents the rotation speed w.r.t. each axis of the body frame

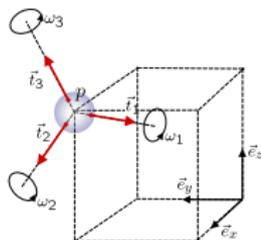

- **Caution:** *Angular velocities are not the time derivatives of Euler angles*
- Angular velocities are given by:

Robotics

N. Marchand

Introduction

Outline

Mechanics

Kinematics

Arm robots

Inner-loop

Geometrical
model

Kinematic model

Dynamical
model

Conclusion

Path planning

Workspace and
obstacles

path planning

Mobile
roboticsVisual
servoing

RX90 robot



ATTITUDE REPRESENTATION

Angular velocities

- The angular velocity $\omega = (\omega_1, \omega_2, \omega_3)^T$ represents the rotation speed w.r.t. each axis of the body frame

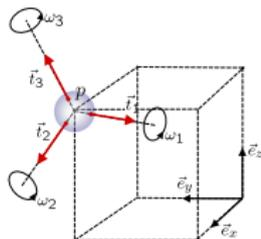

- Caution:** *Angular velocities are not the time derivatives of Euler angles*
- Angular velocities are given by:

- Rotation matrix:

$$\dot{R} = R\omega^\times$$

Robotics

N. Marchand

Introduction

Outline

Mechanics

Kinematics

Arm robots

Inner-loop

Geometrical
model

Kinematic model

Dynamical
model

Conclusion

Path planning

Workspace and
obstacles
path planningMobile
roboticsVisual
servoing

RX90 robot



ATTITUDE REPRESENTATION

Angular velocities

- The angular velocity $\omega = (\omega_1, \omega_2, \omega_3)^T$ represents the rotation speed w.r.t. each axis of the body frame

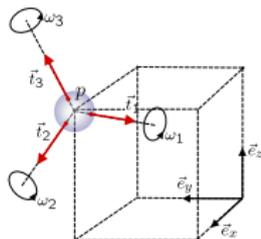

- Caution:** Angular velocities are not the time derivatives of Euler angles
- Angular velocities are given by:

- Rotation matrix:

$$\dot{R} = R\omega^x$$

- Quaternions :

$$\begin{aligned} \dot{q} &= \frac{1}{2} \Omega(\vec{\omega}) q \\ &= \frac{1}{2} \Xi(q) \vec{\omega} \end{aligned} \quad \text{with} \quad \begin{cases} \Omega(\vec{\omega}) = \begin{pmatrix} 0 & -\vec{\omega}^T \\ \vec{\omega} & -\vec{\omega}^x \end{pmatrix} \\ \Xi(q) = \begin{pmatrix} -\vec{q}^T \\ I_{3 \times 3} q_0 + \vec{q}^x \end{pmatrix} \end{cases}$$



MOVING FRAMES



P. Varignon (1654-1722)

Robotics

N. Marchand

Introduction

Outline

Mechanics

Kinematics

- Arm robots
- Inner-loop
- Geometrical model
- Kinematic model
- Dynamical model
- Conclusion

Path planning

- Workspace and obstacles
- path planning

Mobile robotics

Visual servoing

RX90 robot

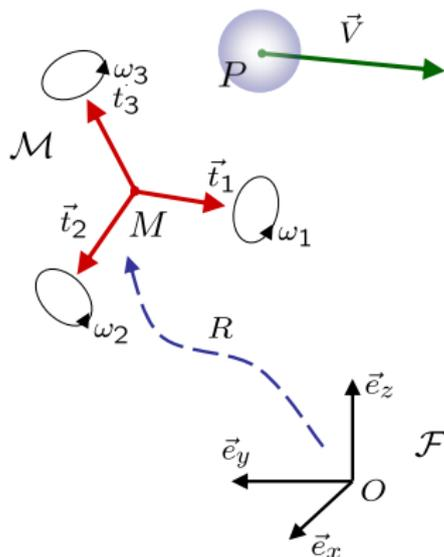

Varignon's formula

$$\frac{d\vec{U}^{\mathcal{M}}}{dt} = \frac{d\vec{U}^{\mathcal{F}}}{dt} + \Omega^{\mathcal{F}/\mathcal{M}} \times \vec{U}^{\mathcal{F}}$$



MOVING FRAMES

Robotics

- $\mathcal{F} := (O, \vec{e}_x, \vec{e}_y, \vec{e}_z)$ fixed frame

N. Marchand

Introduction

Outline

Mechanics

Kinematics

- Arm robots
- Inner-loop
- Geometrical model
- Kinematic model
- Dynamical model
- Conclusion

Path planning

- Workspace and obstacles
- path planning

Mobile robotics

Visual servoing

RX90 robot

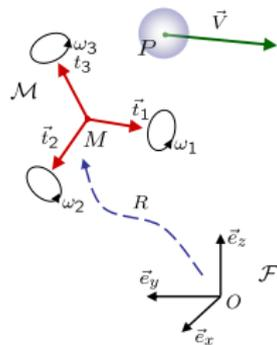



MOVING FRAMES

Robotics

N. Marchand

Introduction

Outline

Mechanics

Kinematics

- Arm robots
- Inner-loop
- Geometrical model
- Kinematic model
- Dynamical model
- Conclusion

Path planning

- Workspace and obstacles
- path planning

Mobile robotics

Visual servoing

RX90 robot

- $\mathcal{F} := (O, \vec{e}_x, \vec{e}_y, \vec{e}_z)$ fixed frame
- $\mathcal{M} := (M, \vec{t}_1, \vec{t}_2, \vec{t}_3)$: mobile frame

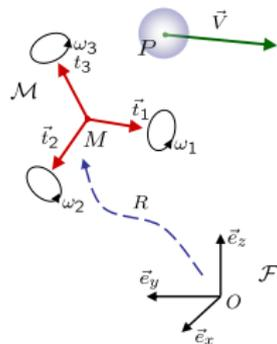



MOVING FRAMES

Robotics

N. Marchand

Introduction

Outline

Mechanics

Kinematics

Arm robots
Inner-loop
Geometrical
model
Kinematic model
Dynamical
model
Conclusion

Path planning

Workspace and
obstacles
path planning

Mobile
robotics

Visual
servoing

RX90 robot

- $\mathcal{F} := (O, \vec{e}_x, \vec{e}_y, \vec{e}_z)$ fixed frame
- $\mathcal{M} := (M, \vec{t}_1, \vec{t}_2, \vec{t}_3)$: mobile frame
- R : rotation matrix s.t. $\mathcal{M} = R\mathcal{F}$

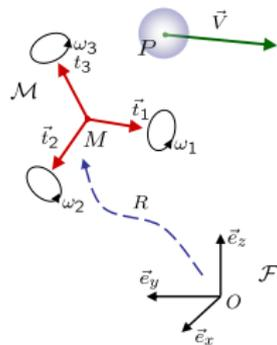



MOVING FRAMES

Robotics

N. Marchand

Introduction

Outline

Mechanics

Kinematics

- Arm robots
- Inner-loop
- Geometrical model
- Kinematic model
- Dynamical model
- Conclusion

Path planning

- Workspace and obstacles
- path planning

Mobile robotics

Visual servoing

RX90 robot

- $\mathcal{F} := (O, \vec{e}_x, \vec{e}_y, \vec{e}_z)$ fixed frame
- $\mathcal{M} := (M, \vec{t}_1, \vec{t}_2, \vec{t}_3)$: mobile frame
- R : rotation matrix s.t. $\mathcal{M} = R\mathcal{F}$
- $\Omega^{\mathcal{M}/\mathcal{F}}$: angular velocity matrix of \mathcal{M} w.r

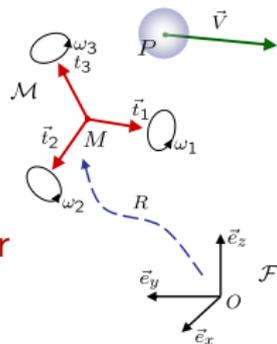



MOVING FRAMES

Robotics

N. Marchand

Introduction

Outline

Mechanics

Kinematics

Arm robots
Inner-loop
Geometrical model
Kinematic model
Dynamical model
Conclusion

Path planning

Workspace and obstacles
path planning

Mobile robotics

Visual servoing

RX90 robot

- $\mathcal{F} := (O, \vec{e}_x, \vec{e}_y, \vec{e}_z)$ fixed frame
- $\mathcal{M} := (M, \vec{t}_1, \vec{t}_2, \vec{t}_3)$: mobile frame
- R : rotation matrix s.t. $\mathcal{M} = R\mathcal{F}$
- $\Omega^{\mathcal{M}/\mathcal{F}}$: angular velocity matrix of \mathcal{M} w.r
- **Velocities:**

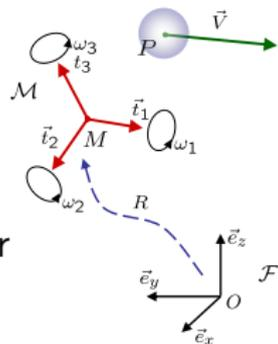

$$\frac{d\vec{OP}^{\mathcal{F}}}{dt} = \frac{d\vec{OM}^{\mathcal{F}}}{dt} + \frac{d\vec{MP}^{\mathcal{M}}}{dt} + \Omega^{\mathcal{M}/\mathcal{F}} \times \vec{MP}$$



MOVING FRAMES

Robotics

N. Marchand

Introduction

Outline

Mechanics

Kinematics

Arm robots
 Inner-loop
 Geometrical model
 Kinematic model
 Dynamical model
 Conclusion

Path planning

Workspace and obstacles
 path planning

Mobile robotics

Visual servoing

RX90 robot

- $\mathcal{F} := (O, \vec{e}_x, \vec{e}_y, \vec{e}_z)$ fixed frame
- $\mathcal{M} := (M, \vec{t}_1, \vec{t}_2, \vec{t}_3)$: mobile frame
- R : rotation matrix s.t. $\mathcal{M} = R\mathcal{F}$
- $\Omega^{\mathcal{M}/\mathcal{F}}$: angular velocity matrix of \mathcal{M} w.r
- **Velocities:**

- Absolute velocity

$$\frac{d\vec{OP}^{\mathcal{F}}}{dt} = \frac{d\vec{OM}^{\mathcal{F}}}{dt} + \frac{d\vec{MP}^{\mathcal{M}}}{dt} + \Omega^{\mathcal{M}/\mathcal{F}} \times \vec{MP}$$

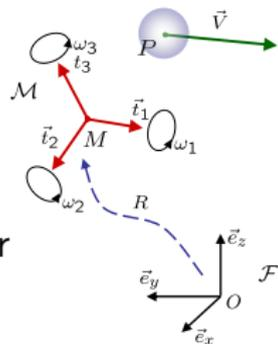

MOVING FRAMES

Robotics

- $\mathcal{F} := (O, \vec{e}_x, \vec{e}_y, \vec{e}_z)$ fixed frame
- $\mathcal{M} := (M, \vec{t}_1, \vec{t}_2, \vec{t}_3)$: mobile frame
- R : rotation matrix s.t. $\mathcal{M} = R\mathcal{F}$
- $\Omega^{\mathcal{M}/\mathcal{F}}$: angular velocity matrix of \mathcal{M} w.r
- **Velocities:**

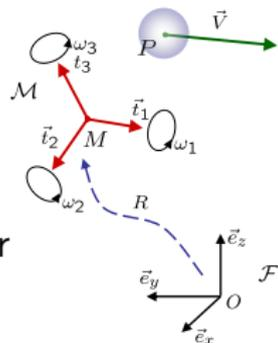

- Absolute velocity

$$\frac{d\vec{OP}^{\mathcal{F}}}{dt} = \frac{d\vec{OM}^{\mathcal{F}}}{dt} + \frac{d\vec{MP}^{\mathcal{M}}}{dt} + \Omega^{\mathcal{M}/\mathcal{F}} \times \vec{MP}$$

- Speed of \mathcal{M} w.r.t \mathcal{F}

Introduction

Outline

Mechanics

Kinematics

Arm robots

Inner-loop

Geometrical model

Kinematic model

Dynamical model

Conclusion

Path planning

Workspace and obstacles

path planning

Mobile robotics

Visual servoing

RX90 robot

MOVING FRAMES

- $\mathcal{F} := (O, \vec{e}_x, \vec{e}_y, \vec{e}_z)$ fixed frame
- $\mathcal{M} := (M, \vec{t}_1, \vec{t}_2, \vec{t}_3)$: mobile frame
- R : rotation matrix s.t. $\mathcal{M} = R\mathcal{F}$
- $\Omega^{M/\mathcal{F}}$: angular velocity matrix of \mathcal{M} w.r
- **Velocities:**

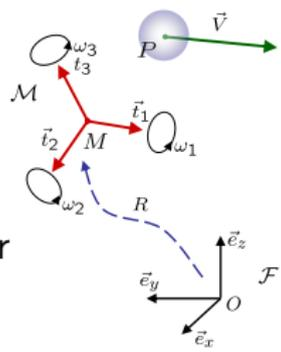

- Absolute velocity

$$\frac{d\vec{OP}^{\mathcal{F}}}{dt} = \frac{d\vec{OM}^{\mathcal{F}}}{dt} + \frac{d\vec{MP}^{\mathcal{M}}}{dt} + \Omega^{M/\mathcal{F}} \times \vec{MP}$$

- Speed of \mathcal{M} w.r.t \mathcal{F}
- Relative velocity



MOVING FRAMES

Robotics

N. Marchand

Introduction

Outline

Mechanics

Kinematics

Arm robots
Inner-loop
Geometrical
model
Kinematic model
Dynamical
model
Conclusion

Path planning

Workspace and
obstacles
path planning

Mobile
robotics

Visual
servoing

RX90 robot

- $\mathcal{F} := (O, \vec{e}_x, \vec{e}_y, \vec{e}_z)$ fixed frame
- $\mathcal{M} := (M, \vec{t}_1, \vec{t}_2, \vec{t}_3)$: mobile frame
- R : rotation matrix s.t. $\mathcal{M} = R\mathcal{F}$
- $\Omega^{M/\mathcal{F}}$: angular velocity matrix of \mathcal{M} w.r
- **Velocities:**

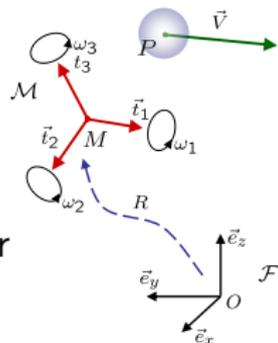

- Absolute velocity

$$\frac{d\vec{OP}^{\mathcal{F}}}{dt} = \frac{d\vec{OM}^{\mathcal{F}}}{dt} + \frac{d\vec{MP}^{\mathcal{M}}}{dt} + \Omega^{M/\mathcal{F}} \times \vec{MP}$$

- Speed of \mathcal{M} w.r.t \mathcal{F}
- Relative velocity
- Due to the rotation of \mathcal{M} w.r.t. \mathcal{F}



MOVING FRAMES

- $\mathcal{F} := (O, \vec{e}_x, \vec{e}_y, \vec{e}_z)$ fixed frame

Robotics

N. Marchand

Introduction

Outline

Mechanics

Kinematics

- Arm robots
- Inner-loop
- Geometrical model
- Kinematic model
- Dynamical model
- Conclusion

Path planning

- Workspace and obstacles
- path planning

Mobile robotics

Visual servoing

RX90 robot

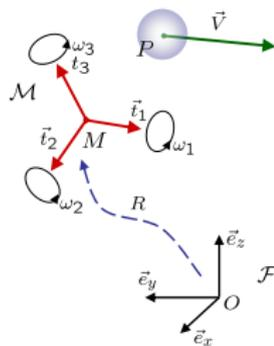



MOVING FRAMES

- $\mathcal{F} := (O, \vec{e}_x, \vec{e}_y, \vec{e}_z)$ fixed frame
- $\mathcal{M} := (M, \vec{t}_1, \vec{t}_2, \vec{t}_3)$: mobile frame

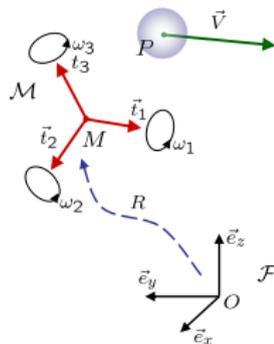

Robotics

N. Marchand

Introduction

Outline

Mechanics

Kinematics

- Arm robots
- Inner-loop
- Geometrical model
- Kinematic model
- Dynamical model
- Conclusion

Path planning

- Workspace and obstacles
- path planning

Mobile robotics

Visual servoing

RX90 robot



MOVING FRAMES

- $\mathcal{F} := (O, \vec{e}_x, \vec{e}_y, \vec{e}_z)$ fixed frame
- $\mathcal{M} := (M, \vec{t}_1, \vec{t}_2, \vec{t}_3)$: mobile frame
- R : rotation matrix s.t. $\mathcal{M} = R\mathcal{F}$

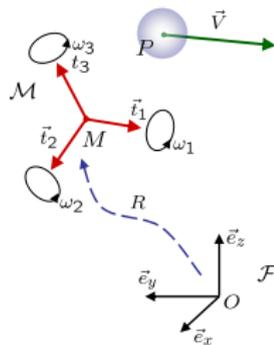

Robotics

N. Marchand

Introduction

Outline

Mechanics

Kinematics

- Arm robots
- Inner-loop
- Geometrical model
- Kinematic model
- Dynamical model
- Conclusion

Path planning

- Workspace and obstacles
- path planning

Mobile robotics

Visual servoing

RX90 robot



MOVING FRAMES

- $\mathcal{F} := (O, \vec{e}_x, \vec{e}_y, \vec{e}_z)$ fixed frame
- $\mathcal{M} := (M, \vec{t}_1, \vec{t}_2, \vec{t}_3)$: mobile frame
- R : rotation matrix s.t. $\mathcal{M} = R\mathcal{F}$
- $\Omega^{\mathcal{M}/\mathcal{F}}$: angular velocity matrix of \mathcal{M} w.r.t. \mathcal{F}

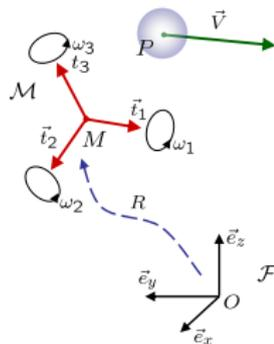

Robotics

N. Marchand

Introduction

Outline

Mechanics

Kinematics

- Arm robots
- Inner-loop
- Geometrical model
- Kinematic model
- Dynamical model
- Conclusion

Path planning

- Workspace and obstacles
- path planning

Mobile robotics

Visual servoing

RX90 robot



MOVING FRAMES

- $\mathcal{F} := (O, \vec{e}_x, \vec{e}_y, \vec{e}_z)$ fixed frame
- $\mathcal{M} := (M, \vec{t}_1, \vec{t}_2, \vec{t}_3)$: mobile frame
- R : rotation matrix s.t. $\mathcal{M} = R\mathcal{F}$
- $\Omega^{\mathcal{M}/\mathcal{F}}$: angular velocity matrix of \mathcal{M} w.r.t. \mathcal{F}
- **Acceleration:**

$$\ddot{p}^{\mathcal{F}} := \frac{d\dot{p}^{\mathcal{F}\mathcal{F}}}{dt} = \frac{d\dot{p}^{\mathcal{M}\mathcal{F}}}{dt} + \frac{d\Omega^{\mathcal{M}/\mathcal{F}} \times p^{\mathcal{F}}}{dt}$$

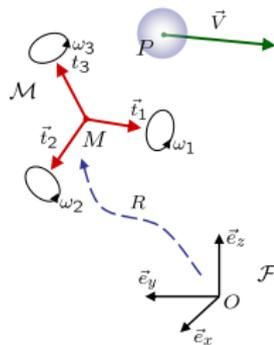

Robotics

N. Marchand

Introduction

Outline

Mechanics

Kinematics

Arm robots

Inner-loop

Geometrical
model

Kinematic model

Dynamical
model

Conclusion

Path planning

Workspace and
obstacles

path planning

Mobile
roboticsVisual
servoing

RX90 robot



MOVING FRAMES

- $\mathcal{F} := (O, \vec{e}_x, \vec{e}_y, \vec{e}_z)$ fixed frame
- $\mathcal{M} := (M, \vec{t}_1, \vec{t}_2, \vec{t}_3)$: mobile frame
- R : rotation matrix s.t. $\mathcal{M} = R\mathcal{F}$
- $\Omega^{\mathcal{M}/\mathcal{F}}$: angular velocity matrix of \mathcal{M} w.r.t. \mathcal{F}
- **Acceleration:**

$$\ddot{P}^{\mathcal{F}} := \frac{d\dot{P}^{\mathcal{F}\mathcal{F}}}{dt} = \frac{d\dot{P}^{\mathcal{M}\mathcal{F}}}{dt} + \frac{d\Omega^{\mathcal{M}/\mathcal{F}} \times P^{\mathcal{F}}}{dt}$$

- $\frac{d\dot{P}^{\mathcal{M}\mathcal{F}}}{dt} = \ddot{P}^{\mathcal{M}} + \Omega^{\mathcal{M}/\mathcal{F}} \times \dot{P}^{\mathcal{M}}$ (Varignon's formula)

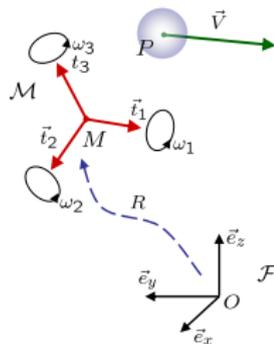

Robotics

N. Marchand

Introduction

Outline

Mechanics

Kinematics

Arm robots

Inner-loop

Geometrical
model

Kinematic model

Dynamical
model

Conclusion

Path planning

Workspace and
obstacles

path planning

Mobile

robotics

Visual

servoing

RX90 robot



MOVING FRAMES

- $\mathcal{F} := (O, \vec{e}_x, \vec{e}_y, \vec{e}_z)$ fixed frame
- $\mathcal{M} := (M, \vec{t}_1, \vec{t}_2, \vec{t}_3)$: mobile frame
- R : rotation matrix s.t. $\mathcal{M} = R\mathcal{F}$
- $\Omega^{\mathcal{M}/\mathcal{F}}$: angular velocity matrix of \mathcal{M} w.r.t. \mathcal{F}
- **Acceleration:**

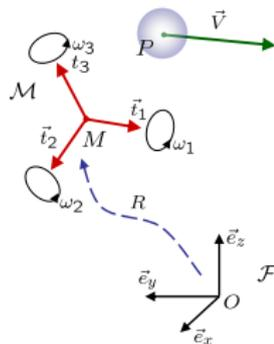

$$\ddot{P}^{\mathcal{F}} := \frac{d\dot{P}^{\mathcal{F}\mathcal{F}}}{dt} = \frac{d\dot{P}^{\mathcal{M}\mathcal{F}}}{dt} + \frac{d\Omega^{\mathcal{M}/\mathcal{F}} \times P^{\mathcal{F}}}{dt}$$

- $\frac{d\dot{P}^{\mathcal{M}\mathcal{F}}}{dt} = \ddot{P}^{\mathcal{M}} + \Omega^{\mathcal{M}/\mathcal{F}} \times \dot{P}^{\mathcal{M}}$ (Varignon's formula)
- $\frac{d\Omega^{\mathcal{M}/\mathcal{F}} \times P^{\mathcal{F}}}{dt} = \dot{\Omega}^{\mathcal{M}/\mathcal{F}} \times P^{\mathcal{F}} + \Omega^{\mathcal{M}/\mathcal{F}} \times \dot{P}^{\mathcal{F}} =$
 $\dot{\Omega}^{\mathcal{M}/\mathcal{F}} \times P^{\mathcal{F}} + \Omega^{\mathcal{M}/\mathcal{F}} \times \dot{P}^{\mathcal{M}} + \Omega^{\mathcal{M}/\mathcal{F}} \times (\Omega^{\mathcal{M}/\mathcal{F}} \times P^{\mathcal{F}})$

all together:

$$\ddot{P}^{\mathcal{M}} = \ddot{P}^{\mathcal{F}} - \mathbf{2\Omega} \times \dot{P}^{\mathcal{M}} - \mathbf{\dot{\Omega}} \times P^{\mathcal{F}} - \mathbf{\Omega} \times (\mathbf{\Omega} \times P^{\mathcal{F}})$$

Robotics

N. Marchand

Introduction

Outline

Mechanics

Kinematics

Arm robots

Inner-loop

Geometrical
model

Kinematic model

Dynamical
model

Conclusion

Path planning

Workspace and
obstacles

path planning

Mobile
roboticsVisual
servoing

RX90 robot



MOVING FRAMES

- $\mathcal{F} := (O, \vec{e}_x, \vec{e}_y, \vec{e}_z)$ fixed frame
- $\mathcal{M} := (M, \vec{t}_1, \vec{t}_2, \vec{t}_3)$: mobile frame
- R : rotation matrix s.t. $\mathcal{M} = R\mathcal{F}$
- $\Omega^{\mathcal{M}/\mathcal{F}}$: angular velocity matrix of \mathcal{M} w.r.t. \mathcal{F}
- **Acceleration:**

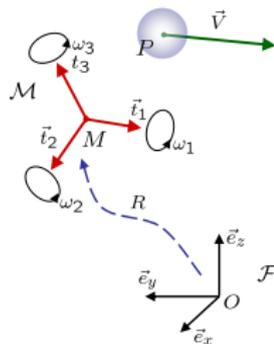

$$\ddot{p}^{\mathcal{F}} := \frac{d\dot{p}^{\mathcal{F}}}{dt} = \frac{d\dot{p}^{\mathcal{M}}}{dt} + \frac{d\Omega^{\mathcal{M}/\mathcal{F}} \times p^{\mathcal{F}}}{dt}$$

- $\frac{d\dot{p}^{\mathcal{M}}}{dt} = \ddot{p}^{\mathcal{M}} + \Omega^{\mathcal{M}/\mathcal{F}} \times \dot{p}^{\mathcal{M}}$ (Varignon's formula)
- $\frac{d\Omega^{\mathcal{M}/\mathcal{F}} \times p^{\mathcal{F}}}{dt} = \dot{\Omega}^{\mathcal{M}/\mathcal{F}} \times p^{\mathcal{F}} + \Omega^{\mathcal{M}/\mathcal{F}} \times \dot{p}^{\mathcal{F}} =$
 $\dot{\Omega}^{\mathcal{M}/\mathcal{F}} \times p^{\mathcal{F}} + \Omega^{\mathcal{M}/\mathcal{F}} \times \dot{p}^{\mathcal{M}} + \Omega^{\mathcal{M}/\mathcal{F}} \times (\Omega^{\mathcal{M}/\mathcal{F}} \times p^{\mathcal{F}})$

all together:

$$\ddot{p}^{\mathcal{M}} = \ddot{p}^{\mathcal{F}} - \underbrace{2\Omega \times \dot{p}^{\mathcal{M}}}_{\text{Coriolis effect}} - \underbrace{\dot{\Omega} \times p^{\mathcal{F}}}_{\text{Euler acceleration}} - \underbrace{\Omega \times (\Omega \times p^{\mathcal{F}})}_{\text{Centrifugal acceleration}}$$

- Coriolis effect



MOVING FRAMES

- $\mathcal{F} := (O, \vec{e}_x, \vec{e}_y, \vec{e}_z)$ fixed frame
- $\mathcal{M} := (M, \vec{t}_1, \vec{t}_2, \vec{t}_3)$: mobile frame
- R : rotation matrix s.t. $\mathcal{M} = R\mathcal{F}$
- $\Omega^{\mathcal{M}/\mathcal{F}}$: angular velocity matrix of \mathcal{M} w.r.t. \mathcal{F}
- **Acceleration:**

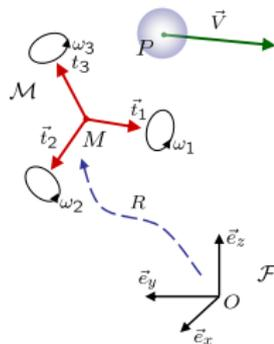

$$\ddot{P}^{\mathcal{F}} := \frac{d\dot{P}^{\mathcal{F}}}{dt} = \frac{d\dot{P}^{\mathcal{M}}}{dt} + \frac{d\Omega^{\mathcal{M}/\mathcal{F}} \times P^{\mathcal{F}}}{dt}$$

- $\frac{d\dot{P}^{\mathcal{M}}}{dt} = \ddot{P}^{\mathcal{M}} + \Omega^{\mathcal{M}/\mathcal{F}} \times \dot{P}^{\mathcal{M}}$ (Varignon's formula)
- $\frac{d\Omega^{\mathcal{M}/\mathcal{F}} \times P^{\mathcal{F}}}{dt} = \dot{\Omega}^{\mathcal{M}/\mathcal{F}} \times P^{\mathcal{F}} + \Omega^{\mathcal{M}/\mathcal{F}} \times \dot{P}^{\mathcal{F}} =$
 $\dot{\Omega}^{\mathcal{M}/\mathcal{F}} \times P^{\mathcal{F}} + \Omega^{\mathcal{M}/\mathcal{F}} \times \dot{P}^{\mathcal{M}} + \Omega^{\mathcal{M}/\mathcal{F}} \times (\Omega^{\mathcal{M}/\mathcal{F}} \times P^{\mathcal{F}})$

all together:

$$\ddot{P}^{\mathcal{M}} = \ddot{P}^{\mathcal{F}} - \underbrace{2\Omega \times \dot{P}^{\mathcal{M}}}_{\text{Coriolis effect}} - \underbrace{\dot{\Omega} \times P^{\mathcal{F}}}_{\text{Euler effect (tangential acceleration)}} - \underbrace{\Omega \times (\Omega \times P^{\mathcal{F}})}_{\text{Centrifugal effect}}$$

- Coriolis effect
- Euler effect (tangential acceleration)



MOVING FRAMES

- $\mathcal{F} := (O, \vec{e}_x, \vec{e}_y, \vec{e}_z)$ fixed frame
- $\mathcal{M} := (M, \vec{t}_1, \vec{t}_2, \vec{t}_3)$: mobile frame
- R : rotation matrix s.t. $\mathcal{M} = R\mathcal{F}$
- $\Omega^{\mathcal{M}/\mathcal{F}}$: angular velocity matrix of \mathcal{M} w.r.t. \mathcal{F}
- **Acceleration:**

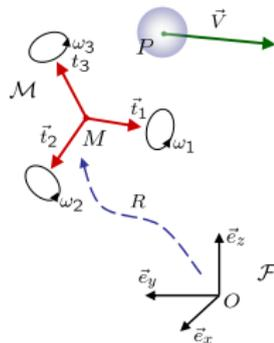

$$\ddot{P}^{\mathcal{F}} := \frac{d\dot{P}^{\mathcal{F}}}{dt} = \frac{d\dot{P}^{\mathcal{M}}}{dt} + \frac{d\Omega^{\mathcal{M}/\mathcal{F}} \times P^{\mathcal{F}}}{dt}$$

- $\frac{d\dot{P}^{\mathcal{M}}}{dt} = \ddot{P}^{\mathcal{M}} + \Omega^{\mathcal{M}/\mathcal{F}} \times \dot{P}^{\mathcal{M}}$ (Varignon's formula)
- $\frac{d\Omega^{\mathcal{M}/\mathcal{F}} \times P^{\mathcal{F}}}{dt} = \dot{\Omega}^{\mathcal{M}/\mathcal{F}} \times P^{\mathcal{F}} + \Omega^{\mathcal{M}/\mathcal{F}} \times \dot{P}^{\mathcal{F}} =$
 $\dot{\Omega}^{\mathcal{M}/\mathcal{F}} \times P^{\mathcal{F}} + \Omega^{\mathcal{M}/\mathcal{F}} \times \dot{P}^{\mathcal{M}} + \Omega^{\mathcal{M}/\mathcal{F}} \times (\Omega^{\mathcal{M}/\mathcal{F}} \times P^{\mathcal{F}})$

all together:

$$\ddot{P}^{\mathcal{M}} = \ddot{P}^{\mathcal{F}} - \boxed{2\Omega \times \dot{P}^{\mathcal{M}}} - \boxed{\dot{\Omega} \times P^{\mathcal{F}}} - \boxed{\Omega \times (\Omega \times P^{\mathcal{F}})}$$

- Coriolis effect
- Euler effect (tangent acceleration)
- Centrifugal effect

FORCES AND TORQUES

Robotics

- A force ... everybody knows what it is:
a vector, denoted \vec{F}

N. Marchand

Introduction

Outline

Mechanics

Kinematics

Arm robots

Inner-loop

Geometrical
model

Kinematic model

Dynamical
model

Conclusion

Path planning

Workspace and
obstacles

path planning

Mobile
robotics

Visual
servoing

RX90 robot

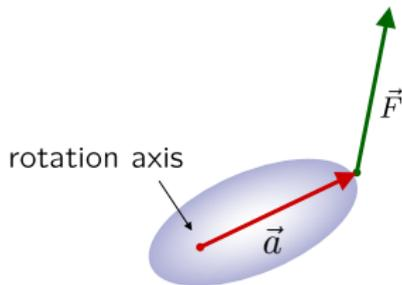

FORCES AND TORQUES

Robotics

N. Marchand

Introduction

Outline

Mechanics

Kinematics

Arm robots

Inner-loop

Geometrical
model

Kinematic model

Dynamical
model

Conclusion

Path planning

Workspace and
obstacles

path planning

Mobile
robotics

Visual
servoing

RX90 robot

- A force ... everybody knows what it is:
a vector, denoted \vec{F}

- A torque (moment or moment of force):

$$\vec{\tau} = \vec{p} \times \vec{F}$$

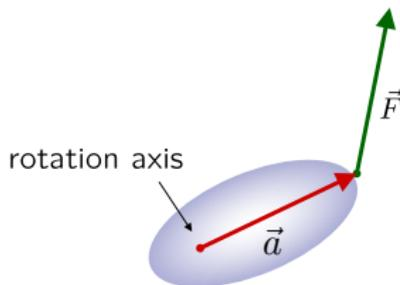



CONSERVATION OF LINEAR MOMENTUM

Linear Momentum

$$P := \sum_i m_i \vec{v}_i \in \mathbb{R}^3$$

where i denotes the index of the element composing the system, m_i it's mass and v_i it's speed (in a fixed frame)

- Single body system:

$$P = M\vec{v}$$

Newton's second law (conservation of the linear momentum)

$$\sum \vec{F} = \frac{dP^{\mathcal{F}}}{dt}$$





CONSERVATION OF ANGULAR MOMENTUM

Robotics

N. Marchand

Introduction

Outline

Mechanics

Kinematics

Arm robots
 Inner-loop
 Geometrical model
 Kinematic model
 Dynamical model
 Conclusion

Path planning

Workspace and obstacles
 path planning

Mobile robotics

Visual servoing

RX90 robot

Angular Momentum

$$L := \vec{p} \times P \in \mathbb{R}^3$$

where \vec{p} denotes the position vector and P the linear momentum

Conservation of the angular momentum

$$\sum \vec{\tau} = \frac{dL^{\mathcal{F}}}{dt}$$

- In a moving frame (Varignon's formula):

$$\frac{dL^{\mathcal{F}}}{dt} = \frac{dL^{\mathcal{M}}}{dt} + \Omega \times L$$





CONSERVATION OF ANGULAR MOMENTUM

Robotics

N. Marchand

Introduction

Outline

Mechanics

Kinematics

Arm robots
Inner-loop
Geometrical
model
Kinematic model
Dynamical
model
Conclusion

Path planning

Workspace and
obstacles
path planning

Mobile
robotics

Visual
servoing

RX90 robot

Inertia momentum

$$dJ = r^2 dm$$

where r is the distance of the elementary mass dm to the rotation axis

One has:

Conservation of the angular momentum

$$\sum \vec{\tau} = J \frac{d\Omega^{\mathcal{F}}}{dt}$$

with $J = \int_{\text{rigid body}} dJ$

- In a moving frame (Varignon's formula):

$$J \frac{d\Omega^{\mathcal{F}}}{dt} = J \frac{d\Omega^{\mathcal{M}}}{dt} + \Omega \times L$$





Example: the X4 helicopter

How it works ?

Robotics

N. Marchand

Introduction

Outline

Mechanics

Kinematics

Arm robots

Inner-loop

Geometrical
model

Kinematic model

Dynamical
model

Conclusion

Path planning

Workspace and
obstacles

path planning

Mobile
robotics

Visual
servoing

RX90 robot

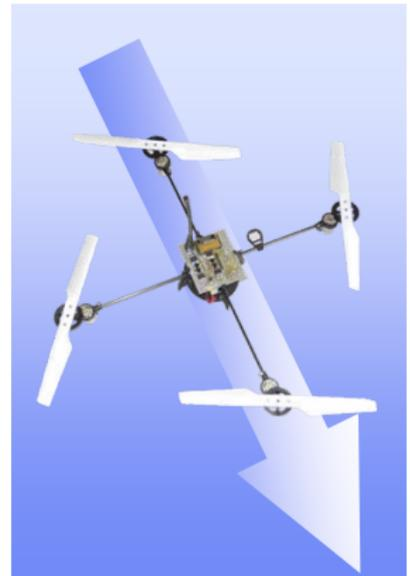



Example: the X4 helicopter

How it works ?

- 4 fixed rotors with controlled rotation speed s_i

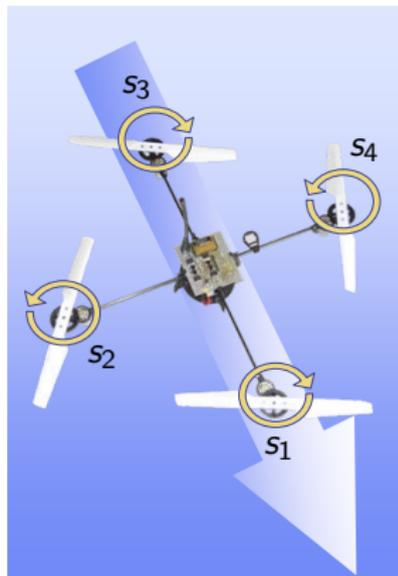

Robotics

N. Marchand

Introduction

Outline

Mechanics

Kinematics

Arm robots

Inner-loop

Geometrical
model

Kinematic model

Dynamical
model

Conclusion

Path planning

Workspace and
obstacles

path planning

Mobile
robotics

Visual
servoing

RX90 robot

Example: the X4 helicopter

How it works ?

- 4 fixed rotors with controlled rotation speed s_i
- 4 generated forces F_i

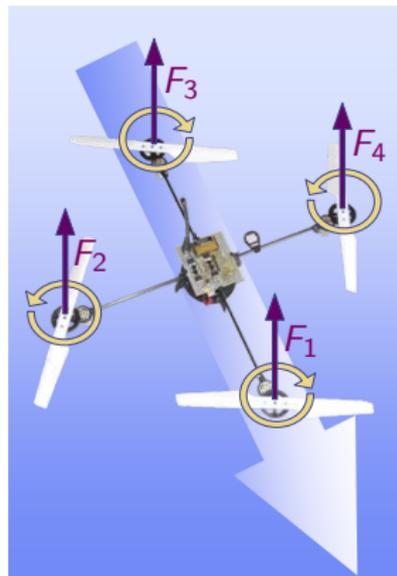

Robotics

N. Marchand

Introduction

Outline

Mechanics

Kinematics

Arm robots

Inner-loop

Geometrical
model

Kinematic model

Dynamical
model

Conclusion

Path planning

Workspace and
obstacles

path planning

Mobile
robotics

Visual
servoing

RX90 robot

Example: the X4 helicopter

How it works ?

- 4 fixed rotors with controlled rotation speed s_i
- 4 generated forces F_i
- 4 counter-rotating torques Γ_i

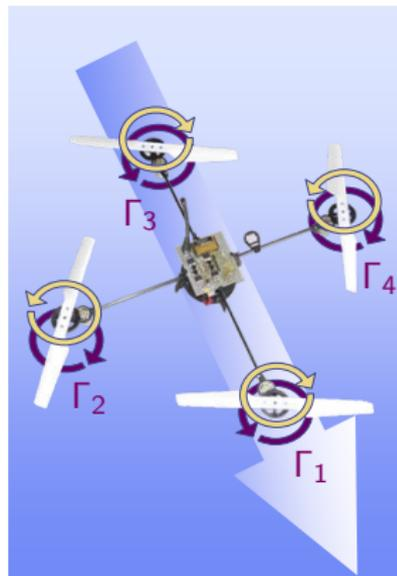

Robotics

N. Marchand

Introduction

Outline

Mechanics

Kinematics

Arm robots

Inner-loop

Geometrical model

Kinematic model

Dynamical model

Conclusion

Path planning

Workspace and obstacles

path planning

Mobile robotics

Visual servoing

RX90 robot

Example: the X4 helicopter

How it works ?

Robotics

N. Marchand

Introduction

Outline

Mechanics

Kinematics

Arm robots

Inner-loop

Geometrical
model

Kinematic model

Dynamical
model

Conclusion

Path planning

Workspace and
obstacles

path planning

Mobile
robotics

Visual
servoing

RX90 robot

- 4 fixed rotors with controlled rotation speed s_i
- 4 generated forces F_i
- 4 counter-rotating torques Γ_i
- **Roll movement**

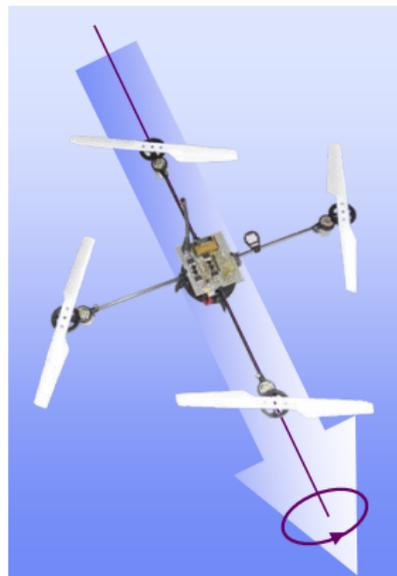

Example: the X4 helicopter

How it works ?

Robotics

N. Marchand

Introduction

Outline

Mechanics

Kinematics

Arm robots

Inner-loop

Geometrical
model

Kinematic model

Dynamical
model

Conclusion

Path planning

Workspace and
obstacles

path planning

Mobile
robotics

Visual
servoing

RX90 robot

- 4 fixed rotors with controlled rotation speed s_i
- 4 generated forces F_i
- 4 counter-rotating torques Γ_i
- **Roll movement** generated with a dissymmetry between left and right forces:

$$\Gamma_r = l(F_4 - F_2)$$

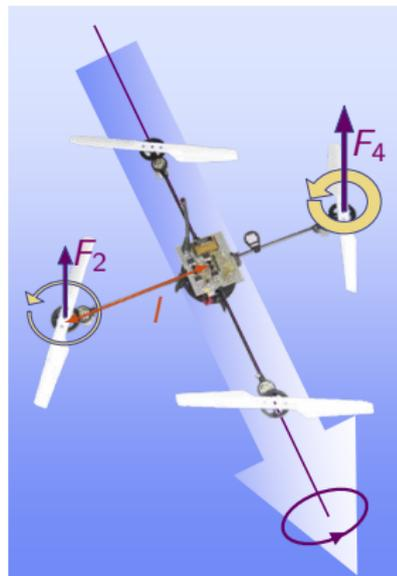

Example: the X4 helicopter

How it works ?

Robotics

N. Marchand

Introduction

Outline

Mechanics

Kinematics

Arm robots

Inner-loop

Geometrical
model

Kinematic model

Dynamical
model

Conclusion

Path planning

Workspace and
obstacles

path planning

Mobile
robotics

Visual
servoing

RX90 robot

- 4 fixed rotors with controlled rotation speed s_i
- 4 generated forces F_i
- 4 counter-rotating torques Γ_i
- **Roll movement** generated with a dissymmetry between left and right forces:

$$\Gamma_r = l(F_4 - F_2)$$

- **Pitch movement**

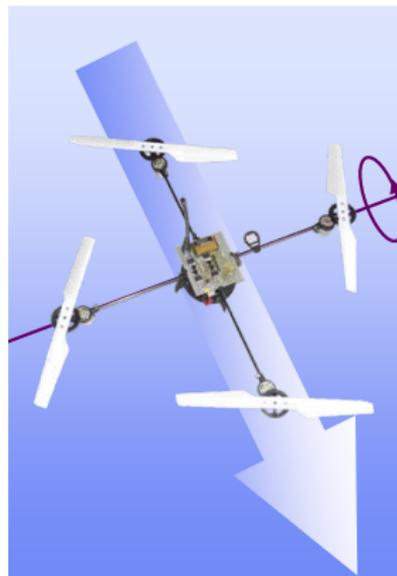

Example: the X4 helicopter

How it works ?

Robotics

N. Marchand

Introduction

Outline

Mechanics

Kinematics

Arm robots

Inner-loop

Geometrical
model

Kinematic model

Dynamical
model

Conclusion

Path planning

Workspace and
obstacles
path planning

Mobile
robotics

Visual
servoing

RX90 robot

- 4 fixed rotors with controlled rotation speed s_i
- 4 generated forces F_i
- 4 counter-rotating torques Γ_i
- **Roll movement** generated with a dissymmetry between left and right forces:

$$\Gamma_r = l(F_4 - F_2)$$

- **Pitch movement** generated with a dissymmetry between front and rear forces:

$$\Gamma_p = l(F_1 - F_3)$$

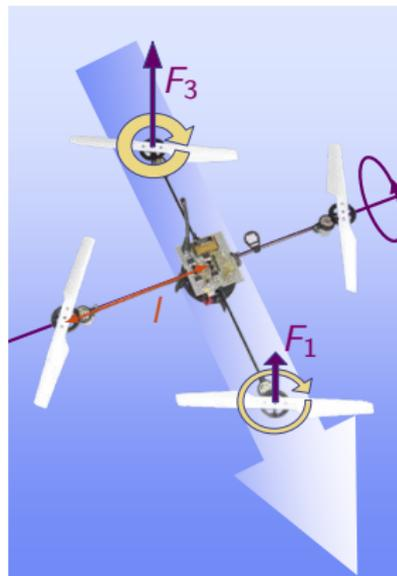

Example: the X4 helicopter

How it works ?

Robotics

N. Marchand

Introduction

Outline

Mechanics

Kinematics

Arm robots

Inner-loop

Geometrical
model

Kinematic model

Dynamical
model

Conclusion

Path planning

Workspace and
obstacles

path planning

Mobile
robotics

Visual
servoing

RX90 robot

- 4 fixed rotors with controlled rotation speed s_i
- 4 generated forces F_i
- 4 counter-rotating torques Γ_i
- **Roll movement** generated with a dissymmetry between left and right forces:

$$\Gamma_r = l(F_4 - F_2)$$

- **Pitch movement** generated with a dissymmetry between front and rear forces:

$$\Gamma_p = l(F_1 - F_3)$$

- **Yaw movement**

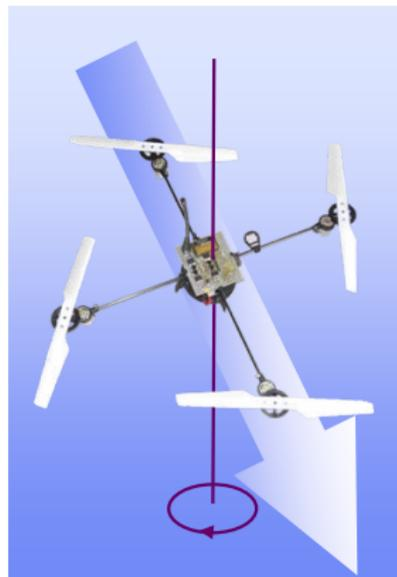

Example: the X4 helicopter

How it works ?

Robotics

N. Marchand

Introduction

Outline

Mechanics

Kinematics

Arm robots

Inner-loop

Geometrical model

Kinematic model

Dynamical model

Conclusion

Path planning

Workspace and obstacles

path planning

Mobile robotics

Visual servoing

RX90 robot

- 4 fixed rotors with controlled rotation speed s_i
- 4 generated forces F_i
- 4 counter-rotating torques Γ_i
- **Roll movement** generated with a dissymmetry between left and right forces:

$$\Gamma_r = l(F_4 - F_2)$$

- **Pitch movement** generated with a dissymmetry between front and rear forces:

$$\Gamma_p = l(F_1 - F_3)$$

- **Yaw movement** generated with a dissymmetry between front/rear and left/right torques:

$$\Gamma_y = \Gamma_1 + \Gamma_3 - \Gamma_2 - \Gamma_4$$

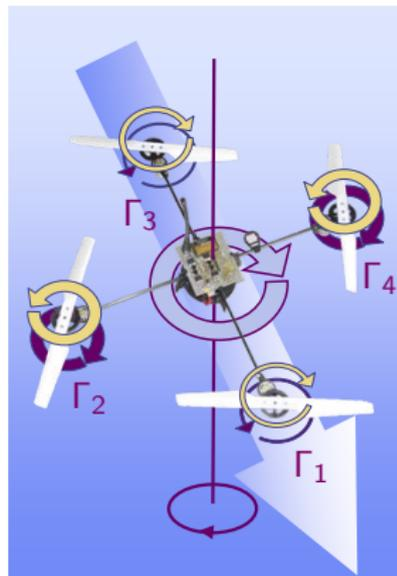

Example: the X4 helicopter

Building a model (1/3)

- **Electrical motor:** A 2nd order system with friction and saturation

Robotics

N. Marchand

Introduction

Outline

Mechanics

Kinematics

Arm robots
Inner-loop
Geometrical
model
Kinematic model
Dynamical
model
Conclusion

Path planning

Workspace and
obstacles
path planning

Mobile
robotics

Visual
servoing

RX90 robot

Example: the X4 helicopter

Building a model (1/3)

Robotics

N. Marchand

Introduction

Outline

Mechanics

Kinematics

Arm robots

Inner-loop

Geometrical
model

Kinematic model

Dynamical
model

Conclusion

Path planning

Workspace and
obstacles

path planning

Mobile

robotics

Visual

servoing

RX90 robot

- **Electrical motor:** A 2nd order system with friction and saturation usually *approximated* by a 1st order system:

$$\dot{s}_i = -\frac{k_m^2}{J_r R} s_i - \frac{1}{J_r} \tau_{\text{load}} + \frac{k_m}{J_r R} \text{sat}_{\bar{U}_i}(U_i) \quad i \in \{1, 2, 3, 4\} \quad (1)$$

s_i : rotation speed

U_i : voltage applied to the motor; **real control variable**

τ_{load} : motor load: $\tau_{\text{load}} = k_{\text{gearbox}} \kappa |s_i| s_i$ with κ drag coefficient

Example: the X4 helicopter

Building a model (1/3)

Robotics

N. Marchand

Introduction

Outline

Mechanics

Kinematics

Arm robots

Inner-loop

Geometrical model

Kinematic model

Dynamical model

Conclusion

Path planning

Workspace and obstacles

path planning

Mobile robotics

Visual servoing

RX90 robot

- **Electrical motor:** A 2nd order system with friction and saturation usually *approximated* by a 1st order system:

$$\dot{s}_i = -\frac{k_m^2}{J_r R} s_i - \frac{1}{J_r} \tau_{load} + \frac{k_m}{J_r R} \text{sat}_{\bar{U}_i}(U_i) \quad i \in \{1, 2, 3, 4\} \quad (1)$$

s_i : rotation speed

U_i : voltage applied to the motor; **real control variable**

τ_{load} : motor load: $\tau_{load} = k_{gearbox} \kappa |s_i| s_i$ with κ drag coefficient

- **Aerodynamical forces and torques:** Very complex models exist

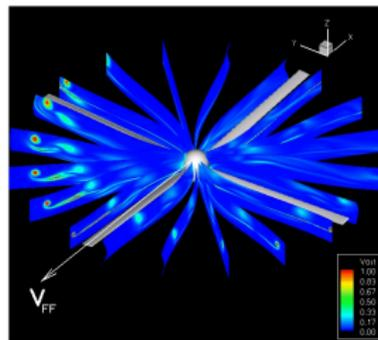
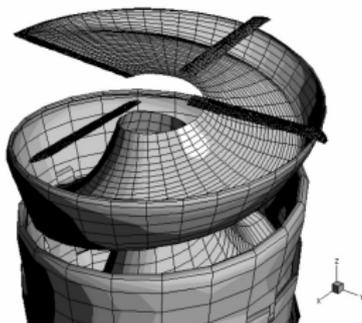



Example: the X4 helicopter

Building a model (1/3)

Robotics

N. Marchand

Introduction

Outline

Mechanics

Kinematics

Arm robots

Inner-loop

Geometrical
model

Kinematic model

Dynamical
model

Conclusion

Path planning

Workspace and
obstacles

path planning

Mobile
roboticsVisual
servoing

RX90 robot

- **Electrical motor:** A 2nd order system with friction and saturation usually *approximated* by a 1st order system:

$$\dot{s}_i = -\frac{k_m^2}{J_r R} s_i - \frac{1}{J_r} \tau_{\text{load}} + \frac{k_m}{J_r R} \text{sat}_{\bar{U}_i}(U_i) \quad i \in \{1, 2, 3, 4\} \quad (1)$$

 s_i : rotation speed U_i : voltage applied to the motor; **real control variable** τ_{load} : motor load: $\tau_{\text{load}} = k_{\text{gearbox}} \kappa |s_i| s_i$ with κ drag coefficient

- **Aerodynamical forces and torques:** Very complex models exist but overcomplicated for control, better use the *simplified* model:

$$\begin{aligned} F_i &= b s_i^2 \\ \Gamma_r &= l b (s_4^2 - s_2^2) \\ \Gamma_p &= l b (s_1^2 - s_3^2) \\ \Gamma_y &= \kappa (s_1^2 + s_3^2 - s_2^2 - s_4^2) \end{aligned} \quad i \in \{1, 2, 3, 4\} \quad (2)$$

 b : thrust coefficient, κ : drag coefficient

Example: the X4 helicopter

Building a model (2/3)

Robotics

N. Marchand

Introduction

Outline

Mechanics

Kinematics

Arm robots

Inner-loop

Geometrical
model

Kinematic model

Dynamical
model

Conclusion

Path planning

Workspace and
obstacles

path planning

Mobile
robotics

Visual
servoing

RX90 robot

- Two frames

- a fixed frame $E(\vec{e}_1, \vec{e}_2, \vec{e}_3)$
- a frame attached to the X4
 $T(\vec{t}_1, \vec{t}_2, \vec{t}_3)$

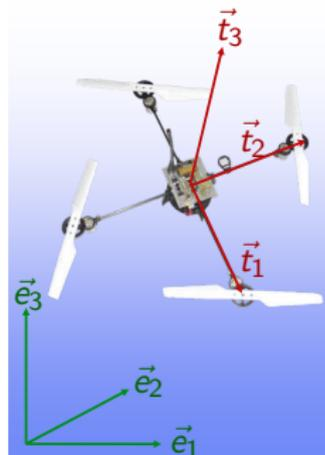



Example: the X4 helicopter

Building a model (2/3)

Robotics

N. Marchand

Introduction

Outline

Mechanics

Kinematics

Arm robots

Inner-loop

Geometrical
model

Kinematic model

Dynamical
model

Conclusion

Path planning

Workspace and
obstacles

path planning

Mobile

robotics

Visual

servoing

RX90 robot

- Two frames
 - a fixed frame $E(\vec{e}_1, \vec{e}_2, \vec{e}_3)$
 - a frame attached to the X4
 $T(\vec{t}_1, \vec{t}_2, \vec{t}_3)$
- Frame change
 - a rotation matrix R from T to E

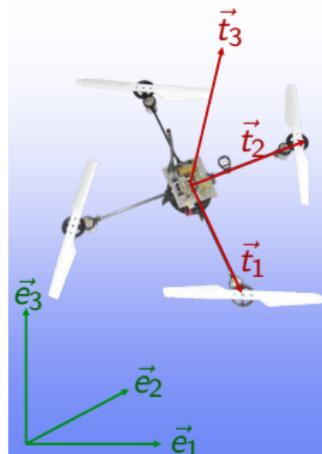

Example: the X4 helicopter

Building a model (2/3)

Robotics

N. Marchand

Introduction

Outline

Mechanics

Kinematics

Arm robots

Inner-loop

Geometrical
model

Kinematical model

Dynamical
model

Conclusion

Path planning

Workspace and
obstacles

path planning

Mobile

robotics

Visual

servoing

RX90 robot

- Two frames
 - a fixed frame $E(\vec{e}_1, \vec{e}_2, \vec{e}_3)$
 - a frame attached to the X4
 $T(\vec{t}_1, \vec{t}_2, \vec{t}_3)$
- Frame change
 - a rotation matrix R from T to E
- State variables:

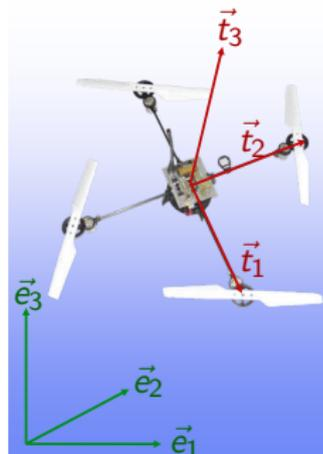

Example: the X4 helicopter

Building a model (2/3)

Robotics

N. Marchand

Introduction

Outline

Mechanics

Kinematics

Arm robots

Inner-loop

Geometrical
model

Kinematic model

Dynamical
model

Conclusion

Path planning

Workspace and
obstacles

path planning

Mobile

robotics

Visual

servoing

RX90 robot

- Two frames
 - a fixed frame $E(\vec{e}_1, \vec{e}_2, \vec{e}_3)$
 - a frame attached to the X4
 $T(\vec{t}_1, \vec{t}_2, \vec{t}_3)$
- Frame change
 - a rotation matrix R from T to E
- State variables:
 - Cartesian coordinates (in E)
 - position \vec{p}
 - velocity \vec{v}

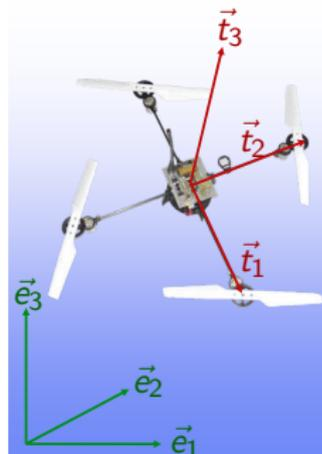

Example: the X4 helicopter

Building a model (2/3)

Robotics

N. Marchand

Introduction

Outline

Mechanics

Kinematics

Arm robots

Inner-loop

Geometrical
model

Kinematic model

Dynamical
model

Conclusion

Path planning

Workspace and
obstacles

path planning

Mobile
roboticsVisual
servoing

RX90 robot

- Two frames

- a fixed frame $E(\vec{e}_1, \vec{e}_2, \vec{e}_3)$
- a frame attached to the X4
 $T(\vec{t}_1, \vec{t}_2, \vec{t}_3)$

- Frame change

- a rotation matrix R from T to E

- State variables:

- Cartesian coordinates (in E)

- position \vec{p}
- velocity \vec{v}

- Attitude coordinates:

- angular velocity $\vec{\omega}$ in the moving frame T
- either: Euler angles three successive rotations about \vec{t}_3 , \vec{t}_1 and \vec{t}_3 of angles ϕ , θ and ψ giving R
- or: Quaternion representation $(q_0, \vec{q}) = (\cos \beta/2, \vec{u} \sin \beta/2)$ represent a rotation of angle β about \vec{u}

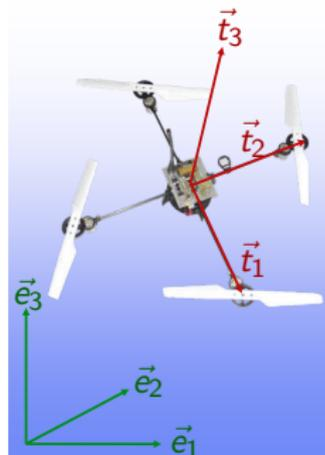

Example: the X4 helicopter

Building a model (3/3)

Robotics

N. Marchand

Introduction

Outline

Mechanics

Kinematics

Arm robots

Inner-loop

Geometrical
model

Kinematic model

Dynamical
model

Conclusion

Path planning

Workspace and
obstacles

path planning

Mobile

robotics

Visual

servoing

RX90 robot

- **Cartesian coordinates:**

$$\begin{cases} \dot{\vec{p}} = \vec{v} \\ m\dot{\vec{v}} = -mg\vec{e}_3 + R\left(\sum_i F_i(s_i)\vec{e}_3\right) \end{cases} \quad (3)$$



Example: the X4 helicopter

Building a model (3/3)

Robotics

N. Marchand

Introduction

Outline

Mechanics

Kinematics

Arm robots

Inner-loop

Geometrical
model

Kinematic model

Dynamical
model

Conclusion

Path planning

Workspace and
obstacles

path planning

Mobile
robotics

Visual
servoing

RX90 robot

- **Cartesian coordinates:**

$$\begin{cases} \dot{\vec{p}} = \vec{v} \\ m\dot{\vec{v}} = -mg\vec{e}_3 + R\left(\sum_i F_i(s_i)\vec{e}_3\right) \end{cases} \quad (3)$$

- **Attitude:**



Example: the X4 helicopter

Building a model (3/3)

Robotics

N. Marchand

Introduction

Outline

Mechanics

Kinematics

Arm robots

Inner-loop

Geometrical
model

Kinematic model

Dynamical
model

Conclusion

Path planning

Workspace and
obstacles

path planning

Mobile
robotics

Visual
servoing

RX90 robot

- **Cartesian coordinates:**

$$\begin{cases} \dot{\vec{p}} = \vec{v} \\ m\dot{\vec{v}} = -mg\vec{e}_3 + R\left(\sum_i F_i(s_i)\vec{e}_3\right) \end{cases} \quad (3)$$

- **Attitude:**

- Euler angles formalism:

$$\begin{cases} \dot{R} = R\vec{\omega}^\times \\ J\dot{\vec{\omega}} = -\vec{\omega}^\times J\vec{\omega} + \Gamma_{\text{tot}} \end{cases} \quad \text{with } \vec{\omega}^\times = \begin{pmatrix} 0 & -\omega_3 & \omega_2 \\ \omega_3 & 0 & -\omega_1 \\ -\omega_2 & \omega_1 & 0 \end{pmatrix} \quad (4)$$

$\vec{\omega}^\times$ is the skew symmetric tensor associated to $\vec{\omega}$



Example: the X4 helicopter

Building a model (3/3)

Robotics

N. Marchand

Introduction

Outline

Mechanics

Kinematics

Arm robots

Inner-loop

Geometrical
model

Kinematic model

Dynamical
model

Conclusion

Path planning

Workspace and
obstacles

path planning

Mobile
robotics

Visual
servoing

RX90 robot

- **Cartesian coordinates:**

$$\begin{cases} \dot{\vec{p}} = \vec{v} \\ m\dot{\vec{v}} = -mg\vec{e}_3 + R\left(\sum_i F_i(s_i)\vec{e}_3\right) \end{cases} \quad (3)$$

- **Attitude:**

- Euler angles formalism:

$$\begin{cases} \dot{R} = R\vec{\omega}^\times \\ J\dot{\vec{\omega}} = -\vec{\omega}^\times J\vec{\omega} + \Gamma_{\text{tot}} \end{cases} \quad \text{with } \vec{\omega}^\times = \begin{pmatrix} 0 & -\omega_3 & \omega_2 \\ \omega_3 & 0 & -\omega_1 \\ -\omega_2 & \omega_1 & 0 \end{pmatrix} \quad (4)$$

$\vec{\omega}^\times$ is the skew symmetric tensor associated to $\vec{\omega}$

- Quaternion formalism:

$$\begin{cases} \dot{q} = \frac{1}{2}\Omega(\vec{\omega})q \\ \dot{\Xi}(q) = \frac{1}{2}\Xi(q)\vec{\omega} \\ J\dot{\vec{\omega}} = -\vec{\omega}^\times J\vec{\omega} + \Gamma_{\text{tot}} \end{cases} \quad \text{with } \begin{cases} \Omega(\vec{\omega}) = \begin{pmatrix} 0 & -\vec{\omega}^T \\ \vec{\omega} & -\vec{\omega}^\times \end{pmatrix} \\ \Xi(q) = \begin{pmatrix} -\vec{q}^T \\ \mathbf{I}_{3 \times 3}q_0 + \vec{q}^\times \end{pmatrix} \end{cases} \quad (5)$$



Example: the X4 helicopter

Building a model (3/3)

Robotics

N. Marchand

Introduction

Outline

Mechanics

Kinematics

Arm robots

Inner-loop

Geometrical
model

Kinematic model

Dynamical
model

Conclusion

Path planning

Workspace and
obstacles

path planning

Mobile
roboticsVisual
servoing

RX90 robot

- **Cartesian coordinates:**

$$\begin{cases} \dot{\vec{p}} = \vec{v} \\ m\dot{\vec{v}} = -mg\vec{e}_3 + R\left(\sum_i F_i(s_i)\vec{t}_3\right) \end{cases} \quad (3)$$

- **Attitude:**

- Euler angles formalism:

$$\begin{cases} \dot{R} = R\vec{\omega}^\times \\ J\dot{\vec{\omega}} = -\vec{\omega}^\times J\vec{\omega} + \Gamma_{\text{tot}} \end{cases} \quad \text{with } \vec{\omega}^\times = \begin{pmatrix} 0 & -\omega_3 & \omega_2 \\ \omega_3 & 0 & -\omega_1 \\ -\omega_2 & \omega_1 & 0 \end{pmatrix} \quad (4)$$

$\vec{\omega}^\times$ is the skew symmetric tensor associated to $\vec{\omega}$

- Quaternion formalism:

$$\begin{cases} \dot{\vec{q}} = \frac{1}{2}\Omega(\vec{\omega})\vec{q} \\ \dot{\Xi} = \frac{1}{2}\Xi(\vec{q})\vec{\omega} \\ J\dot{\vec{\omega}} = -\vec{\omega}^\times J\vec{\omega} + \Gamma_{\text{tot}} \end{cases} \quad \text{with } \begin{cases} \Omega(\vec{\omega}) = \begin{pmatrix} 0 & -\vec{\omega}^T \\ \vec{\omega} & -\vec{\omega}^\times \end{pmatrix} \\ \Xi(\vec{q}) = \begin{pmatrix} -\vec{q}^T \\ \mathbb{I}_{3 \times 3} \mathbf{q}_0 + \vec{q}^\times \end{pmatrix} \end{cases} \quad (5)$$

$$\text{where } \Gamma_{\text{tot}} = \underbrace{-\sum_i I_r \vec{\omega}^\times \vec{t}_3 s_i}_{\text{gyroscopic torque}} + \Gamma_{\text{pert}} + \begin{pmatrix} \Gamma_r(s_2, s_4) \\ \Gamma_p(s_1, s_3) \\ \Gamma_y(s_1, s_2, s_3, s_4) \end{pmatrix}$$



Example: the X4 helicopter

Review of the nonlinearities

Robotics

N. Marchand

Introduction

Outline

Mechanics

Kinematics

Arm robots

Inner-loop

Geometrical
model

Kinematic model

Dynamical
model

Conclusion

Path planning

Workspace and
obstacles

path planning

Mobile

robotics

Visual

servoing

RX90 robot

$$\left\{ \begin{array}{l} \dot{s}_i = -\frac{k_m^2}{J_r R} s_i - \frac{k_{gearbox} \kappa_i}{J_r} |s_i| s_i + \frac{k_m}{J_r R} \text{sat} \bar{u}_i(U_i) \\ \dot{\vec{p}} = \vec{v} \\ m \dot{\vec{v}} = -mg \vec{e}_3 + R \begin{pmatrix} 0 \\ 0 \\ \sum_i F_i(s_i) \end{pmatrix} \\ \dot{R} = R \vec{\omega}^\times \\ J \dot{\vec{\omega}} = -\vec{\omega}^\times J \vec{\omega} - \sum_i I_r \vec{\omega}^\times \begin{pmatrix} 0 \\ 0 \\ \sum_i s_i \end{pmatrix} + \begin{pmatrix} \Gamma_r(s_2, s_4) \\ \Gamma_p(s_1, s_3) \\ \Gamma_y(s_1, s_2, s_3, s_4) \end{pmatrix} \end{array} \right.$$

Example: the X4 helicopter

Review of the nonlinearities

Robotics

N. Marchand

Introduction

Outline

Mechanics

Kinematics

Arm robots

Inner-loop

Geometrical model

Kinematic model

Dynamical model

Conclusion

Path planning

Workspace and obstacles

path planning

Mobile robotics

robotics

Visual servoing

robotics

RX90 robot

$$\left\{ \begin{array}{l}
 \dot{s}_i = -\frac{k_m^2}{J_r R} s_i - \frac{k_{gearbox} \kappa_i}{J_r} |s_i| s_i + \frac{k_m}{J_r R} \text{sat}_{\bar{U}_i}(U_i) \\
 \dot{\vec{p}} = \vec{v} \\
 m \dot{\vec{v}} = -mg \vec{e}_3 + R \left(\begin{array}{c} 0 \\ 0 \\ \sum_i F_i(s_i) \end{array} \right) \\
 \dot{R} = R \vec{\omega}^\times \\
 J \dot{\vec{\omega}} = -\vec{\omega}^\times J \vec{\omega} - \sum_i I_r \vec{\omega}^\times \left(\begin{array}{c} 0 \\ 0 \\ \sum_i s_i \end{array} \right) + \left(\begin{array}{c} \Gamma_r(s_2, s_4) \\ \Gamma_\rho(s_1, s_3) \\ \Gamma_y(s_1, s_2, s_3, s_4) \end{array} \right)
 \end{array} \right.$$

In red: the nonlinearities

In blue: where the control variables act



Example: the X4 helicopter

Identification of the parameters

Robotics

N. Marchand

Introduction

Outline

Mechanics

Kinematics

Arm robots

Inner-loop

Geometrical
model

Kinematic model

Dynamical
model

Conclusion

Path planning

Workspace and
obstacles

path planning

Mobile

robotics

Visual

servoing

RX90 robot

- **Electrical motor:**

- For small input steps, the system behaves very close to a **linear** first order system
- Hence, use linear identification tools
- \bar{U}_i is found on the data-sheet of the motor (damage avoidance)

Example: the X4 helicopter

Identification of the parameters

Robotics

N. Marchand

Introduction

Outline

Mechanics

Kinematics

Arm robots
 Inner-loop
 Geometrical model
 Kinematic model
 Dynamical model
 Conclusion

Path planning

Workspace and obstacles
 path planning

Mobile robotics

Visual servoing

RX90 robot

- **Electrical motor:**

- For small input steps, the system behaves very close to a **linear** first order system
- Hence, use linear identification tools
- \bar{U}_i is found on the data-sheet of the motor (damage avoidance)

- **Aerodynamical parameters:** b and κ

b and κ measured with specific test beds, depends upon temperature, distance from ground, etc.



Example: the X4 helicopter

Identification of the parameters

Robotics

N. Marchand

Introduction

Outline

Mechanics

Kinematics

- Arm robots
- Inner-loop
- Geometrical model
- Kinematic model
- Dynamical model
- Conclusion

Path planning

- Workspace and obstacles
- path planning

Mobile robotics

Visual servoing

RX90 robot

- **Electrical motor:**

- For small input steps, the system behaves very close to a **linear** first order system
- Hence, use linear identification tools
- \bar{U}_i is found on the data-sheet of the motor (damage avoidance)

- **Aerodynamical parameters:** b and κ

b and κ measured with specific test beds, depends upon temperature, distance from ground, etc.



Example: the X4 helicopter

Identification of the parameters

Robotics

N. Marchand

Introduction

Outline

Mechanics

Kinematics

 Arm robots
 Inner-loop
 Geometrical model
 Kinematic model
 Dynamical model
 Conclusion

Path planning

 Workspace and obstacles
 path planning

Mobile robotics

Visual servoing

RX90 robot

- **Electrical motor:**

- For small input steps, the system behaves very close to a **linear** first order system
- Hence, use linear identification tools
- \bar{U}_i is found on the data-sheet of the motor (damage avoidance)

- **Aerodynamical parameters:** b and κ

b and κ measured with specific test beds, depends upon temperature, distance from ground, etc.

- **Mechanical parameters:**

Example: the X4 helicopter

Identification of the parameters

Robotics

N. Marchand

Introduction

Outline

Mechanics

Kinematics

 Arm robots
 Inner-loop
 Geometrical
 model
 Kinematic model
 Dynamical
 model
 Conclusion

Path planning

 Workspace and
 obstacles
 path planning

 Mobile
 robotics

 Visual
 servoing

RX90 robot

- **Electrical motor:**

- For small input steps, the system behaves very close to a **linear** first order system
- Hence, use linear identification tools
- \bar{U}_i is found on the data-sheet of the motor (damage avoidance)

- **Aerodynamical parameters:** b and κ

b and κ measured with specific test beds, depends upon temperature, distance from ground, etc.

- **Mechanical parameters:**

l length of an arm of the helicopter, easy to measure

Example: the X4 helicopter

Identification of the parameters

Robotics

N. Marchand

Introduction

Outline

Mechanics

Kinematics

Arm robots
Inner-loop
Geometrical
model
Kinematic model
Dynamical
model
Conclusion

Path planning

Workspace and
obstacles
path planning

Mobile
robotics

Visual
servoing

RX90 robot

- **Electrical motor:**

- For small input steps, the system behaves very close to a **linear** first order system
- Hence, use linear identification tools
- \bar{U}_i is found on the data-sheet of the motor (damage avoidance)

- **Aerodynamical parameters:** b and κ

b and κ measured with specific test beds, depends upon temperature, distance from ground, etc.

- **Mechanical parameters:**

- l length of an arm of the helicopter, easy to measure
- m total mass of the helicopter, easy to measure

Example: the X4 helicopter

Identification of the parameters

Robotics

N. Marchand

Introduction

Outline

Mechanics

Kinematics

Arm robots
Inner-loop
Geometrical
model
Kinematic model
Dynamical
model
Conclusion

Path planning

Workspace and
obstacles
path planning

Mobile
robotics

Visual
servoing

RX90 robot

- **Electrical motor:**

- For small input steps, the system behaves very close to a **linear** first order system
- Hence, use linear identification tools
- \bar{U}_i is found on the data-sheet of the motor (damage avoidance)

- **Aerodynamical parameters:** b and κ

b and κ measured with specific test beds, depends upon temperature, distance from ground, etc.

- **Mechanical parameters:**

- l length of an arm of the helicopter, easy to measure
- m total mass of the helicopter, easy to measure
- J body inertia, hard to have precisely

Example: the X4 helicopter

Identification of the parameters

Robotics

N. Marchand

Introduction

Outline

Mechanics

Kinematics

Arm robots
 Inner-loop
 Geometrical model
 Kinematic model
 Dynamical model
 Conclusion

Path planning

Workspace and obstacles
 path planning

Mobile
 robotics

Visual
 servoing

RX90 robot

- **Electrical motor:**

- For small input steps, the system behaves very close to a **linear** first order system
- Hence, use linear identification tools
- \bar{U}_i is found on the data-sheet of the motor (damage avoidance)

- **Aerodynamical parameters:** b and κ

b and κ measured with specific test beds, depends upon temperature, distance from ground, etc.

- **Mechanical parameters:**

- l length of an arm of the helicopter, easy to measure
- m total mass of the helicopter, easy to measure
- J body inertia, hard to have precisely
- I_r rotor inertia, hard to have precisely



Example: the X4 helicopter

Values of the parameters

Robotics

N. Marchand

- **Motor parameters:**

parameter	description	value	unit
k_m	motor constant	4.3×10^{-3}	N.m/A
J_r	rotor inertia	3.4×10^{-5}	J.g.m ²
R	motor resistance	0.67	Ω
$k_{gearbox}$	gearbox ratio	2.7×10^{-3}	-
\bar{U}_i	maximal voltage	12	V

Introduction

Outline

Mechanics

Kinematics

Arm robots

Inner-loop

Geometrical
model

Kinematic model

Dynamical
model

Conclusion

Path planning

Workspace and
obstacles

path planning

Mobile

robotics

Visual

servoing

RX90 robot



Example: the X4 helicopter

Values of the parameters

Robotics

N. Marchand

Introduction

Outline

Mechanics

Kinematics

Arm robots

Inner-loop

Geometrical
model

Kinematic model

Dynamical
model

Conclusion

Path planning

Workspace and
obstacles

path planning

Mobile
robotics

Visual
servoing

RX90 robot

● Motor parameters:

parameter	description	value	unit
k_m	motor constant	4.3×10^{-3}	N.m/A
J_r	rotor inertia	3.4×10^{-5}	J.g.m ²
R	motor resistance	0.67	Ω
$k_{gearbox}$	gearbox ratio	2.7×10^{-3}	-
\bar{U}_i	maximal voltage	12	V

● Aerodynamical parameters:

parameter	description	value
b	thrust coefficient	3.8×10^{-6}
κ	drag coefficient	2.9×10^{-5}

Example: the X4 helicopter

Values of the parameters

Robotics

N. Marchand

Introduction

Outline

Mechanics

Kinematics

Arm robots

Inner-loop

Geometrical model

Kinematic model

Dynamical model

Conclusion

Path planning

Workspace and obstacles

path planning

Mobile robotics

Visual servoing

RX90 robot

● Motor parameters:

parameter	description	value	unit
k_m	motor constant	4.3×10^{-3}	N.m/A
J_r	rotor inertia	3.4×10^{-5}	J.g.m ²
R	motor resistance	0.67	Ω
$k_{gearbox}$	gearbox ratio	2.7×10^{-3}	-
U_i	maximal voltage	12	V

● Aerodynamical parameters:

parameter	description	value
b	thrust coefficient	3.8×10^{-6}
κ	drag coefficient	2.9×10^{-5}

● Body parameters:

parameter	description	value	unit
J	inertia matrix	$\begin{pmatrix} 14.6 \times 10^{-3} & 0 & 0 \\ 0 & 7.8 \times 10^{-3} & 0 \\ 0 & 0 & 7.8 \times 10^{-3} \end{pmatrix}$	kg.m ²
m	mass of the UAV	0.458	kg
l	radius of the UAV	22.5	cm
g	gravity	9.81	m/s ²

Robotics

N. Marchand

Introduction

Outline

Mechanics

Kinematics

Arm robots

Inner-loop

Geometrical
model

Kinematic model

Dynamical
model

Conclusion

Path planning

Workspace and
obstacles

path planning

Mobile
robotics

robotics

Visual
servoing

servoing

RX90 robot

- 1 Introduction
- 2 Outline
- 3 Mechanics basis
- 4 Kinematics and dynamics of robots**
 - Arm robots
 - Inner-loop
 - Geometrical model
 - Kinematic model
 - Dynamical model
 - Conclusion
- 5 Path planning
 - Workspace and obstacles
 - Path planning problem formulation
- 6 Mobile robotics
- 7 Visual servoing
- 8 Stäubli RX90 robot



JOINTED-ARM ROBOTS

- Jointed-arm robot: A robot whose arm is constructed of rigid members connected by rotary joints

Robotics

N. Marchand

Introduction

Outline

Mechanics

Kinematics

Arm robots

Inner-loop

Geometrical
model

Kinematic model

Dynamical
model

Conclusion

Path planning

Workspace and
obstacles

path planning

Mobile

robotics

Visual

servoing

RX90 robot



JOINTED-ARM ROBOTS

Robotics

N. Marchand

- Jointed-arm robot: A robot whose arm is constructed of rigid members connected by rotary joints
- Two possible rotary joints:

Introduction

Outline

Mechanics

Kinematics

Arm robots

Inner-loop

Geometrical
model

Kinematic model

Dynamical
model

Conclusion

Path planning

Workspace and
obstacles

path planning

Mobile

robotics

Visual

servoing

RX90 robot



JOINTED-ARM ROBOTS

Robotics

N. Marchand

Introduction

Outline

Mechanics

Kinematics

Arm robots

Inner-loop

Geometrical
model

Kinematic model

Dynamical
model

Conclusion

Path planning

Workspace and
obstacles

path planning

Mobile
robotics

Visual
servoing

RX90 robot

- Jointed-arm robot: A robot whose arm is constructed of rigid members connected by rotary joints
- Two possible rotary joints:
 - rotary around the arm





JOINTED-ARM ROBOTS

Robotics

N. Marchand

Introduction

Outline

Mechanics

Kinematics

Arm robots

Inner-loop

Geometrical
model

Kinematic model

Dynamical
model

Conclusion

Path planning

Workspace and
obstacles

path planning

Mobile
robotics

Visual
servoing

RX90 robot

- Jointed-arm robot: A robot whose arm is constructed of rigid members connected by rotary joints
- Two possible rotary joints:
 - rotary around the arm



- rotary perpendicular to the arm





JOINTED-ARM ROBOTS

Robotics

N. Marchand

Introduction

Outline

Mechanics

Kinematics

Arm robots

Inner-loop

Geometrical
model

Kinematic model

Dynamical
model

Conclusion

Path planning

Workspace and
obstacles

path planning

Mobile
robotics

Visual
servoing

RX90 robot

- Jointed-arm robot: A robot whose arm is constructed of rigid members connected by rotary joints
- Two possible rotary joints:
 - rotary around the arm



- rotary perpendicular to the arm



- Each possible movement is called a **degree of freedom (dof)**



JOINTED-ARM ROBOTS

Robotics

N. Marchand

Introduction

Outline

Mechanics

Kinematics

Arm robots

Inner-loop

Geometrical
model

Kinematic model

Dynamical
model

Conclusion

Path planning

Workspace and
obstacles

path planning

Mobile
robotics

Visual
servoing

RX90 robot

- Jointed-arm robot: A robot whose arm is constructed of rigid members connected by rotary joints
- Two possible rotary joints:
 - rotary around the arm



- rotary perpendicular to the arm

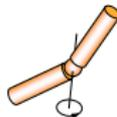

- Each possible movement is called a **degree of freedom (dof)**
- Sometimes movements are coupled (more than 1 dof/articulation)



JOINTED-ARM ROBOTS

Robotics

N. Marchand

Introduction

Outline

Mechanics

Kinematics

- Arm robots
- Inner-loop
- Geometrical model
- Kinematic model
- Dynamical model
- Conclusion

Path planning

- Workspace and obstacles
- path planning

Mobile robotics

Visual servoing

RX90 robot

- Jointed-arm robot: A robot whose arm is constructed of rigid members connected by rotary joints
- Two possible rotary joints:
 - rotary around the arm



- rotary perpendicular to the arm



- Each possible movement is called a **degree of freedom (dof)**
- Sometimes movements are coupled (more than 1 dof/articulation)
- A “universal” robot has 12 dof:

JOINTED-ARM ROBOTS

Robotics

N. Marchand

Introduction

Outline

Mechanics

Kinematics

- Arm robots
- Inner-loop
- Geometrical model
- Kinematic model
- Dynamical model
- Conclusion

Path planning

- Workspace and obstacles
- path planning

Mobile robotics

Visual servoing

RX90 robot

- Jointed-arm robot: A robot whose arm is constructed of rigid members connected by rotary joints
- Two possible rotary joints:
 - rotary around the arm



- rotary perpendicular to the arm



- Each possible movement is called a **degree of freedom (dof)**
- Sometimes movements are coupled (more than 1 dof/articulation)
- A “universal” robot has 12 dof:
 - 6 for spatial position (vehicle)



JOINTED-ARM ROBOTS

Robotics

N. Marchand

Introduction

Outline

Mechanics

Kinematics

Arm robots

Inner-loop

Geometrical
model

Kinematic model

Dynamical
model

Conclusion

Path planning

Workspace and
obstacles
path planning

Mobile
robotics

Visual
servoing

RX90 robot

- Jointed-arm robot: A robot whose arm is constructed of rigid members connected by rotary joints
- Two possible rotary joints:
 - rotary around the arm



- rotary perpendicular to the arm



- Each possible movement is called a **degree of freedom (dof)**
- Sometimes movements are coupled (more than 1 dof/articulation)
- A “universal” robot has 12 dof:
 - 6 for spatial position (vehicle)
 - 3 for the arm



JOINTED-ARM ROBOTS

Robotics

N. Marchand

Introduction

Outline

Mechanics

Kinematics

Arm robots

Inner-loop

Geometrical
model

Kinematic model

Dynamical
model

Conclusion

Path planning

Workspace and
obstacles
path planning

Mobile
robotics

Visual
servoing

RX90 robot

- Jointed-arm robot: A robot whose arm is constructed of rigid members connected by rotary joints
- Two possible rotary joints:
 - rotary around the arm



- rotary perpendicular to the arm



- Each possible movement is called a **degree of freedom (dof)**
- Sometimes movements are coupled (more than 1 dof/articulation)
- A “universal” robot has 12 dof:
 - 6 for spatial position (vehicle)
 - 3 for the arm
 - 3 for the terminal tool



JOINTED-ARM ROBOTS

Robotics

N. Marchand

Introduction

Outline

Mechanics

Kinematics

Arm robots

Inner-loop

Geometrical
model

Kinematic model

Dynamical
model

Conclusion

Path planning

Workspace and
obstacles
path planning

Mobile
robotics

Visual
servoing

RX90 robot

- Jointed-arm robot: A robot whose arm is constructed of rigid members connected by rotary joints
- Two possible rotary joints:
 - rotary around the arm



- rotary perpendicular to the arm



- Each possible movement is called a **degree of freedom (dof)**
- Sometimes movements are coupled (more than 1 dof/articulation)
- A “universal” robot has 12 dof:
 - 6 for spatial position (vehicle)
 - 3 for the arm
 - 3 for the terminal tool
- In the industrial context, a polyvalent robot will have 6 dof

JOINTED-ARM ROBOTS

Robotics

N. Marchand

Introduction

Outline

Mechanics

Kinematics

Arm robots

Inner-loop

Geometrical model

Kinematic model

Dynamical model

Conclusion

Path planning

Workspace and obstacles

path planning

Mobile

robotics

Visual

servoing

RX90 robot

- Jointed-arm robot: A robot whose arm is constructed of rigid members connected by rotary joints
- Two possible rotary joints:
 - rotary around the arm



- rotary perpendicular to the arm



- Each possible movement is called a **degree of freedom (dof)**
- Sometimes movements are coupled (more than 1 dof/articulation)
- A “universal” robot has 12 dof:
 - 6 for spatial position (vehicle)
 - 3 for the arm
 - 3 for the terminal tool
- In the industrial context, a polyvalent robot will have 6 dof
- 6 dof are sufficient for any position and orientation of the terminal tool in the *reachable space*

JOINTED-ARM ROBOTS

Robotics

N. Marchand

Introduction

Outline

Mechanics

Kinematics

Arm robots

Inner-loop

Geometrical
model

Kinematic model

Dynamical
model

Conclusion

Path planning

Workspace and
obstacles
path planning

Mobile
robotics

Visual
servoing

RX90 robot

- Jointed-arm robot: A robot whose arm is constructed of rigid members connected by rotary joints
- Two possible rotary joints:
 - rotary around the arm



- rotary perpendicular to the arm



- Each possible movement is called a **degree of freedom (dof)**
- Sometimes movements are coupled (more than 1 dof/articulation)
- A “universal” robot has 12 dof:
 - 6 for spatial position (vehicle)
 - 3 for the arm
 - 3 for the terminal tool
- In the industrial context, a polyvalent robot will have 6 dof
- 6 dof are sufficient for any position and orientation of the terminal tool in the *reachable space*
- Many tasks can be performed with less than 6 dof: “pick and place” needs only 4 dof

JOINTED-ARM ROBOTS

Robotics

N. Marchand

Introduction

Outline

Mechanics

Kinematics

Arm robots

Inner-loop

Geometrical
model

Kinematic model

Dynamical
model

Conclusion

Path planning

Workspace and
obstacles

path planning

Mobile

robotics

Visual

servoing

RX90 robot

- Characteristic variables:

JOINTED-ARM ROBOTS

Robotics

N. Marchand

Introduction

Outline

Mechanics

Kinematics

Arm robots

Inner-loop

Geometrical
model

Kinematic model

Dynamical
model

Conclusion

Path planning

Workspace and
obstacles

path planning

Mobile

robotics

Visual

servoing

RX90 robot

- Characteristic variables:
 - Actuator control u_i of the joint i

JOINTED-ARM ROBOTS

Robotics

N. Marchand

Introduction

Outline

Mechanics

Kinematics

- Arm robots
- Inner-loop
- Geometrical model
- Kinematic model
- Dynamical model
- Conclusion

Path planning

- Workspace and obstacles
- path planning

Mobile robotics

Visual servoing

RX90 robot

- Characteristic variables:
 - Actuator control u_i of the joint i
 - Actuator torques C_i of the joint i

Robotics

N. Marchand

Introduction

Outline

Mechanics

Kinematics

- Arm robots
- Inner-loop
- Geometrical model
- Kinematic model
- Dynamical model
- Conclusion

Path planning

- Workspace and obstacles
- path planning

Mobile robotics

Visual servoing

RX90 robot

- Characteristic variables:
 - Actuator control u_i of the joint i
 - Actuator torques C_i of the joint i
 - Angles θ_i of the joint



JOINTED-ARM ROBOTS

Robotics

N. Marchand

Introduction

Outline

Mechanics

Kinematics

- Arm robots
- Inner-loop
- Geometrical model
- Kinematic model
- Dynamical model
- Conclusion

Path planning

- Workspace and obstacles
- path planning

Mobile robotics

Visual servoing

RX90 robot

- Characteristic variables:
 - Actuator control u_i of the joint i
 - Actuator torques C_i of the joint i
 - Angles θ_i of the joint
 - Spatial position X_i of the extremity of the joint

JOINTED-ARM ROBOTS

Robotics

N. Marchand

Introduction

Outline

Mechanics

Kinematics

- Arm robots
- Inner-loop
- Geometrical model
- Kinematic model
- Dynamical model
- Conclusion

Path planning

- Workspace and obstacles
- path planning

Mobile robotics

Visual servoing

RX90 robot

- Characteristic variables:
 - Actuator control u_i of the joint i
 - Actuator torques C_i of the joint i
 - Angles θ_i of the joint
 - Spatial position X_i of the extremity of the joint
- Controlling a robot is equivalent to mastering the relation

$$u_i \Leftrightarrow C_i \Leftrightarrow \theta_i \Leftrightarrow X_i$$

JOINTED-ARM ROBOTS

Robotics

N. Marchand

Introduction

Outline

Mechanics

Kinematics

Arm robots

Inner-loop

Geometrical
model

Kinematic model

Dynamical
model

Conclusion

Path planning

Workspace and
obstacles
path planning

Mobile
robotics

Visual
servoing

RX90 robot

- Characteristic variables:
 - Actuator control u_i of the joint i
 - Actuator torques C_i of the joint i
 - Angles θ_i of the joint
 - Spatial position X_i of the extremity of the joint
- Controlling a robot is equivalent to mastering the relation

$$u_i \Leftrightarrow C_i \Leftrightarrow \theta_i \Leftrightarrow X_i$$

- Actuator's dynamics 

JOINTED-ARM ROBOTS

Robotics

N. Marchand

Introduction

Outline

Mechanics

Kinematics

Arm robots

Inner-loop

Geometrical
model

Kinematic model

Dynamical
model

Conclusion

Path planning

Workspace and
obstacles
path planning

Mobile
robotics

Visual
servoing

RX90 robot

- Characteristic variables:
 - Actuator control u_i of the joint i
 - Actuator torques C_i of the joint i
 - Angles θ_i of the joint
 - Spatial position X_i of the extremity of the joint
- Controlling a robot is equivalent to mastering the relation

$$u_i \Leftrightarrow C_i \Leftrightarrow \theta_i \Leftrightarrow X_i$$

- Actuator's dynamics 
- Robot's dynamics 

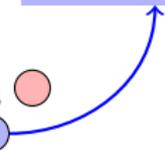

Robotics

N. Marchand

Introduction

Outline

Mechanics

Kinematics

Arm robots

Inner-loop

Geometrical
model

Kinematic model
Dynamical
model

Conclusion

Path planning

Workspace and
obstacles
path planning

Mobile
robotics

Visual
servoing

RX90 robot

- 1 Introduction
- 2 Outline
- 3 Mechanics basis
- 4 Kinematics and dynamics of robots**
 - Arm robots
 - Inner-loop**
 - Geometrical model
 - Kinematic model
 - Dynamical model
 - Conclusion
- 5 Path planning
 - Workspace and obstacles
 - Path planning problem formulation
- 6 Mobile robotics
- 7 Visual servoing
- 8 Stäubli RX90 robot



INNER CONTROL LOOP

Robotics

N. Marchand

- Inner control loop:

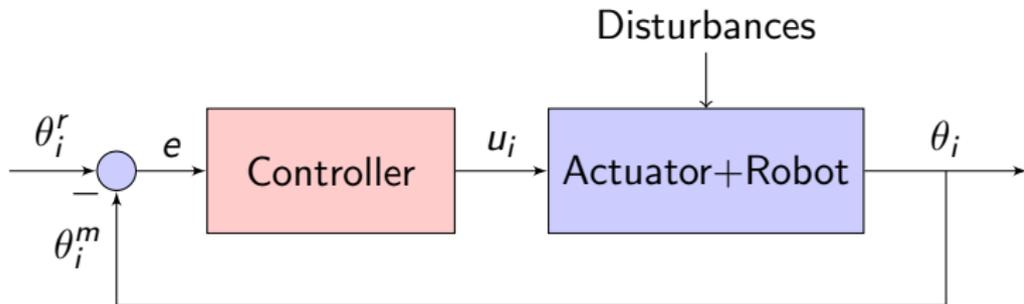

Introduction

Outline

Mechanics

Kinematics

Arm robots

Inner-loop

Geometrical
model

Kinematic model

Dynamical
model

Conclusion

Path planning

Workspace and
obstacles

path planning

Mobile

robotics

Visual

servoing

RX90 robot



INNER CONTROL LOOP

Robotics

N. Marchand

Introduction

Outline

Mechanics

Kinematics

Arm robots
Inner-loop
 Geometrical model
 Kinematic model
 Dynamical model
 Conclusion

Path planning

Workspace and obstacles
 path planning

Mobile robotics

Visual servoing

RX90 robot

- Inner control loop:

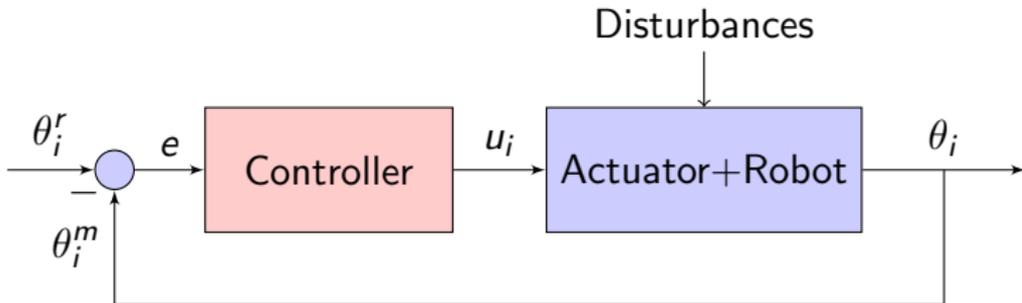

- Enables to force θ to follow the reference θ_r



INNER CONTROL LOOP

Robotics

N. Marchand

Introduction

Outline

Mechanics

Kinematics

Arm robots

Inner-loop

Geometrical
model

Kinematic model

Dynamical
model

Conclusion

Path planning

Workspace and
obstacles
path planning

Mobile
robotics

Visual
servoing

RX90 robot

- Inner control loop:

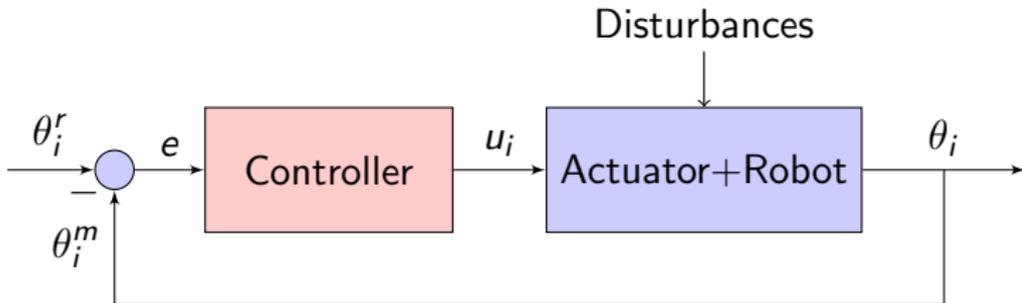

- Enables to force θ to follow the reference θ_r
- The actuator is usually a first (electric) or second order system (pneumatic)



INNER CONTROL LOOP

Robotics

N. Marchand

Introduction

Outline

Mechanics

Kinematics

Arm robots
Inner-loop
 Geometrical model
 Kinematic model
 Dynamical model
 Conclusion

Path planning

Workspace and obstacles
 path planning

Mobile robotics

Visual servoing

RX90 robot

- Inner control loop:

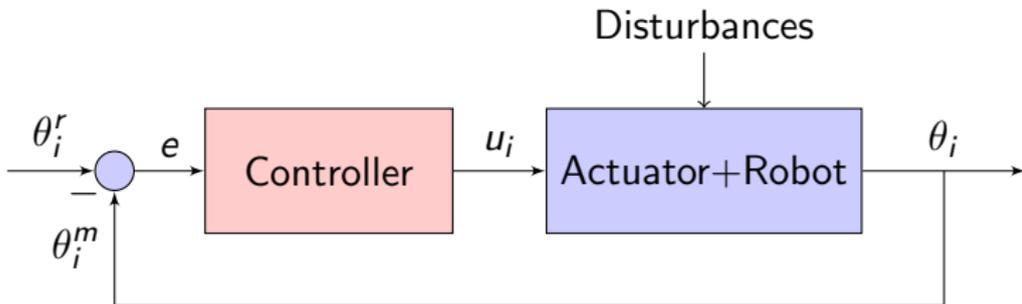

- Enables to force θ to follow the reference θ_r
- The actuator is usually a first (electric) or second order system (pneumatic)
- Usually controlled with a PID controller with



INNER CONTROL LOOP

Robotics

N. Marchand

Introduction

Outline

Mechanics

Kinematics

Arm robots
 Inner-loop
 Geometrical model
 Kinematic model
 Dynamical model
 Conclusion

Path planning

Workspace and obstacles
 path planning

Mobile robotics

Visual servoing

RX90 robot

- Inner control loop:

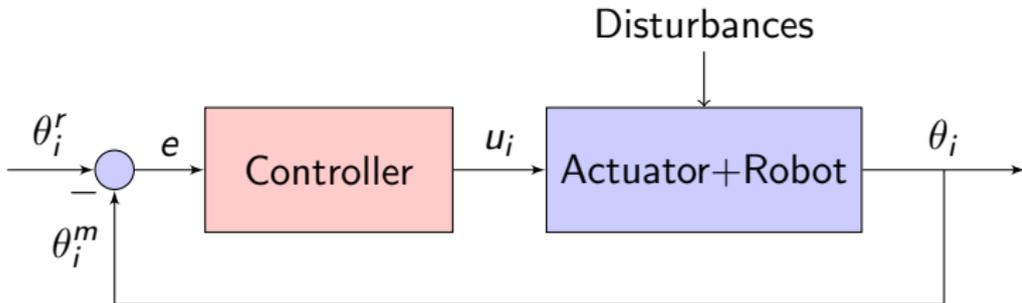

- Enables to force θ to follow the reference θ_r
- The actuator is usually a first (electric) or second order system (pneumatic)
- Usually controlled with a PID controller with
 - filtered derivative action



INNER CONTROL LOOP

Robotics

N. Marchand

Introduction

Outline

Mechanics

Kinematics

Arm robots
 Inner-loop
 Geometrical model
 Kinematic model
 Dynamical model
 Conclusion

Path planning

Workspace and obstacles
 path planning

Mobile robotics

Visual servoing

RX90 robot

- Inner control loop:

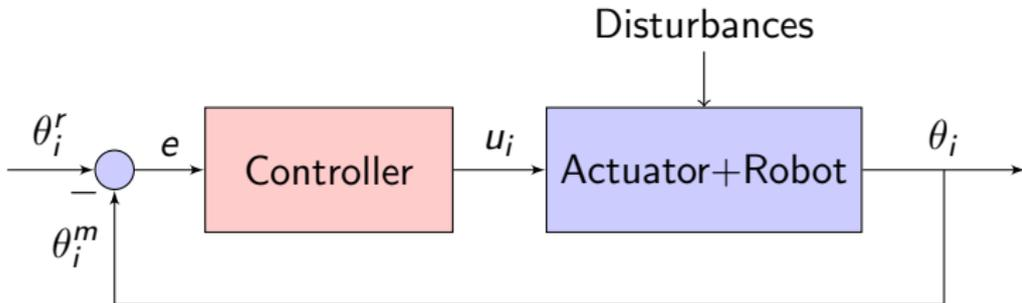

- Enables to force θ to follow the reference θ_r
- The actuator is usually a first (electric) or second order system (pneumatic)
- Usually controlled with a PID controller with
 - filtered derivative action
 - anti-windup to tackle saturations



INNER CONTROL LOOP

Anti-windup PID

Robotics

N. Marchand

Introduction

Outline

Mechanics

Kinematics

Arm robots
Inner-loop
Geometrical
model
Kinematic model
Dynamical
model
Conclusion

Path planning

Workspace and
obstacles
path planning

Mobile
robotics

Visual
servoing

RX90 robot

- We go back to the **X4** example and focus on the **rotors**:

$$\left\{ \dot{s}_i = -\frac{k_m^2}{J_r R} s_i - \frac{1}{J_r} \tau_{\text{load}} + \frac{k_m}{J_r R} \text{sat}_{\bar{U}_i}(U_i) \right.$$



INNER CONTROL LOOP

Anti-windup PID

Robotics

N. Marchand

Introduction

Outline

Mechanics

Kinematics

Arm robots

Inner-loop

Geometrical
model

Kinematic model

Dynamical
model

Conclusion

Path planning

Workspace and
obstacles
path planning

Mobile
robotics

Visual
servoing

RX90 robot

- We go back to the **X4** example and focus on the **rotors**:

$$\left\{ \dot{s}_i = -\frac{k_m^2}{J_r R} s_i - \frac{1}{J_r} \tau_{\text{load}} + \frac{k_m}{J_r R} \text{sat}_{\bar{U}_i}(U_i) \right.$$

- If one wants to **act on the X4 with desired forces** F_i^d , it is necessary to be able to **set the rotors speeds** s_i to s_i^d with

$$s_i^d = \sqrt{\frac{1}{b} F_i^d}$$



INNER CONTROL LOOP

Anti-windup PID

Robotics

N. Marchand

Introduction

Outline

Mechanics

Kinematics

Arm robots

Inner-loop

Geometrical
model

Kinematic model

Dynamical
model

Conclusion

Path planning

Workspace and
obstacles
path planning

Mobile
robotics

Visual
servoing

RX90 robot

- We go back to the **X4** example and focus on the **rotors**:

$$\left\{ \dot{s}_i = -\frac{k_m^2}{J_r R} s_i - \frac{1}{J_r} \tau_{\text{load}} + \frac{k_m}{J_r R} \text{sat}_{\bar{U}_i}(U_i) \right.$$

- If one wants to **act on the X4 with desired forces F_i^d** , it is necessary to be able to **set the rotors speeds s_i to s_i^d** with

$$s_i^d = \sqrt{\frac{1}{b} F_i^d}$$

- A usual way to control the electrical motor consist in



INNER CONTROL LOOP

Anti-windup PID

Robotics

N. Marchand

Introduction

Outline

Mechanics

Kinematics

Arm robots

Inner-loop

Geometrical
model

Kinematic model

Dynamical
model

Conclusion

Path planning

Workspace and
obstacles
path planning

Mobile
robotics

Visual
servoing

RX90 robot

- We go back to the **X4** example and focus on the **rotors**:

$$\begin{cases} \dot{s}_i = -\frac{k_m^2}{J_r R} s_i - \frac{1}{J_r} \tau_{\text{load}} + \frac{k_m}{J_r R} \text{sat}_{\bar{U}_i}(U_i) \end{cases}$$

- If one wants to **act on the X4 with desired forces** F_i^d , it is necessary to be able to **set the rotors speeds s_i to s_i^d** with

$$s_i^d = \sqrt{\frac{1}{b} F_i^d}$$

- A usual way to control the electrical motor consist in
 - taking τ_{load} **as an unknown load**



INNER CONTROL LOOP

Anti-windup PID

Robotics

N. Marchand

Introduction

Outline

Mechanics

Kinematics

Arm robots

Inner-loop

Geometrical
model

Kinematic model

Dynamical
model

Conclusion

Path planning

Workspace and
obstacles
path planningMobile
roboticsVisual
servoing

RX90 robot

- We go back to the **X4** example and focus on the **rotors**:

$$\begin{cases} \dot{s}_i = -\frac{k_m^2}{J_r R} s_i - \frac{1}{J_r} \tau_{\text{load}} + \frac{k_m}{J_r R} \text{sat}_{\bar{U}_i}(U_i) \end{cases}$$

- If one wants to **act on the X4 with desired forces F_i^d** , it is necessary to be able to **set the rotors speeds s_i to s_i^d** with

$$s_i^d = \sqrt{\frac{1}{b} F_i^d}$$

- A usual way to control the electrical motor consist in
 - taking τ_{load} **as an unknown load**
 - neglecting the voltage limitations \bar{U}_i**



INNER CONTROL LOOP

Anti-windup PID

Robotics

N. Marchand

- The so obtained **system is linear**

$$\frac{s_i(s)}{U_i(s)} = \frac{\frac{1}{k_m}}{1 + \frac{J_r R}{k_m^2} s} = \frac{G}{1 + \tau s}$$

Introduction

Outline

Mechanics

Kinematics

Arm robots

Inner-loop

Geometrical
model

Kinematic model

Dynamical
model

Conclusion

Path planning

Workspace and
obstacles

path planning

Mobile

robotics

Visual

servoing

RX90 robot



INNER CONTROL LOOP

Anti-windup PID

Robotics

N. Marchand

Introduction

Outline

Mechanics

Kinematics

Arm robots

Inner-loop

Geometrical
model

Kinematic model

Dynamical
model

Conclusion

Path planning

Workspace and
obstacles

path planning

Mobile

robotics

Visual

servoing

RX90 robot

- The so obtained **system is linear**

$$\frac{s_i(s)}{U_i(s)} = \frac{\frac{1}{k_m}}{1 + \frac{J_r R}{k_m^2} s} = \frac{G}{1 + \tau s}$$

- Define a **PI controller** for it:

$$C(s) = K_p + \frac{K_i}{s}$$



INNER CONTROL LOOP

Anti-windup PID

Robotics

N. Marchand

Introduction

Outline

Mechanics

Kinematics

Arm robots

Inner-loop

Geometrical
model

Kinematic model

Dynamical
model

Conclusion

Path planning

Workspace and
obstacles
path planningMobile
roboticsVisual
servoing

RX90 robot

- The so obtained **system is linear**

$$\frac{s_i(s)}{U_i(s)} = \frac{\frac{1}{k_m}}{1 + \frac{J_r R}{k_m^2} s} = \frac{G}{1 + \tau s}$$

- Define a **PI controller** for it:

$$C(s) = K_p + \frac{K_i}{s}$$

- Taking $K_i = \frac{1}{\tau_{CL} G}$ and $K_p = \tau K_i$, the closed loop system is:

$$\frac{s_i(s)}{U_i(s)} = \frac{1}{1 + \tau_{CL} s}$$

INNER CONTROL LOOP

Anti-windup PID

- Make a step that **compensates the weight**, that is such

that $s_i^d = \sqrt{\frac{mg}{4b}}$ so that $\sum_i F_i^d = mg$

Robotics

N. Marchand

Introduction

Outline

Mechanics

Kinematics

Arm robots
Inner-loop
Geometrical model
Kinematic model
Dynamical model
Conclusion

Path planning

Workspace and obstacles
path planning

Mobile robotics

Visual servoing

RX90 robot



INNER CONTROL LOOP

Anti-windup PID

Robotics

N. Marchand

Introduction

Outline

Mechanics

Kinematics

Arm robots

Inner-loop

Geometrical
model

Kinematic model

Dynamical
model

Conclusion

Path planning

Workspace and
obstacles
path planning

Mobile
robotics

Visual
servoing

RX90 robot

- Make a step that **compensates the weight**, that is such that $s_i^d = \sqrt{\frac{mg}{4b}}$ so that $\sum_i F_i^d = mg$
- Taking $\tau_{CL} = 50$ ms, one gets **without saturations**

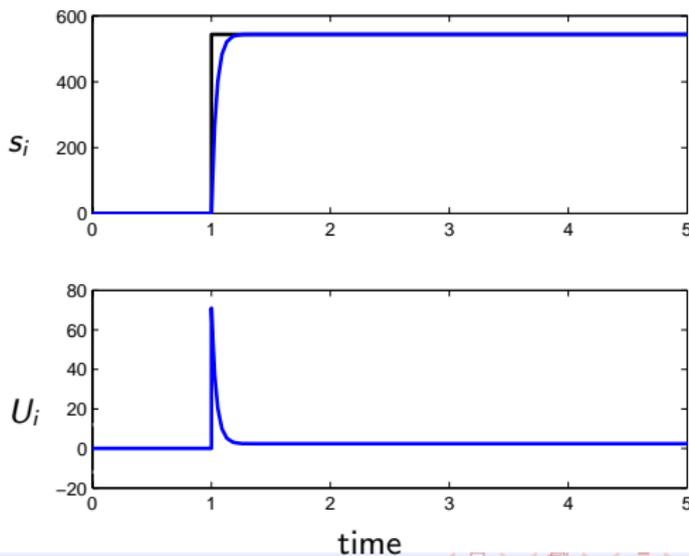



INNER CONTROL LOOP

Anti-windup PID

Robotics

N. Marchand

Introduction

Outline

Mechanics

Kinematics

Arm robots

Inner-loop

Geometrical
model

Kinematic model

Dynamical
model

Conclusion

Path planning

Workspace and
obstacles
path planning

Mobile
robotics

Visual
servoing

RX90 robot

- Make a step that **compensates the weight**, that is such that $s_i^d = \sqrt{\frac{mg}{4b}}$ so that $\sum_i F_i^d = mg$
- Taking $\tau_{CL} = 50$ ms, one gets **with saturations**

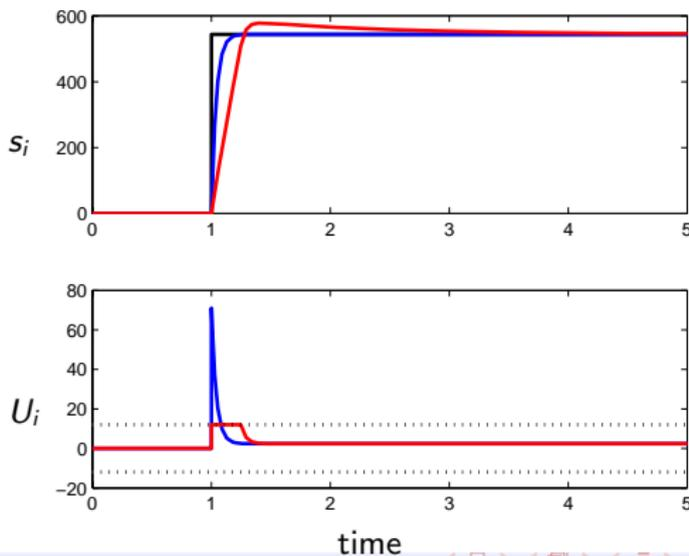



INNER CONTROL LOOP

Anti-windup PID

- The result could be worse:

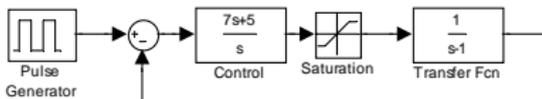

Robotics

N. Marchand

Introduction

Outline

Mechanics

Kinematics

Arm robots

Inner-loop

Geometrical
model

Kinematic model

Dynamical
model

Conclusion

Path planning

Workspace and
obstacles

path planning

Mobile
robotics

Visual
servoing

RX90 robot



INNER CONTROL LOOP

Anti-windup PID

Robotics

N. Marchand

Introduction

Outline

Mechanics

Kinematics

Arm robots

Inner-loop

Geometrical
model

Kinematic model

Dynamical
model

Conclusion

Path planning

Workspace and
obstacles
path planning

Mobile
robotics

Visual
servoing

RX90 robot

- The result could be worse:

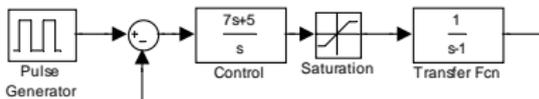

- For $u \in [-1.2, 1.2]$, the closed-loop behavior is:

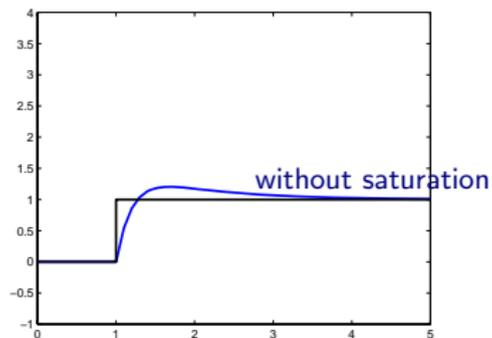



INNER CONTROL LOOP

Anti-windup PID

Robotics

N. Marchand

Introduction

Outline

Mechanics

Kinematics

Arm robots

Inner-loop

Geometrical
model

Kinematic model

Dynamical
model

Conclusion

Path planning

Workspace and
obstacles
path planning

Mobile
robotics

Visual
servoing

RX90 robot

- The result could be worse:

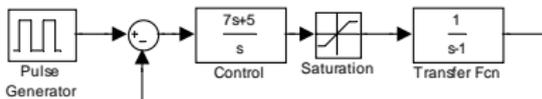

- For $u \in [-1.2, 1.2]$, the closed-loop behavior is:

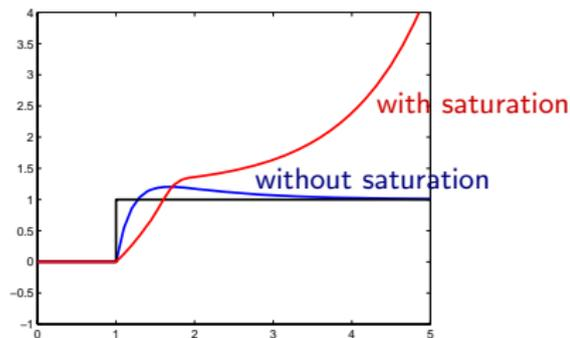



INNER CONTROL LOOP

Anti-windup PID

Robotics

N. Marchand

Introduction

Outline

Mechanics

Kinematics

Arm robots

Inner-loop

Geometrical
model

Kinematic model

Dynamical
model

Conclusion

Path planning

Workspace and
obstacles
path planning

Mobile
robotics

Visual
servoing

RX90 robot

- The result could be worse:

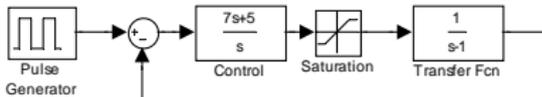

- For $u \in [-1.2, 1.2]$, the closed-loop behavior is:

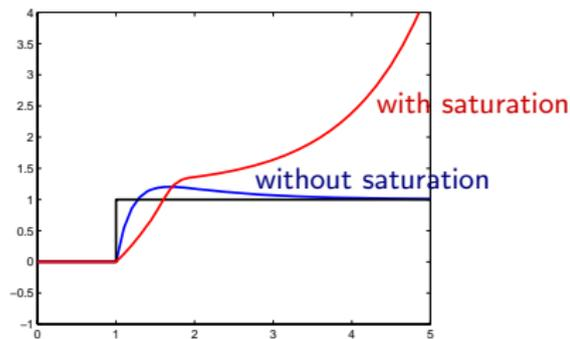

- Saturations may lead to instability** especially in the presence of integrators in the loop



INNER CONTROL LOOP

Anti-windup PID

Robotics

N. Marchand

Introduction

Outline

Mechanics

Kinematics

Arm robots

Inner-loop

Geometrical
model

Kinematic model

Dynamical
model

Conclusion

Path planning

Workspace and
obstacles

path planning

Mobile

robotics

Visual

servoing

RX90 robot

- Consider a **linear system with a PID** controller:

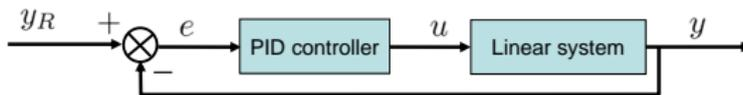



INNER CONTROL LOOP

Anti-windup PID

Robotics

N. Marchand

- Consider a **linear system with a PID** controller:

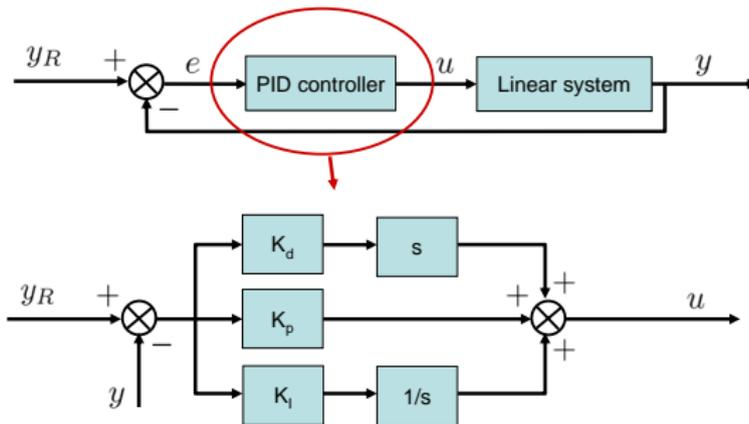

Introduction

Outline

Mechanics

Kinematics

Arm robots

Inner-loop

Geometrical model

Kinematic model

Dynamical model

Conclusion

Path planning

Workspace and obstacles

path planning

Mobile

robotics

Visual

servoing

RX90 robot

INNER CONTROL LOOP

Anti-windup PID

Robotics

N. Marchand

Introduction

Outline

Mechanics

Kinematics

Arm robots

Inner-loop

Geometrical model

Kinematic model

Dynamical model

Conclusion

Path planning

Workspace and obstacles
path planning

Mobile robotics

Visual servoing

RX90 robot

- Consider a **linear system with a PID** controller:

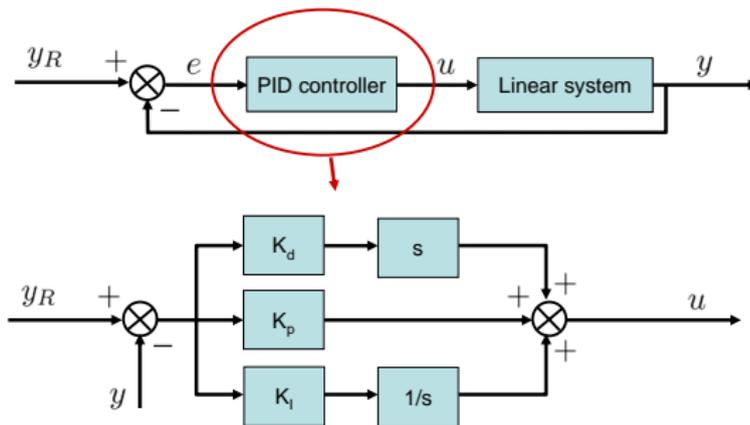

- The instability comes from the **integration** of the error

INNER CONTROL LOOP

Anti-windup PID

Robotics

N. Marchand

Introduction

Outline

Mechanics

Kinematics

Arm robots

Inner-loop

Geometrical model

Kinematic model

Dynamical model

Conclusion

Path planning

Workspace and obstacles
path planning

Mobile robotics

Visual servoing

RX90 robot

- Consider a **linear system with a PID** controller:

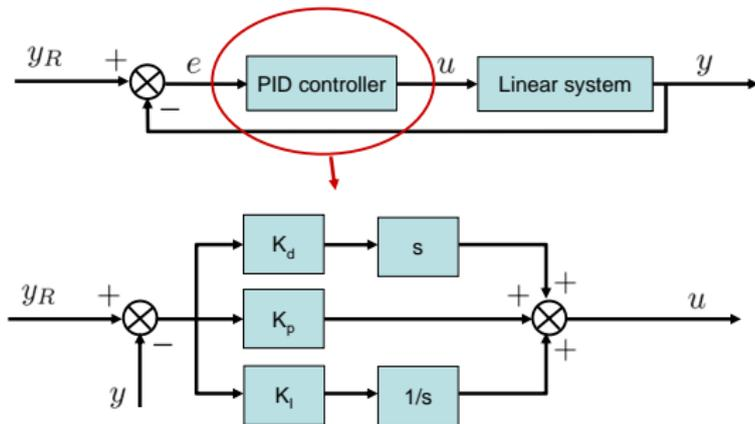

- The instability comes from the **integration** of the error
- Key idea:** soften the integral effect when the control is saturated



INNER CONTROL LOOP

Anti-windup PID

- Structure of the **PID controller with anti-windup**:

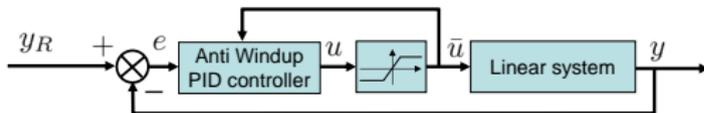

Robotics

N. Marchand

Introduction

Outline

Mechanics

Kinematics

- Arm robots
- Inner-loop**
- Geometrical model
- Kinematic model
- Dynamical model
- Conclusion

Path planning

- Workspace and obstacles
- path planning

- Mobile robotics

- Visual servoing

- RX90 robot



INNER CONTROL LOOP

Anti-windup PID

Robotics

N. Marchand

- Structure of the **PID controller with anti-windup**:

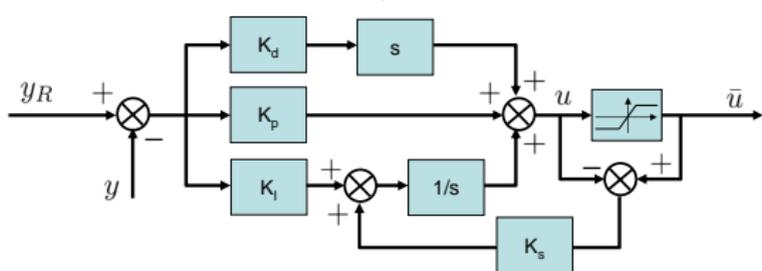
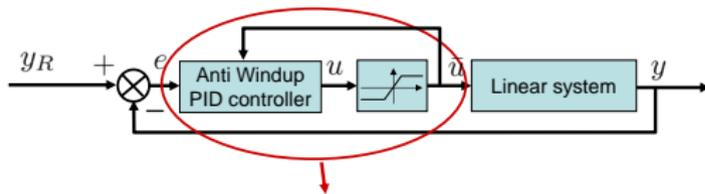

Introduction

Outline

Mechanics

Kinematics

Arm robots

Inner-loop

Geometrical model

Kinematic model

Dynamical model

Conclusion

Path planning

Workspace and obstacles

path planning

Mobile robotics

Visual servoing

RX90 robot



INNER CONTROL LOOP

Anti-windup PID

Robotics

N. Marchand

Introduction

Outline

Mechanics

Kinematics

Arm robots

Inner-loop

Geometrical
model

Kinematic model

Dynamical
model

Conclusion

Path planning

Workspace and
obstacles
path planningMobile
roboticsVisual
servoing

RX90 robot

- Structure of the **PID controller with anti-windup**:

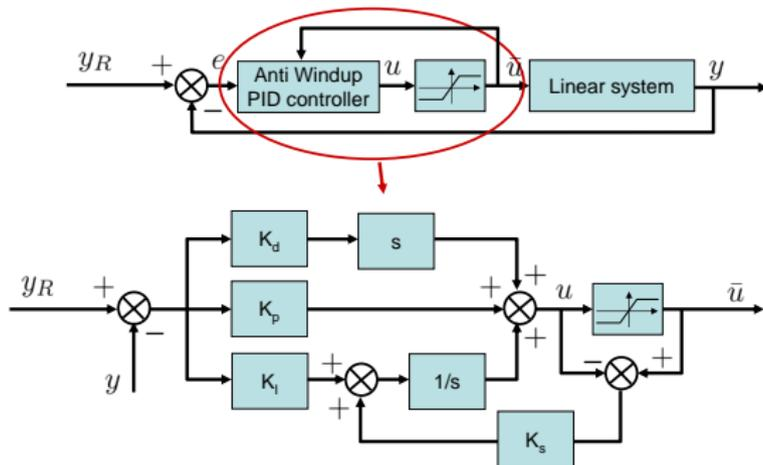

- If $u = \bar{u}$, that is if u is not saturated, **then the PID controller with anti-windup is identical to the classical PID controller**

INNER CONTROL LOOP

Anti-windup PID

Robotics

N. Marchand

Introduction

Outline

Mechanics

Kinematics

Arm robots

Inner-loop

Geometrical
model

Kinematic model

Dynamical
model

Conclusion

Path planning

Workspace and
obstacles
path planningMobile
roboticsVisual
servoing

RX90 robot

- Structure of the **PID controller with anti-windup**:

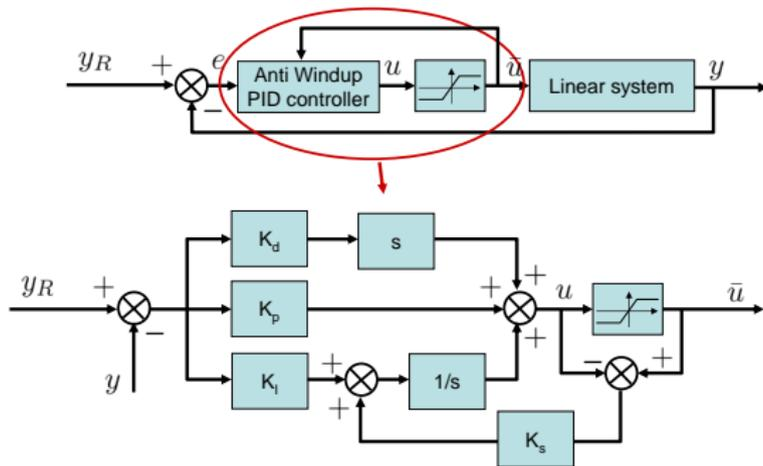

- If $u = \bar{u}$, that is if u is not saturated, **then the PID controller with anti-windup is identical to the classical PID controller**
- If u is saturated ($u \neq \bar{u}$), K_s tunes the reduction of the **integral effect** of the PID

INNER CONTROL LOOP

Anti-windup PID

- Make a step that **compensates the weight**, that is such

that $s_i^d = \sqrt{\frac{mg}{4b}}$ so that $\sum_i F_i^d = mg$

Robotics

N. Marchand

Introduction

Outline

Mechanics

Kinematics

Arm robots
Inner-loop
Geometrical model
Kinematic model
Dynamical model
Conclusion

Path planning

Workspace and obstacles
path planning

Mobile robotics

Visual servoing

RX90 robot



INNER CONTROL LOOP

Anti-windup PID

Robotics

N. Marchand

Introduction

Outline

Mechanics

Kinematics

Arm robots

Inner-loop

Geometrical
model

Kinematic model

Dynamical
model

Conclusion

Path planning

Workspace and
obstacles
path planning

Mobile
robotics

Visual
servoing

RX90 robot

- Make a step that **compensates the weight**, that is such that $s_i^d = \sqrt{\frac{mg}{4b}}$ so that $\sum_i F_i^d = mg$
- Taking $\tau_{CL} = 50$ ms, one gets **without anti-windup**

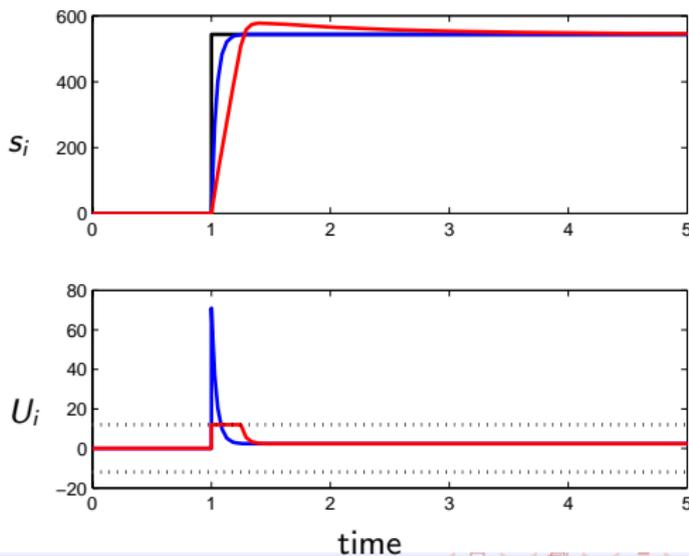

INNER CONTROL LOOP

Anti-windup PID

Robotics

N. Marchand

Introduction

Outline

Mechanics

Kinematics

- Arm robots
- Inner-loop**
- Geometrical model
- Kinematic model
- Dynamical model
- Conclusion

Path planning

- Workspace and obstacles
- path planning

Mobile robotics

Visual servoing

RX90 robot

- Make a step that **compensates the weight**, that is such that $s_i^d = \sqrt{\frac{mg}{4b}}$ so that $\sum_i F_i^d = mg$
- Taking $\tau_{CL} = 50$ ms, one gets **with anti-windup**

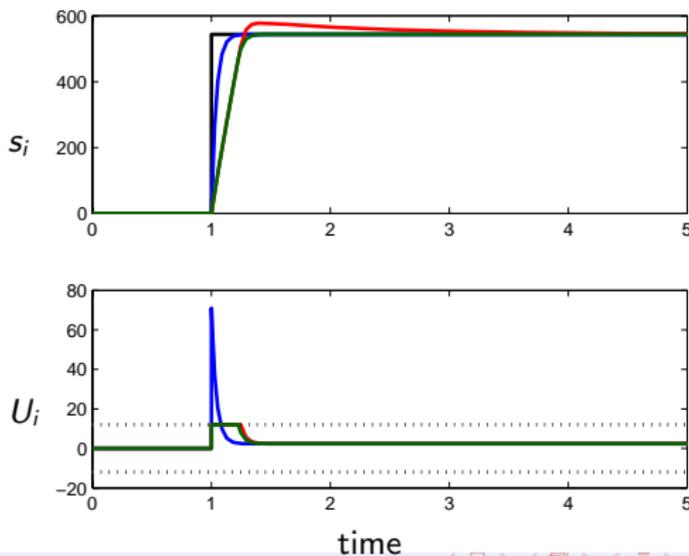



INNER CONTROL LOOP

Towards gain scheduling

- Take again $\tau_{CL} = 50$ ms and a **PI controller tuned at s_i^d**

Robotics

N. Marchand

Introduction

Outline

Mechanics

Kinematics

Arm robots
Inner-loop
Geometrical
model
Kinematic model
Dynamical
model
Conclusion

Path planning

Workspace and
obstacles
path planning

Mobile
robotics

Visual
servoing

RX90 robot



INNER CONTROL LOOP

Towards gain scheduling

- Take again $\tau_{CL} = 50$ ms and a **PI controller tuned at s_i^d**
- Make speed steps of different level

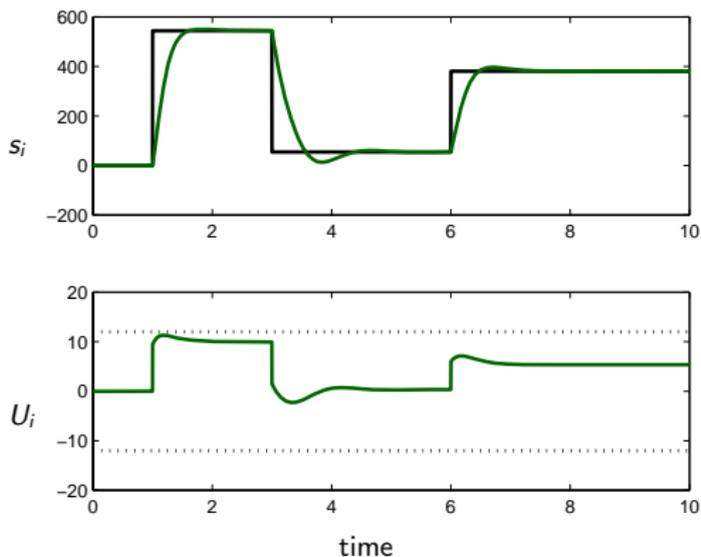

Robotics

N. Marchand

Introduction

Outline

Mechanics

Kinematics

Arm robots

Inner-loop

Geometrical
model

Kinematic model

Dynamical
model

Conclusion

Path planning

Workspace and
obstacles
path planning

Mobile
robotics

Visual
servoing

RX90 robot



INNER CONTROL LOOP

Towards gain scheduling

Robotics

N. Marchand

Introduction

Outline

Mechanics

Kinematics

Arm robots

Inner-loop

Geometrical
model

Kinematic model

Dynamical
model

Conclusion

Path planning

Workspace and
obstacles
path planning

Mobile
robotics

Visual
servoing

RX90 robot

- Take again $\tau_{CL} = 50$ ms and a **PI controller tuned at s_i^d**
- Make speed steps of different level

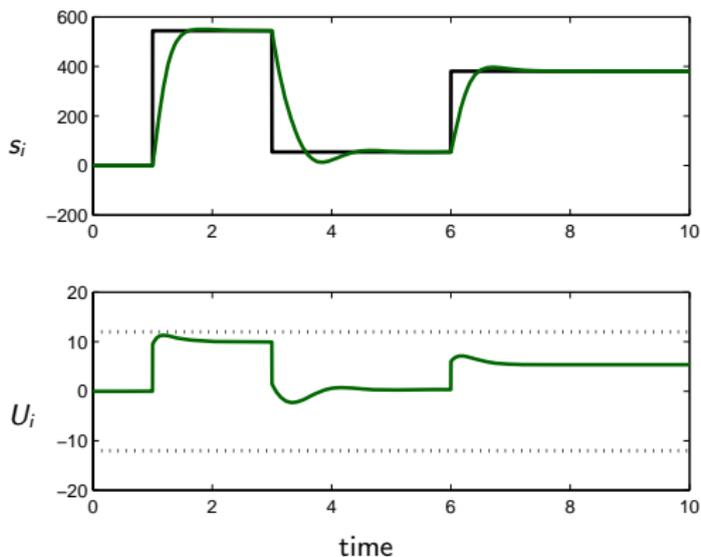

- The controller is well tuned near s_i^d but **not very good a large range of use**



INNER CONTROL LOOP

Towards gain scheduling

- Take again $\tau_{CL} = 50$ ms and a **PI controller tuned at the current s_i**

Robotics

N. Marchand

Introduction

Outline

Mechanics

Kinematics

Arm robots
Inner-loop
Geometrical
model
Kinematic model
Dynamical
model
Conclusion

Path planning

Workspace and
obstacles
path planning

Mobile
robotics

Visual
servoing

RX90 robot



INNER CONTROL LOOP

Towards gain scheduling

- Take again $\tau_{CL} = 50 \text{ ms}$ and a **PI controller tuned at the current s_i**
- Make speed steps of different level

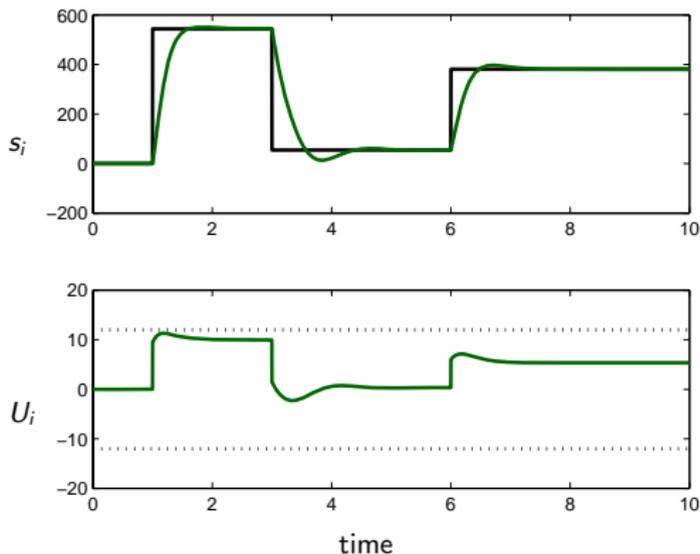



INNER CONTROL LOOP

Towards gain scheduling

- Take again $\tau_{CL} = 50$ ms and a **PI controller tuned at the current s_i**
- Make speed steps of different level

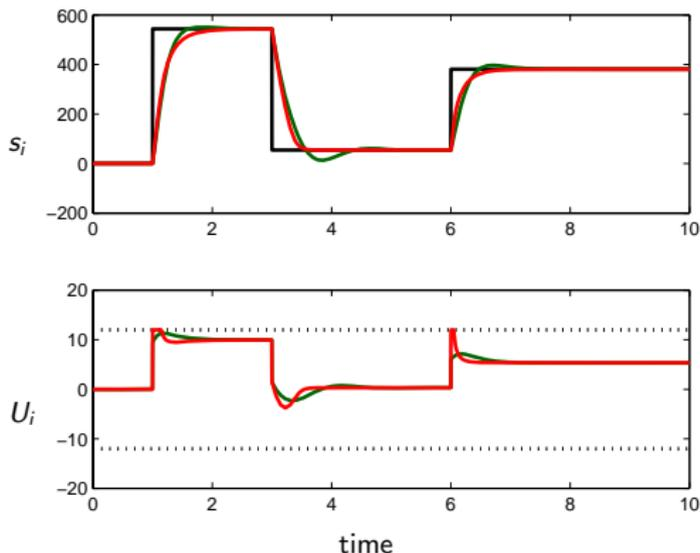

- **The rotors are now well controlled**

Robotics

N. Marchand

Introduction

Outline

Mechanics

Kinematics

Arm robots

Inner-loop

Geometrical model

Kinematic model

Dynamical model

Conclusion

Path planning

Workspace and obstacles

path planning

Mobile robotics

Visual servoing

RX90 robot

- 1 Introduction
- 2 Outline
- 3 Mechanics basis
- 4 Kinematics and dynamics of robots**
 - Arm robots
 - Inner-loop
 - Geometrical model**
 - Kinematic model
 - Dynamical model
 - Conclusion
- 5 Path planning
 - Workspace and obstacles
 - Path planning problem formulation
- 6 Mobile robotics
- 7 Visual servoing
- 8 Stäubli RX90 robot

JOINTED-ARM ROBOTS

Robotics

N. Marchand

Introduction

Outline

Mechanics

Kinematics

Arm robots

Inner-loop

**Geometrical
model**

Kinematic model

Dynamical
model

Conclusion

Path planning

Workspace and
obstacles

path planning

Mobile
robotics

Visual
servoing

RX90 robot

- Characteristic variables:



JOINTED-ARM ROBOTS

Robotics

N. Marchand

Introduction

Outline

Mechanics

Kinematics

Arm robots

Inner-loop

**Geometrical
model**

Kinematic model

Dynamical
model

Conclusion

Path planning

Workspace and
obstacles

path planning

Mobile
robotics

Visual
servoing

RX90 robot

- Characteristic variables:
 - Actuator control u_i

JOINTED-ARM ROBOTS

Robotics

N. Marchand

Introduction

Outline

Mechanics

Kinematics

Arm robots

Inner-loop

Geometrical
model

Kinematic model

Dynamical
model

Conclusion

Path planning

Workspace and
obstacles

path planning

Mobile
robotics

Visual
servoing

RX90 robot

- Characteristic variables:
 - Actuator control u_i
 - Actuator torques C_i

Robotics

N. Marchand

Introduction

Outline

Mechanics

Kinematics

Arm robots

Inner-loop

Geometrical
model

Kinematic model

Dynamical
model

Conclusion

Path planning

Workspace and
obstacles

path planning

Mobile

robotics

Visual

servoing

RX90 robot

- Characteristic variables:
 - Actuator control u_i
 - Actuator torques C_i
 - Angles θ_i

JOINTED-ARM ROBOTS

Robotics

N. Marchand

Introduction

Outline

Mechanics

Kinematics

Arm robots

Inner-loop

Geometrical
model

Kinematic model

Dynamical
model

Conclusion

Path planning

Workspace and
obstacles

path planning

Mobile

robotics

Visual

servoing

RX90 robot

- Characteristic variables:
 - Actuator control u_i
 - Actuator torques C_i
 - Angles θ_i
 - Spatial position X_i

JOINTED-ARM ROBOTS

Robotics

N. Marchand

Introduction

Outline

Mechanics

Kinematics

Arm robots

Inner-loop

Geometrical
model

Kinematic model

Dynamical
model

Conclusion

Path planning

Workspace and
obstacles

path planning

Mobile
robotics

Visual
servoing

RX90 robot

- Characteristic variables:
 - Actuator control u_i
 - Actuator torques C_i
 - Angles θ_i
 - Spatial position X_i
- Controlling a robot is equivalent to mastering the relation

$$u_i \Leftrightarrow C_i \Leftrightarrow \theta_i \Leftrightarrow X_i$$

JOINTED-ARM ROBOTS

Robotics

N. Marchand

Introduction

Outline

Mechanics

Kinematics

Arm robots

Inner-loop

Geometrical
model

Kinematic model

Dynamical
model

Conclusion

Path planning

Workspace and
obstacles

path planning

Mobile
robotics

Visual
servoing

RX90 robot

- Characteristic variables:
 - Actuator control u_i
 - Actuator torques C_i
 - Angles θ_i
 - Spatial position X_i
- Controlling a robot is equivalent to mastering the relation

$$u_i \Leftrightarrow C_i \Leftrightarrow \theta_i \Leftrightarrow X_i$$

- Actuator dynamics 

JOINTED-ARM ROBOTS

Robotics

N. Marchand

Introduction

Outline

Mechanics

Kinematics

Arm robots

Inner-loop

Geometrical
model

Kinematic model

Dynamical
model

Conclusion

Path planning

Workspace and
obstacles

path planning

Mobile robotics

Visual servoing

RX90 robot

- Characteristic variables:
 - Actuator control u_i
 - Actuator torques C_i
 - Angles θ_i
 - Spatial position X_i
- Controlling a robot is equivalent to mastering the relation

$$u_i \Leftrightarrow C_i \Leftrightarrow \theta_i \Leftrightarrow X_i$$

- Actuator dynamics 
- Robot dynamics 

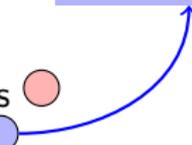

GEOMETRICAL MODEL OF ROBOTS

Robotics

- Consist in finding the relations $X_i = f_i(\theta_i)$

N. Marchand

Introduction

Outline

Mechanics

Kinematics

Arm robots

Inner-loop

**Geometrical
model**

Kinematic model

Dynamical
model

Conclusion

Path planning

Workspace and
obstacles

path planning

Mobile
robotics

Visual
servoing

RX90 robot

GEOMETRICAL MODEL OF ROBOTS

Robotics

- Consist in finding the relations $X_i = f_i(\theta_i)$
- Sometimes called “forward kinematics”

N. Marchand

Introduction

Outline

Mechanics

Kinematics

Arm robots

Inner-loop

**Geometrical
model**

Kinematic model

Dynamical
model

Conclusion

Path planning

Workspace and
obstacles

path planning

Mobile
robotics

Visual
servoing

RX90 robot



GEOMETRICAL MODEL OF ROBOTS

Robotics

N. Marchand

Introduction

Outline

Mechanics

Kinematics

Arm robots

Inner-loop

**Geometrical
model**

Kinematic model

Dynamical
model

Conclusion

Path planning

Workspace and
obstacles

path planning

Mobile
robotics

Visual
servoing

RX90 robot

- Consist in finding the relations $X_i = f_i(\theta_i)$
- Sometimes called “forward kinematics”
- That gives $X_n = f(\theta_1, \dots, \theta_n)$, the position of the extremity of the arm as a functions of the control angles (and of the robot parameters)



GEOMETRICAL MODEL OF ROBOTS

Robotics

N. Marchand

Introduction

Outline

Mechanics

Kinematics

Arm robots

Inner-loop

**Geometrical
model**

Kinematic model

Dynamical
model

Conclusion

Path planning

Workspace and
obstacles

path planning

Mobile robotics

Visual servoing

RX90 robot

- Consist in finding the relations $X_i = f_i(\theta_i)$
- Sometimes called “forward kinematics”
- That gives $X_n = f(\theta_1, \dots, \theta_n)$, the position of the extremity of the arm as a functions of the control angles (and of the robot parameters)
- The aim is then to deduce the θ_i^r 's using f^{-1} (inversion)



GEOMETRICAL MODEL OF ROBOTS

Robotics

N. Marchand

Introduction

Outline

Mechanics

Kinematics

Arm robots

Inner-loop

**Geometrical
model**

Kinematic model

Dynamical
model

Conclusion

Path planning

Workspace and
obstacles

path planning

Mobile robotics

Visual servoing

RX90 robot

- Consist in finding the relations $X_i = f_i(\theta_i)$
- Sometimes called “forward kinematics”
- That gives $X_n = f(\theta_1, \dots, \theta_n)$, the position of the extremity of the arm as a functions of the control angles (and of the robot parameters)
- The aim is then to deduce the θ_i^r 's using f^{-1} (inversion)
- Assumptions:



GEOMETRICAL MODEL OF ROBOTS

Robotics

N. Marchand

Introduction

Outline

Mechanics

Kinematics

Arm robots
Inner-loop

Geometrical model

Kinematic model
Dynamical model
Conclusion

Path planning

Workspace and obstacles
path planning

Mobile robotics

Visual servoing

RX90 robot

- Consist in finding the relations $X_i = f_i(\theta_i)$
- Sometimes called “forward kinematics”
- That gives $X_n = f(\theta_1, \dots, \theta_n)$, the position of the extremity of the arm as a functions of the control angles (and of the robot parameters)
- The aim is then to deduce the θ_i^r 's using f^{-1} (inversion)
- Assumptions:
 - The model must be quite **precise**



GEOMETRICAL MODEL OF ROBOTS

Robotics

N. Marchand

Introduction

Outline

Mechanics

Kinematics

Arm robots

Inner-loop

Geometrical
model

Kinematic model

Dynamical
model

Conclusion

Path planning

Workspace and
obstacles

path planning

Mobile

robotics

Visual

servoing

RX90 robot

- Consist in finding the relations $X_i = f_i(\theta_i)$
- Sometimes called “forward kinematics”
- That gives $X_n = f(\theta_1, \dots, \theta_n)$, the position of the extremity of the arm as a functions of the control angles (and of the robot parameters)
- The aim is then to deduce the θ_i^r 's using f^{-1} (inversion)
- Assumptions:
 - The model must be quite **precise**
 - no friction, no drift, no backlash, no dead zone, ...



GEOMETRICAL MODEL OF ROBOTS

Robotics

N. Marchand

Introduction

Outline

Mechanics

Kinematics

Arm robots
Inner-loop

Geometrical model

Kinematic model

Dynamical model

Conclusion

Path planning

Workspace and obstacles
path planning

Mobile robotics

Visual servoing

RX90 robot

- Consist in finding the relations $X_i = f_i(\theta_i)$
- Sometimes called “forward kinematics”
- That gives $X_n = f(\theta_1, \dots, \theta_n)$, the position of the extremity of the arm as a functions of the control angles (and of the robot parameters)
- The aim is then to deduce the θ_i^r 's using f^{-1} (inversion)
- Assumptions:
 - The model must be quite **precise**
 - no friction, no drift, no backlash, no dead zone, ...
 - The **dynamical phenomena must be negligible**



GEOMETRICAL MODEL OF ROBOTS

Robotics

N. Marchand

Introduction

Outline

Mechanics

Kinematics

Arm robots

Inner-loop

Geometrical
model

Kinematic model

Dynamical
model

Conclusion

Path planning

Workspace and
obstacles

path planning

Mobile

robotics

Visual

servoing

RX90 robot

- Consist in finding the relations $X_i = f_i(\theta_i)$
- Sometimes called “forward kinematics”
- That gives $X_n = f(\theta_1, \dots, \theta_n)$, the position of the extremity of the arm as a functions of the control angles (and of the robot parameters)
- The aim is then to deduce the θ_i^r 's using f^{-1} (inversion)
- Assumptions:
 - The model must be quite **precise**
 - no friction, no drift, no backlash, no dead zone, ...
 - The **dynamical phenomena must be negligible**
 - mass effect fully compensated by the inner-loop



GEOMETRICAL MODEL OF ROBOTS

Robotics

N. Marchand

Introduction

Outline

Mechanics

Kinematics

Arm robots
Inner-loop

Geometrical
model

Kinematic model

Dynamical
model

Conclusion

Path planning

Workspace and
obstacles
path planning

Mobile
robotics

Visual
servoing

RX90 robot

- Consist in finding the relations $X_i = f_i(\theta_i)$
- Sometimes called “forward kinematics”
- That gives $X_n = f(\theta_1, \dots, \theta_n)$, the position of the extremity of the arm as a functions of the control angles (and of the robot parameters)
- The aim is then to deduce the θ_i^r 's using f^{-1} (inversion)
- Assumptions:
 - The model must be quite **precise**
 - no friction, no drift, no backlash, no dead zone, ...
 - The **dynamical phenomena must be negligible**
 - mass effect fully compensated by the inner-loop
 - few flexibility of the arms (not for spatial robotic arms !)



GEOMETRICAL MODEL OF ROBOTS

Robotics

N. Marchand

Introduction

Outline

Mechanics

Kinematics

Arm robots

Inner-loop

Geometrical
model

Kinematic model

Dynamical
model

Conclusion

Path planning

Workspace and
obstacles

path planning

Mobile

robotics

Visual

servoing

RX90 robot

- Consist in finding the relations $X_i = f_i(\theta_i)$
- Sometimes called “forward kinematics”
- That gives $X_n = f(\theta_1, \dots, \theta_n)$, the position of the extremity of the arm as a functions of the control angles (and of the robot parameters)
- The aim is then to deduce the θ_i^r 's using f^{-1} (inversion)
- Assumptions:
 - The model must be quite **precise**
 - no friction, no drift, no backlash, no dead zone, ...
 - The **dynamical phenomena must be negligible**
 - mass effect fully compensated by the inner-loop
 - few flexibility of the arms (not for spatial robotic arms !)
 - Sufficiently simple model to be online inverted



GEOMETRICAL MODEL OF ROBOTS

Robotics

N. Marchand

Introduction

Outline

Mechanics

Kinematics

Arm robots

Inner-loop

Geometrical
model

Kinematic model

Dynamical
model

Conclusion

Path planning

Workspace and
obstacles

path planning

Mobile

robotics

Visual

servoing

RX90 robot

- Consist in finding the relations $X_i = f_i(\theta_i)$
- Sometimes called “forward kinematics”
- That gives $X_n = f(\theta_1, \dots, \theta_n)$, the position of the extremity of the arm as a functions of the control angles (and of the robot parameters)
- The aim is then to deduce the θ_i^r 's using f^{-1} (inversion)
- Assumptions:
 - The model must be quite **precise**
 - no friction, no drift, no backlash, no dead zone, ...
 - The **dynamical phenomena must be negligible**
 - mass effect fully compensated by the inner-loop
 - few flexibility of the arms (not for spatial robotic arms !)
 - Sufficiently simple model to be online inverted
 - The model must be **invertible**



GEOMETRICAL MODEL OF ROBOTS

Robotics

N. Marchand

Introduction

Outline

Mechanics

Kinematics

Arm robots
Inner-loop

Geometrical
model

Kinematic model

Dynamical
model

Conclusion

Path planning

Workspace and
obstacles
path planning

Mobile
robotics

Visual
servoing

RX90 robot

- Consist in finding the relations $X_i = f_i(\theta_i)$
- Sometimes called “forward kinematics”
- That gives $X_n = f(\theta_1, \dots, \theta_n)$, the position of the extremity of the arm as a functions of the control angles (and of the robot parameters)
- The aim is then to deduce the θ_i^r 's using f^{-1} (inversion)
- Assumptions:
 - The model must be quite **precise**
 - no friction, no drift, no backlash, no dead zone, ...
 - The **dynamical phenomena must be negligible**
 - mass effect fully compensated by the inner-loop
 - few flexibility of the arms (not for spatial robotic arms !)
 - Sufficiently simple model to be online inverted
 - The model must be **invertible**
- Despite the limitations, this approach is widely used (oversized robots)



COMPUTATION OF THE GEOMETRICAL MODEL

Combination of rotations and translations

Robotics

N. Marchand

Introduction

Outline

Mechanics

Kinematics

Arm robots

Inner-loop

Geometrical
model

Kinematic model

Dynamical
model

Conclusion

Path planning

Workspace and
obstacles

path planning

Mobile
robotics

Visual
servoing

RX90 robot

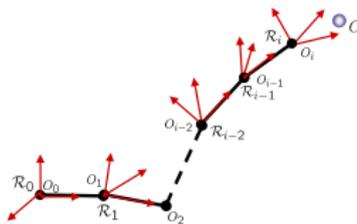

- Let X be the orientation and position of the last segment in \mathcal{R}_0 (usually variable to control)

COMPUTATION OF THE GEOMETRICAL MODEL

Combination of rotations and translations

Robotics

N. Marchand

Introduction

Outline

Mechanics

Kinematics

Arm robots

Inner-loop

Geometrical model

Kinematic model

Dynamical model

Conclusion

Path planning

Workspace and obstacles

path planning

Mobile robotics

Visual servoing

RX90 robot

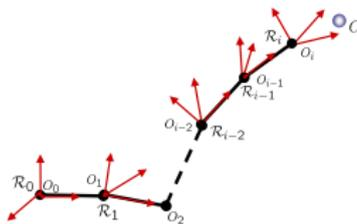

- Let X be the orientation and position of the last segment in \mathcal{R}_0 (usually variable to control)
- **Orientation:** for any \vec{v}



COMPUTATION OF THE GEOMETRICAL MODEL

Combination of rotations and translations

Robotics

N. Marchand

Introduction

Outline

Mechanics

Kinematics

Arm robots

Inner-loop

Geometrical
model

Kinematic model

Dynamical
model

Conclusion

Path planning

Workspace and
obstacles

path planning

Mobile
robotics

Visual
servoing

RX90 robot

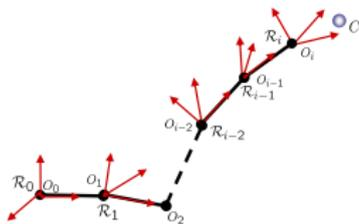

- Let X be the orientation and position of the last segment in \mathcal{R}_0 (usually variable to control)
- **Orientation:** for any \vec{v}
 - $\vec{v}(\mathcal{R}_i) = R_{i-1}^i \vec{v}(\mathcal{R}_{i-1})$



COMPUTATION OF THE GEOMETRICAL MODEL

Combination of rotations and translations

Robotics

N. Marchand

Introduction

Outline

Mechanics

Kinematics

Arm robots

Inner-loop

Geometrical
model

Kinematic model

Dynamical
model

Conclusion

Path planning

Workspace and
obstacles

path planning

Mobile

robotics

Visual

servoing

RX90 robot

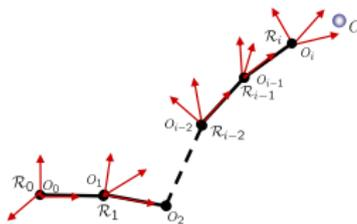

- Let X be the orientation and position of the last segment in \mathcal{R}_0 (usually variable to control)
- **Orientation:** for any \vec{v}
 - $\vec{v}(\mathcal{R}_i) = R_{i-1}^i \vec{v}(\mathcal{R}_{i-1})$
 - $\vec{v}(\mathcal{R}_i) = \prod_{k=1}^i R_{k-1}^k \vec{v}(\mathcal{R}_0) = R_0^i \vec{v}(\mathcal{R}_0)$



COMPUTATION OF THE GEOMETRICAL MODEL

Combination of rotations and translations

Robotics

N. Marchand

Introduction

Outline

Mechanics

Kinematics

Arm robots

Inner-loop

Geometrical
model

Kinematic model

Dynamical
model

Conclusion

Path planning

Workspace and
obstacles

path planning

Mobile
robotics

Visual
servoing

RX90 robot

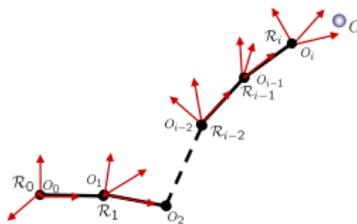

- Let X be the orientation and position of the last segment in \mathcal{R}_0 (usually variable to control)
- **Orientation:** for any \vec{v}
 - $\vec{v}(\mathcal{R}_i) = R_{i-1}^i \vec{v}(\mathcal{R}_{i-1})$
 - $\vec{v}(\mathcal{R}_i) = \prod_{k=1}^i R_{k-1}^k \vec{v}(\mathcal{R}_0) = R_0^i \vec{v}(\mathcal{R}_0)$
- **Position:** for any point C



COMPUTATION OF THE GEOMETRICAL MODEL

Combination of rotations and translations

Robotics

N. Marchand

Introduction

Outline

Mechanics

Kinematics

Arm robots

Inner-loop

Geometrical
model

Kinematic model

Dynamical
model

Conclusion

Path planning

Workspace and
obstacles

path planning

Mobile
robotics

Visual
servoing

RX90 robot

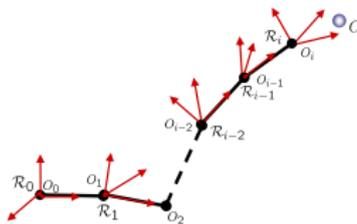

- Let X be the orientation and position of the last segment in \mathcal{R}_0 (usually variable to control)
- **Orientation:** for any \vec{v}
 - $\vec{v}(\mathcal{R}_i) = R_{i-1}^i \vec{v}(\mathcal{R}_{i-1})$
 - $\vec{v}(\mathcal{R}_i) = \prod_{k=1}^i R_{k-1}^k \vec{v}(\mathcal{R}_0) = R_0^i \vec{v}(\mathcal{R}_0)$
- **Position:** for any point C
 - $\overline{O_0} \vec{c}(\mathcal{R}_0) = \overline{O_0} \vec{O}_i(\mathcal{R}_0) + \overline{O_i} \vec{c}(\mathcal{R}_0) = \overline{O_0} \vec{O}_i(\mathcal{R}_0) + R_i^0 \overline{O_i} \vec{c}(\mathcal{R}_i)$



COMPUTATION OF THE GEOMETRICAL MODEL

Combination of rotations and translations

Robotics

N. Marchand

Introduction

Outline

Mechanics

Kinematics

Arm robots

Inner-loop

Geometrical
model

Kinematic model

Dynamical
model

Conclusion

Path planning

Workspace and
obstacles

path planning

Mobile
robotics

Visual
servoing

RX90 robot

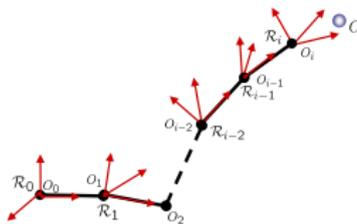

- Let X be the orientation and position of the last segment in \mathcal{R}_0 (usually variable to control)
- **Orientation:** for any \vec{v}
 - $\vec{v}(\mathcal{R}_i) = R_{i-1}^i \vec{v}(\mathcal{R}_{i-1})$
 - $\vec{v}(\mathcal{R}_i) = \prod_{k=1}^i R_{k-1}^k \vec{v}(\mathcal{R}_0) = R_0^i \vec{v}(\mathcal{R}_0)$
- **Position:** for any point C
 - $\overrightarrow{O_0 C}(\mathcal{R}_0) = \overrightarrow{O_0 O_i}(\mathcal{R}_0) + \overrightarrow{O_i C}(\mathcal{R}_0) = \overrightarrow{O_0 O_i}(\mathcal{R}_0) + R_i^0 \overrightarrow{O_i C}(\mathcal{R}_i)$
 - $\overrightarrow{O_0 C}(\mathcal{R}_0) = \overrightarrow{O_0 O_1}(\mathcal{R}_0) + R_1^0 \overrightarrow{O_1 O_2}(\mathcal{R}_1) + \dots + R_{i-1}^0 \overrightarrow{O_{i-1} O_i}(\mathcal{R}_{i-1}) + R_i^0 \overrightarrow{O_i C}(\mathcal{R}_i)$



COMPUTATION OF THE GEOMETRICAL MODEL

Combination of rotations and translations

Robotics

N. Marchand

Introduction

Outline

Mechanics

Kinematics

Arm robots

Inner-loop

Geometrical
model

Kinematic model

Dynamical
model

Conclusion

Path planning

Workspace and
obstacles

path planning

Mobile
robotics

Visual
servoing

RX90 robot

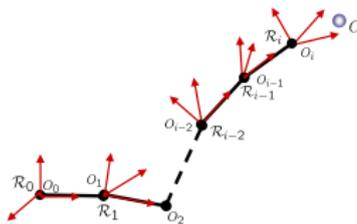

- Let X be the orientation and position of the last segment in \mathcal{R}_0 (usually variable to control)
- **Orientation:** for any \vec{v}
 - $\vec{v}(\mathcal{R}_i) = R_{i-1}^i \vec{v}(\mathcal{R}_{i-1})$
 - $\vec{v}(\mathcal{R}_i) = \prod_{k=1}^i R_{k-1}^k \vec{v}(\mathcal{R}_0) = R_0^i \vec{v}(\mathcal{R}_0)$
- **Position:** for any point C
 - $\overline{O_0 \vec{C}}(\mathcal{R}_0) = \overline{O_0 \vec{O}_i}(\mathcal{R}_0) + \overline{O_i \vec{C}}(\mathcal{R}_0) = \overline{O_0 \vec{O}_i}(\mathcal{R}_0) + R_0^i \overline{O_i \vec{C}}(\mathcal{R}_i)$
 - $\overline{O_0 \vec{C}}(\mathcal{R}_0) = \overline{O_0 \vec{O}_1}(\mathcal{R}_0) + R_1^0 \overline{O_1 \vec{O}_2}(\mathcal{R}_1) + \dots + R_{i-1}^0 \overline{O_{i-1} \vec{O}_i}(\mathcal{R}_{i-1}) + R_i^0 \overline{O_i \vec{C}}(\mathcal{R}_i)$
- where R_i^{i+1} is the rotation matrix from \mathcal{R}_i to \mathcal{R}_{i+1} :



COMPUTATION OF THE GEOMETRICAL MODEL

Combination of rotations and translations

Robotics

N. Marchand

Introduction

Outline

Mechanics

Kinematics

Arm robots

Inner-loop

Geometrical
model

Kinematic model

Dynamical
model

Conclusion

Path planning

Workspace and
obstacles

path planning

Mobile
roboticsVisual
servoing

RX90 robot

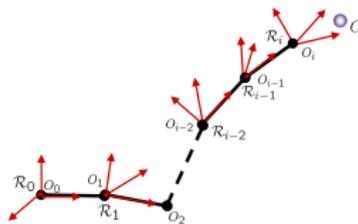

- Let X be the orientation and position of the last segment in \mathcal{R}_0 (usually variable to control)
- **Orientation:** for any \vec{v}
 - $\vec{v}(\mathcal{R}_i) = R_{i-1}^i \vec{v}(\mathcal{R}_{i-1})$
 - $\vec{v}(\mathcal{R}_i) = \prod_{k=1}^i R_{k-1}^k \vec{v}(\mathcal{R}_0) = R_0^i \vec{v}(\mathcal{R}_0)$
- **Position:** for any point C
 - $\overline{O_0 \vec{C}}(\mathcal{R}_0) = \overline{O_0 \vec{O}_i}(\mathcal{R}_0) + \overline{O_i \vec{C}}(\mathcal{R}_0) = \overline{O_0 \vec{O}_i}(\mathcal{R}_0) + R_i^0 \overline{O_i \vec{C}}(\mathcal{R}_i)$
 - $\overline{O_0 \vec{C}}(\mathcal{R}_0) = \overline{O_0 \vec{O}_1}(\mathcal{R}_0) + R_1^0 \overline{O_1 \vec{O}_2}(\mathcal{R}_1) + \dots + R_{i-1}^0 \overline{O_{i-1} \vec{O}_i}(\mathcal{R}_{i-1}) + R_i^0 \overline{O_i \vec{C}}(\mathcal{R}_i)$
- where R_i^{i+1} is the rotation matrix from \mathcal{R}_i to \mathcal{R}_{i+1} :
 - $R_i^{i+1} = R_{i+1}^i{}^T, \det R_i^{i+1} = 1$

COMPUTATION OF THE GEOMETRICAL MODEL

Combination of rotations and translations

Robotics

N. Marchand

- Easy way to compute the geometrical model:
homogeneous coordinates

Introduction

Outline

Mechanics

Kinematics

Arm robots

Inner-loop

**Geometrical
model**

Kinematic model

Dynamical
model

Conclusion

Path planning

Workspace and
obstacles

path planning

Mobile

robotics

Visual

servoing

RX90 robot



COMPUTATION OF THE GEOMETRICAL MODEL

Combination of rotations and translations

Robotics

N. Marchand

Introduction

Outline

Mechanics

Kinematics

Arm robots

Inner-loop

**Geometrical
model**

Kinematic model

Dynamical
model

Conclusion

Path planning

Workspace and
obstacles

path planning

Mobile

robotics

Visual

servoing

RX90 robot

- Easy way to compute the geometrical model:
homogeneous coordinates
- Let $\vec{v} := (v_1 \ v_2 \ v_3)$, then it is equivalent to the
4-dimension vector \vec{V} with $\omega = 1$:

$$V = \begin{pmatrix} v_1\omega \\ v_2\omega \\ v_3\omega \\ \omega \end{pmatrix}$$



COMPUTATION OF THE GEOMETRICAL MODEL

Combination of rotations and translations

Robotics

N. Marchand

Introduction

Outline

Mechanics

Kinematics

Arm robots

Inner-loop

**Geometrical
model**

Kinematic model

Dynamical
model

Conclusion

Path planning

Workspace and
obstacles

path planning

Mobile

robotics

Visual

servoing

RX90 robot

- Easy way to compute the geometrical model:
homogeneous coordinates
- Let $\vec{v} := (v_1 \ v_2 \ v_3)$, then it is equivalent to the 4-dimension vector \vec{V} with $\omega = 1$:

$$V = \begin{pmatrix} v_1\omega \\ v_2\omega \\ v_3\omega \\ \omega \end{pmatrix}$$

- **Translation:** a translation of vector $(a \ b \ c)$ is given by:

$$\text{Trans} = \begin{pmatrix} 1 & 0 & 0 & a \\ 0 & 1 & 0 & b \\ 0 & 0 & 1 & c \\ 0 & 0 & 0 & 1 \end{pmatrix}$$

COMPUTATION OF THE GEOMETRICAL MODEL

Combination of rotations and translations

Robotics

N. Marchand

Introduction

Outline

Mechanics

Kinematics

Arm robots

Inner-loop

Geometrical model

Kinematic model

Dynamical model

Conclusion

Path planning

Workspace and obstacles

path planning

Mobile

robotics

Visual

servoing

RX90 robot

- Easy way to compute the geometrical model:
homogeneous coordinates
- Let $\vec{v} := (v_1 \ v_2 \ v_3)$, then it is equivalent to the 4-dimension vector \vec{V} with $\omega = 1$:

$$V = \begin{pmatrix} v_1\omega \\ v_2\omega \\ v_3\omega \\ \omega \end{pmatrix}$$

- **Translation:** a translation of vector $(a \ b \ c)$ is given by:

$$\text{Trans} = \begin{pmatrix} 1 & 0 & 0 & a \\ 0 & 1 & 0 & b \\ 0 & 0 & 1 & c \\ 0 & 0 & 0 & 1 \end{pmatrix}$$

- **Rotation:** a rotation of matrix R is given by:

$$\text{Rot} = \begin{pmatrix} R & 0_{3 \times 1} \\ 0_{1 \times 3} & 1 \end{pmatrix}$$

Note that still $R^{-1} = R^T$ and $\det(R) = 1$

COMPUTATION OF THE GEOMETRICAL MODEL

Denavit-Hartenberg's convention

Robotics

N. Marchand

Introduction

Outline

Mechanics

Kinematics

Arm robots

Inner-loop

Geometrical model

Kinematic model

Dynamical model

Conclusion

Path planning

Workspace and obstacles

path planning

Mobile robotics

Visual servoing

RX90 robot

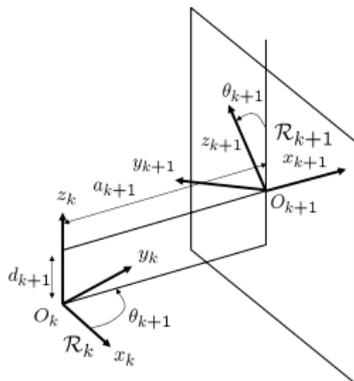

- Consider two successive articulations



COMPUTATION OF THE GEOMETRICAL MODEL

Denavit-Hartenberg's convention

Robotics

N. Marchand

Introduction

Outline

Mechanics

Kinematics

Arm robots

Inner-loop

Geometrical
model

Kinematic model

Dynamical
model

Conclusion

Path planning

Workspace and obstacles

path planning

Mobile
robotics

Visual
servoing

RX90 robot

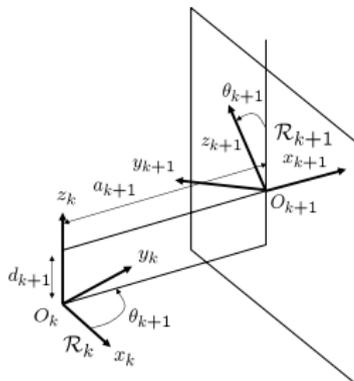

- Consider two successive articulations
- Then, to go from O_k to O_{k+1} and from \mathcal{R}_k to \mathcal{R}_{k+1} , one does successively:



COMPUTATION OF THE GEOMETRICAL MODEL

Denavit-Hartenberg's convention

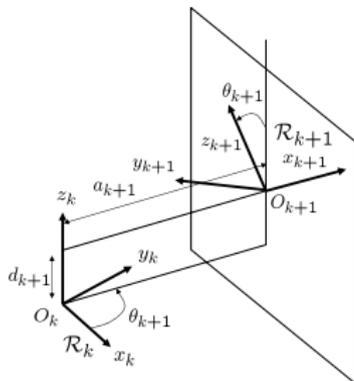

- Consider two successive articulations
- Then, to go from O_k to O_{k+1} and from \mathcal{R}_k to \mathcal{R}_{k+1} , one does successively:
 - One rotation around z_k of angle θ_{k+1}



COMPUTATION OF THE GEOMETRICAL MODEL

Denavit-Hartenberg's convention

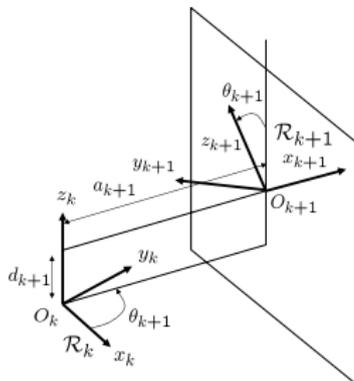

- Consider two successive articulations
- Then, to go from O_k to O_{k+1} and from \mathcal{R}_k to \mathcal{R}_{k+1} , one does successively:
 - One rotation around z_k of angle θ_{k+1}
 - One translation along z_k of distance d_{k+1}



COMPUTATION OF THE GEOMETRICAL MODEL

Denavit-Hartenberg's convention

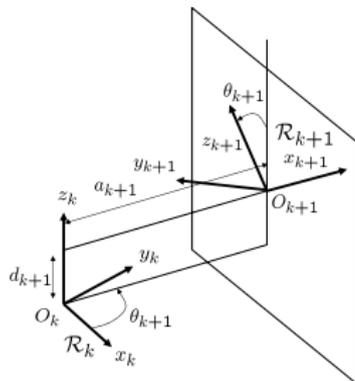

- Consider two successive articulations
- Then, to go from O_k to O_{k+1} and from \mathcal{R}_k to \mathcal{R}_{k+1} , one does successively:
 - One rotation around z_k of angle θ_{k+1}
 - One translation along z_k of distance d_{k+1}
 - One translation along x_{k+1} of distance a_{k+1}



COMPUTATION OF THE GEOMETRICAL MODEL

Denavit-Hartenberg's convention

Robotics

N. Marchand

Introduction

Outline

Mechanics

Kinematics

Arm robots

Inner-loop

Geometrical
model

Kinematic model

Dynamical
model

Conclusion

Path planning

Workspace and
obstacles

path planning

Mobile
robotics

Visual
servoing

RX90 robot

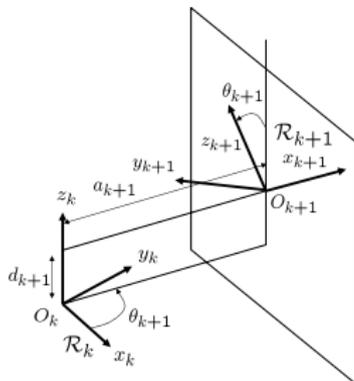

- Consider two successive articulations
- Then, to go from O_k to O_{k+1} and from \mathcal{R}_k to \mathcal{R}_{k+1} , one does successively:
 - One rotation around z_k of angle θ_{k+1}
 - One translation along z_k of distance d_{k+1}
 - One translation along x_{k+1} of distance a_{k+1}
 - One rotation around x_{k+1} of angle α_{k+1}



COMPUTATION OF THE GEOMETRICAL MODEL

Denavit-Hartenberg's convention

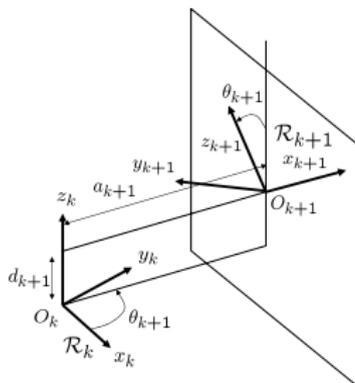

- Consider two successive articulations
- Then, to go from O_k to O_{k+1} and from \mathcal{R}_k to \mathcal{R}_{k+1} , one does successively:
 - One rotation around z_k of angle θ_{k+1}
 - One translation along z_k of distance d_{k+1}
 - One translation along x_{k+1} of distance a_{k+1}
 - One rotation around x_{k+1} of angle α_{k+1}
- The DH parametrization **always exists and is unique**

CONTROL WITH THE GEOMETRICAL MODEL

Robotics

N. Marchand

- Compute the set of θ_i^r corresponding to the reference X^r

Introduction

Outline

Mechanics

Kinematics

Arm robots

Inner-loop

**Geometrical
model**

Kinematic model

Dynamical
model

Conclusion

Path planning

Workspace and
obstacles

path planning

Mobile

robotics

Visual

servoing

RX90 robot

CONTROL WITH THE GEOMETRICAL MODEL

Robotics

N. Marchand

Introduction

Outline

Mechanics

Kinematics

Arm robots

Inner-loop

**Geometrical
model**

Kinematic model

Dynamical
model

Conclusion

Path planning

Workspace and
obstacles

path planning

Mobile
robotics

Visual
servoing

RX90 robot

- Compute the set of θ_i^r corresponding to the reference X^r
- θ_i as a function of X^r is often called “inverse kinematics”



CONTROL WITH THE GEOMETRICAL MODEL

Robotics

N. Marchand

Introduction

Outline

Mechanics

Kinematics

Arm robots

Inner-loop

**Geometrical
model**

Kinematic model

Dynamical
model

Conclusion

Path planning

Workspace and
obstacles

path planning

Mobile
robotics

Visual
servoing

RX90 robot

- Compute the set of θ_i^r corresponding to the reference X^r
- θ_i as a function of X^r is often called “inverse kinematics”
 - The model must be invertible (for any X^r , there is some θ_i^r)



CONTROL WITH THE GEOMETRICAL MODEL

Robotics

N. Marchand

Introduction

Outline

Mechanics

Kinematics

Arm robots

Inner-loop

**Geometrical
model**

Kinematic model

Dynamical
model

Conclusion

Path planning

Workspace and
obstacles

path planning

Mobile
robotics

Visual
servoing

RX90 robot

- Compute the set of θ_i^r corresponding to the reference X^r
- θ_i as a function of X^r is often called “inverse kinematics”
 - The model must be invertible (for any X^r , there is some θ_i^r)
 - We talk about *resolvable robots*



CONTROL WITH THE GEOMETRICAL MODEL

Robotics

N. Marchand

Introduction

Outline

Mechanics

Kinematics

Arm robots

Inner-loop

**Geometrical
model**

Kinematic model

Dynamical
model

Conclusion

Path planning

Workspace and
obstacles

path planning

Mobile
robotics

Visual
servoing

RX90 robot

- Compute the set of θ_i^r corresponding to the reference X^r
- θ_i as a function of X^r is often called “inverse kinematics”
 - The model must be invertible (for any X^r , there is some θ_i^r)
 - We talk about *resolvable robots*
 - Can be inverted using a optimization procedure



CONTROL WITH THE GEOMETRICAL MODEL

Robotics

N. Marchand

Introduction

Outline

Mechanics

Kinematics

Arm robots

Inner-loop

Geometrical
model

Kinematic model

Dynamical
model

Conclusion

Path planning

Workspace and
obstacles

path planning

Mobile robotics

Visual servoing

RX90 robot

- Compute the set of θ_i^r corresponding to the reference X^r
- θ_i as a function of X^r is often called “inverse kinematics”
 - The model must be invertible (for any X^r , there is some θ_i^r)
 - We talk about *resolvable robots*
 - Can be inverted using a optimization procedure
- Make a step in the inner control loop to go from θ_i^0 to θ_i^r



CONTROL WITH THE GEOMETRICAL MODEL

Robotics

N. Marchand

Introduction

Outline

Mechanics

Kinematics

Arm robots

Inner-loop

Geometrical
model

Kinematic model

Dynamical
model

Conclusion

Path planning

Workspace and
obstacles

path planning

Mobile robotics

Visual servoing

RX90 robot

- Compute the set of θ_i^r corresponding to the reference X^r
- θ_i as a function of X^r is often called “inverse kinematics”
 - The model must be invertible (for any X^r , there is some θ_i^r)
 - We talk about *resolvable robots*
 - Can be inverted using a optimization procedure
- Make a step in the inner control loop to go from θ_i^0 to θ_i^r
- **Drawbacks:** the actuators are in closed loop but the robot is in open-loop



CONTROL WITH THE GEOMETRICAL MODEL

Robotics

N. Marchand

Introduction

Outline

Mechanics

Kinematics

Arm robots

Inner-loop

Geometrical
model

Kinematic model

Dynamical
model

Conclusion

Path planning

Workspace and
obstacles

path planning

Mobile robotics

Visual servoing

RX90 robot

- Compute the set of θ_i^r corresponding to the reference X^r
- θ_i as a function of X^r is often called “inverse kinematics”
 - The model must be invertible (for any X^r , there is some θ_i^r)
 - We talk about *resolvable robots*
 - Can be inverted using a optimization procedure
- Make a step in the inner control loop to go from θ_i^0 to θ_i^r
- **Drawbacks:** the actuators are in closed loop but the robot is in open-loop
 - what about the speed ?



CONTROL WITH THE GEOMETRICAL MODEL

Robotics

N. Marchand

Introduction

Outline

Mechanics

Kinematics

Arm robots

Inner-loop

Geometrical
model

Kinematic model

Dynamical
model

Conclusion

Path planning

Workspace and
obstacles

path planning

Mobile

robotics

Visual

servoing

RX90 robot

- Compute the set of θ_i^r corresponding to the reference X^r
- θ_i as a function of X^r is often called “inverse kinematics”
 - The model must be invertible (for any X^r , there is some θ_i^r)
 - We talk about *resolvable robots*
 - Can be inverted using a optimization procedure
- Make a step in the inner control loop to go from θ_i^0 to θ_i^r
- **Drawbacks:** the actuators are in closed loop but the robot is in open-loop
 - what about the speed ?
 - the trajectory is not well defined (obstacle avoidance, etc.)

CONTROL WITH THE GEOMETRICAL MODEL

Robotics

N. Marchand

Introduction

Outline

Mechanics

Kinematics

Arm robots

Inner-loop

Geometrical model

Kinematic model

Dynamical model

Conclusion

Path planning

Workspace and obstacles

path planning

Mobile robotics

Visual servoing

RX90 robot

- Compute the set of θ_i^r corresponding to the reference X^r
- θ_i as a function of X^r is often called “inverse kinematics”
 - The model must be invertible (for any X^r , there is some θ_i^r)
 - We talk about *resolvable robots*
 - Can be inverted using a optimization procedure
- Make a step in the inner control loop to go from θ_i^0 to θ_i^r
- **Drawbacks:** the actuators are in closed loop but the robot is in open-loop
 - what about the speed ?
 - the trajectory is not well defined (obstacle avoidance, etc.)
 - dry friction if multiple X^d



CONTROL WITH THE GEOMETRICAL MODEL

Robotics

N. Marchand

Introduction

Outline

Mechanics

Kinematics

Arm robots

Inner-loop

Geometrical
model

Kinematic model

Dynamical
model

Conclusion

Path planning

Workspace and
obstacles

path planning

Mobile
robotics

Visual
servoing

RX90 robot

- Compute the set of θ_i^r corresponding to the reference X^r
- θ_i as a function of X^r is often called “inverse kinematics”
 - The model must be invertible (for any X^r , there is some θ_i^r)
 - We talk about *resolvable robots*
 - Can be inverted using a optimization procedure
- Make a step in the inner control loop to go from θ_i^0 to θ_i^r
- **Drawbacks:** the actuators are in closed loop but the robot is in open-loop
 - what about the speed ?
 - the trajectory is not well defined (obstacle avoidance, etc.)
 - dry friction if multiple X^d
 - what about the influence of the weight (that depends upon the configuration)



CONTROL WITH THE GEOMETRICAL MODEL

Robotics

N. Marchand

Introduction

Outline

Mechanics

Kinematics

Arm robots

Inner-loop

Geometrical
model

Kinematic model

Dynamical
model

Conclusion

Path planning

Workspace and
obstacles

path planning

Mobile
robotics

Visual
servoing

RX90 robot

- Compute the set of θ_i^r corresponding to the reference X^r
- θ_i as a function of X^r is often called “inverse kinematics”
 - The model must be invertible (for any X^r , there is some θ_i^r)
 - We talk about *resolvable robots*
 - Can be inverted using a optimization procedure
- Make a step in the inner control loop to go from θ_i^0 to θ_i^r
- **Drawbacks:** the actuators are in closed loop but the robot is in open-loop
 - what about the speed ?
 - the trajectory is not well defined (obstacle avoidance, etc.)
 - dry friction if multiple X^d
 - what about the influence of the weight (that depends upon the configuration)
 - inertia may cause overshoot or oscillations



Exercise

- Compute the matrix transformation of the Denavit-Hartenberg's convention

Robotics

N. Marchand

Introduction

Outline

Mechanics

Kinematics

Arm robots

Inner-loop

**Geometrical
model**

Kinematic model

Dynamical
model

Conclusion

Path planning

Workspace and
obstacles

path planning

Mobile
robotics

Visual
servoing

RX90 robot



Exercise

Robotics

N. Marchand

Introduction

Outline

Mechanics

Kinematics

Arm robots

Inner-loop

**Geometrical
model**

Kinematic model

Dynamical
model

Conclusion

Path planning

Workspace and
obstacles

path planning

Mobile

robotics

Visual

servoing

RX90 robot

- Compute the matrix transformation of the Denavit-Hartenberg's convention
 - One rotation around z_k of angle θ_{k+1} :

$$R_1 = \begin{pmatrix} c\theta_{k+1} & -s\theta_{k+1} & 0 & 0 \\ s\theta_{k+1} & c\theta_{k+1} & 0 & 0 \\ 0 & 0 & 1 & 0 \\ 0 & 0 & 0 & 1 \end{pmatrix}$$



Exercise

Robotics

N. Marchand

Introduction

Outline

Mechanics

Kinematics

Arm robots

Inner-loop

Geometrical
model

Kinematic model

Dynamical
model

Conclusion

Path planning

Workspace and
obstacles

path planning

Mobile
robotics

Visual
servoing

RX90 robot

- Compute the matrix transformation of the Denavit-Hartenberg's convention

- One rotation around z_k of angle θ_{k+1} :

$$R_1 = \begin{pmatrix} c\theta_{k+1} & -s\theta_{k+1} & 0 & 0 \\ s\theta_{k+1} & c\theta_{k+1} & 0 & 0 \\ 0 & 0 & 1 & 0 \\ 0 & 0 & 0 & 1 \end{pmatrix}$$

- One translation along z_k of distance d_{k+1}

$$T_1 = \begin{pmatrix} 1 & 0 & 0 & 0 \\ 0 & 1 & 0 & 0 \\ 0 & 0 & 1 & d_{k+1} \\ 0 & 0 & 0 & 1 \end{pmatrix}$$



Exercise

Robotics

N. Marchand

Introduction

Outline

Mechanics

Kinematics

Arm robots

Inner-loop

Geometrical
model

Kinematic model

Dynamical
model

Conclusion

Path planning

Workspace and
obstacles

path planning

Mobile

robotics

Visual

servoing

RX90 robot

- Compute the matrix transformation of the Denavit-Hartenberg's convention

- One rotation around z_k of angle θ_{k+1} :

$$R_1 = \begin{pmatrix} c\theta_{k+1} & -s\theta_{k+1} & 0 & 0 \\ s\theta_{k+1} & c\theta_{k+1} & 0 & 0 \\ 0 & 0 & 1 & 0 \\ 0 & 0 & 0 & 1 \end{pmatrix}$$

- One translation along z_k of distance d_{k+1}

$$T_1 = \begin{pmatrix} 1 & 0 & 0 & 0 \\ 0 & 1 & 0 & 0 \\ 0 & 0 & 1 & d_{k+1} \\ 0 & 0 & 0 & 1 \end{pmatrix}$$

- One translation along x_{k+1} of distance a_{k+1}

$$T_2 = \begin{pmatrix} 1 & 0 & 0 & a_{k+1} \\ 0 & 1 & 0 & 0 \\ 0 & 0 & 1 & 0 \\ 0 & 0 & 0 & 1 \end{pmatrix}$$



Exercise

Robotics

N. Marchand

Introduction

Outline

Mechanics

Kinematics

Arm robots

Inner-loop

Geometrical
model

Kinematic model

Dynamical
model

Conclusion

Path planning

Workspace and
obstacles

path planning

Mobile
robotics

Visual
servoing

RX90 robot

- Compute the matrix transformation of the Denavit-Hartenberg's convention

- One rotation around z_k of angle θ_{k+1} :

$$R_1 = \begin{pmatrix} c\theta_{k+1} & -s\theta_{k+1} & 0 & 0 \\ s\theta_{k+1} & c\theta_{k+1} & 0 & 0 \\ 0 & 0 & 1 & 0 \\ 0 & 0 & 0 & 1 \end{pmatrix}$$

- One translation along z_k of distance d_{k+1}

$$T_1 = \begin{pmatrix} 1 & 0 & 0 & 0 \\ 0 & 1 & 0 & 0 \\ 0 & 0 & 1 & d_{k+1} \\ 0 & 0 & 0 & 1 \end{pmatrix}$$

- One translation along x_{k+1} of distance a_{k+1}

$$T_2 = \begin{pmatrix} 1 & 0 & 0 & a_{k+1} \\ 0 & 1 & 0 & 0 \\ 0 & 0 & 1 & 0 \\ 0 & 0 & 0 & 1 \end{pmatrix}$$

- One rotation around x_{k+1} of angle α_{k+1}

$$R_2 = \begin{pmatrix} 1 & 0 & 0 & 0 \\ 0 & c\alpha_{k+1} & -s\alpha_{k+1} & 0 \\ 0 & s\alpha_{k+1} & c\alpha_{k+1} & 0 \\ 0 & 0 & 0 & 1 \end{pmatrix}$$



Exercise

Robotics

N. Marchand

Introduction

Outline

Mechanics

Kinematics

Arm robots

Inner-loop

Geometrical model

Kinematic model

Dynamical model

Conclusion

Path planning

Workspace and obstacles

path planning

Mobile robotics

Visual servoing

RX90 robot

- Compute the matrix transformation of the Denavit-Hartenberg's convention

- One rotation around z_k of angle θ_{k+1} :

$$R_1 = \begin{pmatrix} c\theta_{k+1} & -s\theta_{k+1} & 0 & 0 \\ s\theta_{k+1} & c\theta_{k+1} & 0 & 0 \\ 0 & 0 & 1 & 0 \\ 0 & 0 & 0 & 1 \end{pmatrix}$$

- One translation along z_k of distance d_{k+1}

$$T_1 = \begin{pmatrix} 1 & 0 & 0 & 0 \\ 0 & 1 & 0 & 0 \\ 0 & 0 & 1 & d_{k+1} \\ 0 & 0 & 0 & 1 \end{pmatrix}$$

- One translation along x_{k+1} of distance a_{k+1}

$$T_2 = \begin{pmatrix} 1 & 0 & 0 & a_{k+1} \\ 0 & 1 & 0 & 0 \\ 0 & 0 & 1 & 0 \\ 0 & 0 & 0 & 1 \end{pmatrix}$$

- One rotation around x_{k+1} of angle α_{k+1}

$$R_2 = \begin{pmatrix} 1 & 0 & 0 & 0 \\ 0 & c\alpha_{k+1} & -s\alpha_{k+1} & 0 \\ 0 & s\alpha_{k+1} & c\alpha_{k+1} & 0 \\ 0 & 0 & 0 & 1 \end{pmatrix}$$

- The matrix transformation of the Denavit-Hartenberg's convention is: $R_2 \cdot T_2 \cdot T_1 \cdot R_1$

Robotics

N. Marchand

Introduction

Outline

Mechanics

Kinematics

Arm robots

Inner-loop

Geometrical
model

Kinematic model

Dynamical
model

Conclusion

Path planning

Workspace and
obstacles

path planning

Mobile
robotics

Visual
servoing

RX90 robot

- 1 Introduction
- 2 Outline
- 3 Mechanics basis
- 4 Kinematics and dynamics of robots**
 - Arm robots
 - Inner-loop
 - Geometrical model
 - Kinematic model**
 - Dynamical model
 - Conclusion
- 5 Path planning
 - Workspace and obstacles
 - Path planning problem formulation
- 6 Mobile robotics
- 7 Visual servoing
- 8 Stäubli RX90 robot

KINEMATIC MODEL OF ROBOTS

- Express the infinitesimal movement dX as a function of speed of the actuators $\frac{d\theta}{dt}$

Robotics

N. Marchand

Introduction

Outline

Mechanics

Kinematics

Arm robots

Inner-loop

Geometrical
model

Kinematic model

Dynamical
model

Conclusion

Path planning

Workspace and
obstacles

path planning

Mobile

robotics

Visual

servoing

RX90 robot



KINEMATIC MODEL OF ROBOTS

Robotics

- Express the infinitesimal movement dX as a function of speed of the actuators $\frac{d\theta}{dt}$
- Sometimes called “velocity kinematics”

N. Marchand

Introduction

Outline

Mechanics

Kinematics

Arm robots

Inner-loop

Geometrical
model

Kinematic model

Dynamical
model

Conclusion

Path planning

Workspace and
obstacles

path planning

Mobile
robotics

Visual
servoing

RX90 robot



KINEMATIC MODEL OF ROBOTS

Robotics

- Express the infinitesimal movement dX as a function of speed of the actuators $\frac{d\theta}{dt}$
- Sometimes called “velocity kinematics”
- Assumes that, thanks to inner-loops, actuators speeds can be assumed to be control variables

N. Marchand

Introduction

Outline

Mechanics

Kinematics

Arm robots

Inner-loop

Geometrical
model

Kinematic model

Dynamical
model

Conclusion

Path planning

Workspace and
obstacles

path planning

Mobile

robotics

Visual

servoing

RX90 robot



KINEMATIC MODEL OF ROBOTS

Robotics

N. Marchand

Introduction

Outline

Mechanics

Kinematics

Arm robots
Inner-loop
Geometrical
model

Kinematic model

Dynamical
model
Conclusion

Path planning

Workspace and
obstacles
path planning

Mobile
robotics

Visual
servoing

RX90 robot

- Express the infinitesimal movement dX as a function of speed of the actuators $\frac{d\theta}{dt}$
- Sometimes called “velocity kinematics”
- Assumes that, thanks to inner-loops, actuators speeds can be assumed to be control variables
- The kinematic model is “simply” the derivation of the geometric model

$$X = f(\theta_0, \theta_1, \dots, \theta_n):$$

$$\dot{X} = \frac{\partial f}{\partial \theta} \dot{\theta}$$

KINEMATIC MODEL OF ROBOTS

Robotics

N. Marchand

Introduction

Outline

Mechanics

Kinematics

 Arm robots
 Inner-loop
 Geometrical
 model

Kinematic model

 Dynamical
 model
 Conclusion

Path planning

 Workspace and
 obstacles
 path planning

 Mobile
 robotics

 Visual
 servoing

RX90 robot

- Express the infinitesimal movement dX as a function of speed of the actuators $\frac{d\theta}{dt}$
- Sometimes called “velocity kinematics”
- Assumes that, thanks to inner-loops, actuators speeds can be assumed to be control variables
- The kinematic model is “simply” the derivation of the geometric model

$$X = f(\theta_0, \theta_1, \dots, \theta_n):$$

$$\dot{X} = \frac{\partial f}{\partial \theta} \dot{\theta}$$

- $J := \frac{\partial f}{\partial \theta}$ is called the *Jacobian* of the robot

KINEMATIC MODEL OF ROBOTS

Robotics

N. Marchand

Introduction

Outline

Mechanics

Kinematics

Arm robots

Inner-loop

 Geometrical
model

Kinematic model

 Dynamical
model

Conclusion

Path planning

Workspace and

obstacles

path planning

Mobile

robotics

Visual

servoing

RX90 robot

- Express the infinitesimal movement dX as a function of speed of the actuators $\frac{d\theta}{dt}$
- Sometimes called “velocity kinematics”
- Assumes that, thanks to inner-loops, actuators speeds can be assumed to be control variables
- The kinematic model is “simply” the derivation of the geometric model

$$X = f(\theta_0, \theta_1, \dots, \theta_n):$$

$$\dot{X} = \frac{\partial f}{\partial \theta} \dot{\theta}$$

- $J := \frac{\partial f}{\partial \theta}$ is called the *Jacobian* of the robot
- J represents the instantaneous transformation between a vector of joint velocities and the linear and angular velocities of the end-effector



KINEMATIC MODEL OF ROBOTS

Robotics

N. Marchand

Introduction

Outline

Mechanics

Kinematics

Arm robots

Inner-loop

Geometrical
model

Kinematic model

Dynamical
model

Conclusion

Path planning

Workspace and
obstacles

path planning

Mobile

robotics

Visual

servoing

RX90 robot

- Express the infinitesimal movement dX as a function of speed of the actuators $\frac{d\theta}{dt}$
- Sometimes called "velocity kinematics"
- Assumes that, thanks to inner-loops, actuators speeds can be assumed to be control variables
- The kinematic model is "simply" the derivation of the geometric model

$$X = f(\theta_0, \theta_1, \dots, \theta_n):$$

$$\dot{X} = \frac{\partial f}{\partial \theta} \dot{\theta}$$

- $J := \frac{\partial f}{\partial \theta}$ is called the *Jacobian* of the robot
- J represents the instantaneous transformation between a vector of joint velocities and the linear and angular velocities of the end-effector
- J can be decomposed into J_v and J_ω so that:

$$\dot{x}_n^{\mathcal{R}_f} = J_v \dot{\theta}$$

$$\omega_n^{\mathcal{R}_f} = J_\omega \dot{\theta}$$



KINEMATIC MODEL OF ROBOTS

Robotics

N. Marchand

Introduction

Outline

Mechanics

Kinematics

Arm robots

Inner-loop

Geometrical
model

Kinematic model

Dynamical
model

Conclusion

Path planning

Workspace and
obstacles

path planning

Mobile
roboticsVisual
servoing

RX90 robot

- Express the infinitesimal movement dX as a function of speed of the actuators $\frac{d\theta}{dt}$
- Sometimes called "velocity kinematics"
- Assumes that, thanks to inner-loops, actuators speeds can be assumed to be control variables

- The kinematic model is "simply" the derivation of the geometric model

$$X = f(\theta_0, \theta_1, \dots, \theta_n):$$

$$\dot{X} = \frac{\partial f}{\partial \theta} \dot{\theta}$$

- $J := \frac{\partial f}{\partial \theta}$ is called the *Jacobian* of the robot
- J represents the instantaneous transformation between a vector of joint velocities and the linear and angular velocities of the end-effector
- J can be decomposed into J_v and J_ω so that:

$$\begin{aligned} \dot{x}_n^{\mathcal{R}_f} &= J_v \dot{\theta} \\ \omega_n^{\mathcal{R}_f} &= J_\omega \dot{\theta} \end{aligned}$$

- The kinematic model can also be obtained using the composition of speed and decomposing the Denavit-Hartenberg's parametrization:

$$R(z, \theta) T(z, d) T(x^+, a) R(x^+, \alpha)$$



KINEMATIC MODEL OF ROBOTS

Robotics

N. Marchand

Introduction

Outline

Mechanics

Kinematics

Arm robots

Inner-loop

Geometrical
model

Kinematic model

Dynamical
model

Conclusion

Path planning

Workspace and
obstacles

path planning

Mobile robotics

Visual servoing

RX90 robot

- Express the infinitesimal movement dX as a function of speed of the actuators $\frac{d\theta}{dt}$
- Sometimes called "velocity kinematics"
- Assumes that, thanks to inner-loops, actuators speeds can be assumed to be control variables

- The kinematic model is "simply" the derivation of the geometric model

$$X = f(\theta_0, \theta_1, \dots, \theta_n):$$

$$\dot{X} = \frac{\partial f}{\partial \theta} \dot{\theta}$$

- $J := \frac{\partial f}{\partial \theta}$ is called the *Jacobian* of the robot
- J represents the instantaneous transformation between a vector of joint velocities and the linear and angular velocities of the end-effector
- J can be decomposed into J_v and J_ω so that:

$$\begin{aligned} \dot{x}_n^{\mathcal{R}_f} &= J_v \dot{\theta} \\ \omega_n^{\mathcal{R}_f} &= J_\omega \dot{\theta} \end{aligned}$$

- The kinematic model can also be obtained using the composition of speed and decomposing the Denavit-Hartenberg's parametrization:

$$R(z, \theta) T(z, d) T(x^+, a) R(x^+, \alpha)$$

- Fastidious in many cases but systematic ! See books for that

KINEMATIC MODEL OF ROBOTS

Robotics

N. Marchand

Introduction

Outline

Mechanics

Kinematics

Arm robots

Inner-loop

Geometrical
model

Kinematic model

Dynamical
model

Conclusion

Path planning

Workspace and
obstacles

path planning

Mobile

robotics

Visual

servoing

RX90 robot

- Kinematic model can be used if “it can be stopped quasi instantaneously” (quickly w.r.t. the tasks to be done)

KINEMATIC MODEL OF ROBOTS

Robotics

N. Marchand

Introduction

Outline

Mechanics

Kinematics

Arm robots

Inner-loop

Geometrical
model

Kinematic model

Dynamical
model

Conclusion

Path planning

Workspace and
obstacles

path planning

Mobile

robotics

Visual

servoing

RX90 robot

- Kinematic model can be used if “it can be stopped quasi instantaneously” (quickly w.r.t. the tasks to be done)
- As for geometrical model, the dynamics has to be neglected

KINEMATIC MODEL OF ROBOTS

Robotics

N. Marchand

Introduction

Outline

Mechanics

Kinematics

Arm robots
Inner-loop
Geometrical
model

Kinematic model

Dynamical
model
Conclusion

Path planning

Workspace and
obstacles
path planning

Mobile
robotics

Visual
servoing

RX90 robot

- Kinematic model can be used if “it can be stopped quasi instantaneously” (quickly w.r.t. the tasks to be done)
- As for geometrical model, the dynamics has to be neglected
- Many cases can happen:

KINEMATIC MODEL OF ROBOTS

Robotics

N. Marchand

Introduction

Outline

Mechanics

Kinematics

Arm robots

Inner-loop

Geometrical
model

Kinematic model

Dynamical
model

Conclusion

Path planning

Workspace and
obstacles

path planning

Mobile
robotics

Visual
servoing

RX90 robot

- Kinematic model can be used if “it can be stopped quasi instantaneously” (quickly w.r.t. the tasks to be done)
- As for geometrical model, the dynamics has to be neglected
- Many cases can happen:
 - J is square and full rank: miracle !



KINEMATIC MODEL OF ROBOTS

Robotics

N. Marchand

Introduction

Outline

Mechanics

Kinematics

Arm robots

Inner-loop

Geometrical
model

Kinematic model

Dynamical
model

Conclusion

Path planning

Workspace and
obstacles

path planning

Mobile
robotics

Visual
servoing

RX90 robot

- Kinematic model can be used if “it can be stopped quasi instantaneously” (quickly w.r.t. the tasks to be done)
- As for geometrical model, the dynamics has to be neglected
- Many cases can happen:
 - J is square and full rank: miracle !
 - J is square but for some articulation position, $\det J = 0$ (singularities), the singularities are usually avoided



KINEMATIC MODEL OF ROBOTS

Robotics

N. Marchand

Introduction

Outline

Mechanics

Kinematics

Arm robots

Inner-loop

Geometrical
model

Kinematic model

Dynamical
model

Conclusion

Path planning

Workspace and
obstacles

path planning

Mobile
robotics

Visual
servoing

RX90 robot

- Kinematic model can be used if “it can be stopped quasi instantaneously” (quickly w.r.t. the tasks to be done)
- As for geometrical model, the dynamics has to be neglected
- Many cases can happen:
 - J is square and full rank: miracle !
 - J is square but for some articulation position, $\det J = 0$ (singularities), the singularities are usually avoided
 - J has more columns than rows: add a criterium to find the optimal path

KINEMATIC MODEL OF ROBOTS

Robotics

N. Marchand

Introduction

Outline

Mechanics

Kinematics

Arm robots

Inner-loop

Geometrical model

Kinematic model

Dynamical model

Conclusion

Path planning

Workspace and obstacles

path planning

Mobile robotics

Visual servoing

RX90 robot

- Kinematic model can be used if “it can be stopped quasi instantaneously” (quickly w.r.t. the tasks to be done)
- As for geometrical model, the dynamics has to be neglected
- Many cases can happen:
 - J is square and full rank: miracle !
 - J is square but for some articulation position, $\det J = 0$ (singularities), the singularities are usually avoided
 - J has more columns than rows: add a criterium to find the optimal path
 - J has more rows than columns: impossible configurations of nonholonomic constraints, nonlinear control theory to solve this problem

KINEMATIC MODEL OF ROBOTS

Robotics

N. Marchand

Introduction

Outline

Mechanics

Kinematics

Arm robots

Inner-loop

Geometrical model

Kinematic model

Dynamical model

Conclusion

Path planning

Workspace and obstacles

path planning

Mobile robotics

Visual servoing

RX90 robot

- Kinematic model can be used if “it can be stopped quasi instantaneously” (quickly w.r.t. the tasks to be done)
- As for geometrical model, the dynamics has to be neglected
- Many cases can happen:
 - J is square and full rank: miracle !
 - J is square but for some articulation position, $\det J = 0$ (singularities), the singularities are usually avoided
 - J has more columns than rows: add a criterium to find the optimal path
 - J has more rows than columns: impossible configurations of nonholonomic constraints, nonlinear control theory to solve this problem
- **The kinematic model is a state space representation of a controlled system**



Example of kinematic model

Robotics

N. Marchand

Introduction

Outline

Mechanics

Kinematics

Arm robots
Inner-loop
Geometrical
model

Kinematic model

Dynamical
model
Conclusion

Path planning

Workspace and
obstacles
path planning

Mobile
robotics

Visual
servoing

RX90 robot

- Example: the car in the plane

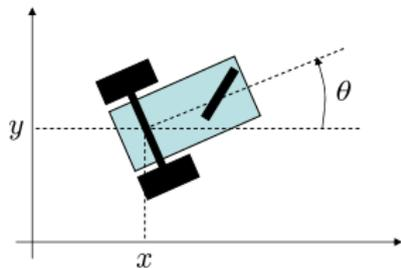

Example of kinematic model

Robotics

N. Marchand

Introduction

Outline

Mechanics

Kinematics

Arm robots

Inner-loop

Geometrical model

Kinematic model

Dynamical model

Conclusion

Path planning

Workspace and obstacles

path planning

Mobile

robotics

Visual

servoing

RX90 robot

- Example: the car in the plane
 - Characterizing variables (state variables): x , y and θ

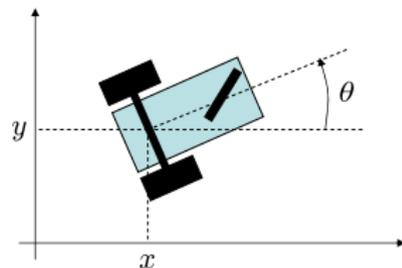



Example of kinematic model

Robotics

N. Marchand

Introduction

Outline

Mechanics

Kinematics

Arm robots

Inner-loop

Geometrical
model

Kinematic model

Dynamical
model

Conclusion

Path planning

Workspace and
obstacles

path planning

Mobile
robotics

Visual
servoing

RX90 robot

- Example: the car in the plane
 - Characterizing variables (state variables): x , y and θ
 - Control variables: speed of each wheels V_r and V_l

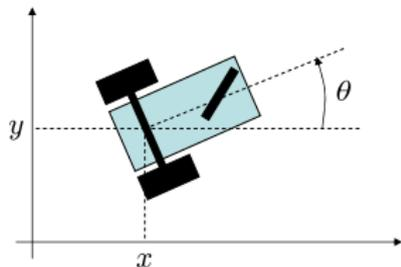

Example of kinematic model

Robotics

N. Marchand

Introduction

Outline

Mechanics

Kinematics

Arm robots

Inner-loop

Geometrical
model

Kinematic model

Dynamical
model

Conclusion

Path planning

Workspace and
obstacles

path planning

Mobile
robotics

Visual
servoing

RX90 robot

- Example: the car in the plane
 - Characterizing variables (state variables): x , y and θ
 - Control variables: speed of each wheels V_r and V_l
 - The kinematic model is given by the relation between \dot{x} , \dot{y} , $\dot{\theta}$ and the controls V_r and V_l

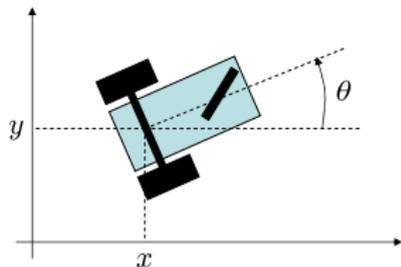

Example of kinematic model

Robotics

N. Marchand

Introduction

Outline

Mechanics

Kinematics

Arm robots

Inner-loop

Geometrical
model

Kinematic model

Dynamical
model

Conclusion

Path planning

Workspace and
obstacles

path planning

Mobile

robotics

Visual

servoing

RX90 robot

- Example: the car in the plane
 - Characterizing variables (state variables): x , y and θ
 - Control variables: speed of each wheels V_r and V_l
 - The kinematic model is given by the relation between \dot{x} , \dot{y} , $\dot{\theta}$ and the controls V_r and V_l
 - What is the kinematic model of the car ?

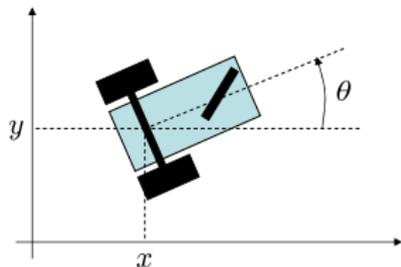



Example of kinematic model

Robotics

N. Marchand

Introduction

Outline

Mechanics

Kinematics

Arm robots

Inner-loop

Geometrical
model

Kinematic model

Dynamical
model

Conclusion

Path planning

Workspace and
obstacles

path planning

Mobile

robotics

Visual

servoing

RX90 robot

- Example: the car in the plane
 - Characterizing variables (state variables): x , y and θ
 - Control variables: speed of each wheels V_r and V_l
 - The kinematic model is given by the relation between \dot{x} , \dot{y} , $\dot{\theta}$ and the controls V_r and V_l
 - What is the kinematic model of the car ?
 - What is the expression of the Jacobian of this robot ?

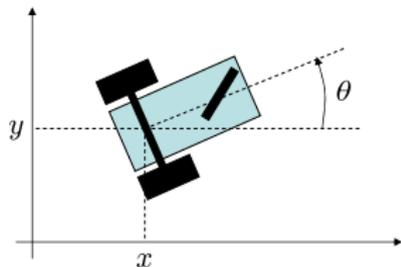

$$\dot{x} = \frac{V_l + V_r}{2} \cos \theta$$

$$\dot{y} = \frac{V_l + V_r}{2} \sin \theta$$

$$\dot{\theta} = \frac{V_r - V_l}{d}$$



Example of kinematic model

Robotics

N. Marchand

Introduction

Outline

Mechanics

Kinematics

Arm robots

Inner-loop

Geometrical
model

Kinematic model

Dynamical
model

Conclusion

Path planning

Workspace and
obstacles
path planning

Mobile
robotics

Visual
servoing

RX90 robot

- Example: the car in the plane
 - Characterizing variables (state variables): x , y and θ
 - Control variables: speed of each wheels V_r and V_l
 - The kinematic model is given by the relation between \dot{x} , \dot{y} , $\dot{\theta}$ and the controls V_r and V_l
 - What is the kinematic model of the car ?
 - What is the expression of the Jacobian of this robot ?
 - Is this system underactuated or overactuated ? Explain why

$$J = \frac{1}{2} \begin{pmatrix} \cos \theta & \cos \theta \\ \sin \theta & \sin \theta \\ -\frac{2}{d} & \frac{2}{d} \end{pmatrix}$$

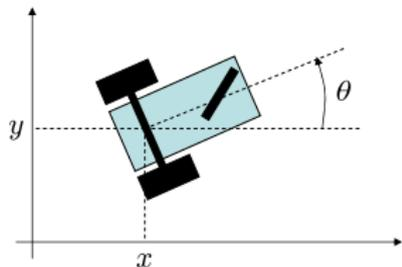

$$\dot{x} = \frac{V_l + V_r}{2} \cos \theta$$

$$\dot{y} = \frac{V_l + V_r}{2} \sin \theta$$

$$\dot{\theta} = \frac{V_r - V_l}{d}$$

Relation between workspace forces and joint torques

Robotics

N. Marchand

Introduction

Outline

Mechanics

Kinematics

Arm robots

Inner-loop

Geometrical
model

Kinematic model

Dynamical
model

Conclusion

Path planning

Workspace and
obstacles

path planning

Mobile

robotics

Visual

servoing

RX90 robot

- The workspace forces and joint torques are linked with the relation:

$$\tau = J_V^T F$$

Relation between workspace forces and joint torques

Robotics

N. Marchand

Introduction

Outline

Mechanics

Kinematics

Arm robots

Inner-loop

Geometrical
model

Kinematic model

Dynamical
model

Conclusion

Path planning

Workspace and
obstacles

path planning

Mobile

robotics

Visual

servoing

RX90 robot

- The workspace forces and joint torques are linked with the relation:

$$\tau = J_V^T F$$

- the Jacobian must be derived at each origin O_i of each link frame

Kinematic redundancy

Robotics

N. Marchand

Introduction

Outline

Mechanics

Kinematics

Arm robots

Inner-loop

Geometrical
model

Kinematic model

Dynamical
model

Conclusion

Path planning

Workspace and
obstacles

path planning

Mobile

robotics

Visual

servoing

RX90 robot

When a robot is given by its kinematic model $\dot{X} = J\dot{\theta}$

- J is usually $n \times p$ with $X \in \mathbb{R}^n$ and $\theta \in \mathbb{R}^p$
- $r = p - n$ is called the **kinematic redundancy number**
- When $r < 0$, the robot is **underactuated**, usually the case with mobile robots \Rightarrow **advanced control**
- When $r > 0$, the robot is **overactuated**. It has redundancy.

For a robot with redundancy, one can write:

- $J = \begin{pmatrix} J_n & J_{p-n} \end{pmatrix}$ with J_n invertible



Control through the kinematic equation

Robotics

N. Marchand

Introduction

Outline

Mechanics

Kinematics

Arm robots

Inner-loop

Geometrical
model

Kinematic model

Dynamical
model

Conclusion

Path planning

Workspace and
obstacles

path planning

Mobile
robotics

Visual
servoing

RX90 robot

Control with J^t Take a robot given by its kinematic model
 $\dot{X} = J\dot{\theta}$

- Control with J^t

- Apply a fictive force $F = K(X - X_d)$ with K positive and symmetric
- Take $\dot{\theta} = J^t F = J^t K(X - X_d) = J^t K e$
- Then the elastic potential $\Phi(e) = \frac{1}{2} e^t K e$ is such that

$$\dot{\Phi}(e) = -e^t K J J^t K e < 0$$

- $e \rightarrow 0, X \rightarrow X_d$
- Automatically handles redundancy

Control through the kinematic equation

Robotics

N. Marchand

Introduction

Outline

Mechanics

Kinematics

Arm robots
Inner-loop
Geometrical
model

Kinematic model

Dynamical
model
Conclusion

Path planning

Workspace and
obstacles
path planning

Mobile

robotics

Visual

servoing

RX90 robot

Control with J^+ Take a robot given by its kinematic model

$$\dot{X} = J\dot{\theta}$$

- Control with $J^+ := J^t(JJ^t)^{-1}$
 - J^+ is the Moore-Penrose pseudo-inverse (`pinv` in Matlab)
 - Can be obtained through SVD decomposition. $J = U\Delta V^t$, Δ diagonal $\implies J^+ = V\Delta^+U^t$, Δ^+ is the inverse of the nonzero coefficient of Δ
 - Taking $\dot{\theta} = J^+\dot{X}$ minimizes the energy $\dot{\theta}^t\dot{\theta}$
 - Taking $\dot{\theta} = J_M^+\dot{X}$ with $J_M^+ := M^{-1}J^t(JM^{-1}J^t)^{-1}$ minimizes the kinetic energy $T = \frac{1}{2}\dot{\theta}^tM(\theta)\dot{\theta}$

OUTLINE

Robotics

N. Marchand

Introduction

Outline

Mechanics

Kinematics

Arm robots

Inner-loop

Geometrical
model

Kinematic model

**Dynamical
model**

Conclusion

Path planning

Workspace and
obstacles

path planning

Mobile
robotics

Visual
servoing

RX90 robot

- 1 Introduction
- 2 Outline
- 3 Mechanics basis
- 4 Kinematics and dynamics of robots**
 - Arm robots
 - Inner-loop
 - Geometrical model
 - Kinematic model
 - Dynamical model**
 - Conclusion
- 5 Path planning
 - Workspace and obstacles
 - Path planning problem formulation
- 6 Mobile robotics
- 7 Visual servoing
- 8 Stäubli RX90 robot



DYNAMICAL MODEL OF ROBOTS

- Express the accelerations of movement as a function of the actuation variables

Robotics

N. Marchand

Introduction

Outline

Mechanics

Kinematics

Arm robots

Inner-loop

Geometrical
model

Kinematic model

**Dynamical
model**

Conclusion

Path planning

Workspace and
obstacles

path planning

Mobile
robotics

Visual
servoing

RX90 robot

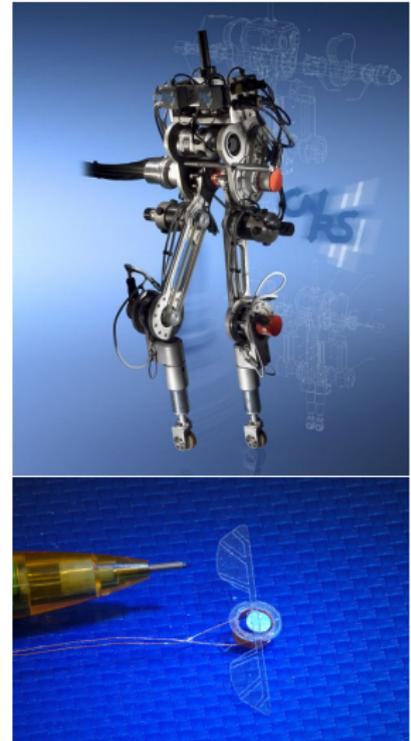



DYNAMICAL MODEL OF ROBOTS

Robotics

N. Marchand

Introduction

Outline

Mechanics

Kinematics

Arm robots

Inner-loop

Geometrical
model

Kinematic model

**Dynamical
model**

Conclusion

Path planning

Workspace and
obstacles

path planning

Mobile
robotics

Visual
servoing

RX90 robot

- Express the **accelerations of movement as a function of the actuation variables**
- The dynamical model is obtained writing the mechanical equations of the system (conservation of momentum)

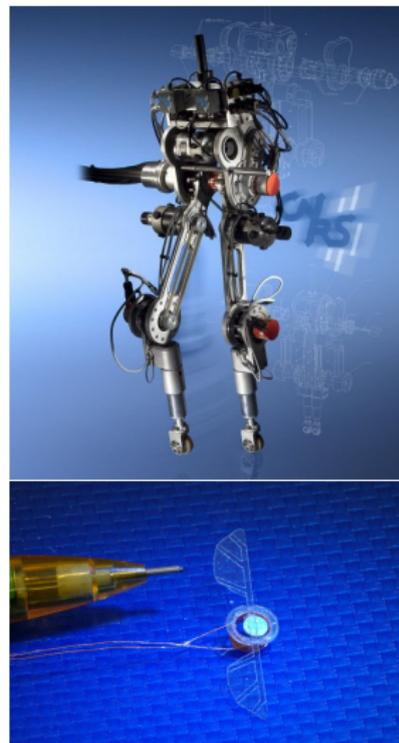



DYNAMICAL MODEL OF ROBOTS

Robotics

N. Marchand

Introduction

Outline

Mechanics

Kinematics

Arm robots

Inner-loop

Geometrical
model

Kinematic model

**Dynamical
model**

Conclusion

Path planning

Workspace and
obstacles

path planning

Mobile
robotics

Visual
servoing

RX90 robot

- Express the **accelerations of movement as a function of the actuation variables**
- The dynamical model is obtained writing the mechanical equations of the system (conservation of momentum)
- Sometimes also includes the actuators dynamics (mainly electrical or pneumatical)

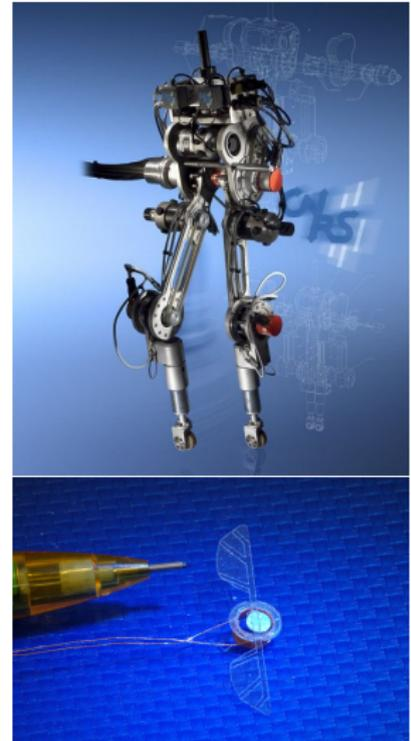



DYNAMICAL MODEL OF ROBOTS

Robotics

N. Marchand

Introduction

Outline

Mechanics

Kinematics

Arm robots
 Inner-loop
 Geometrical model
 Kinematic model
Dynamical model
 Conclusion

Path planning

Workspace and obstacles
 path planning

Mobile robotics

Visual servoing

RX90 robot

- Express the **accelerations of movement as a function of the actuation variables**
- The dynamical model is obtained writing the mechanical equations of the system (conservation of momentum)
- Sometimes also includes the actuators dynamics (mainly electrical or pneumatical)
- Very complex and most of the time impossible to control (too complex to design a control)

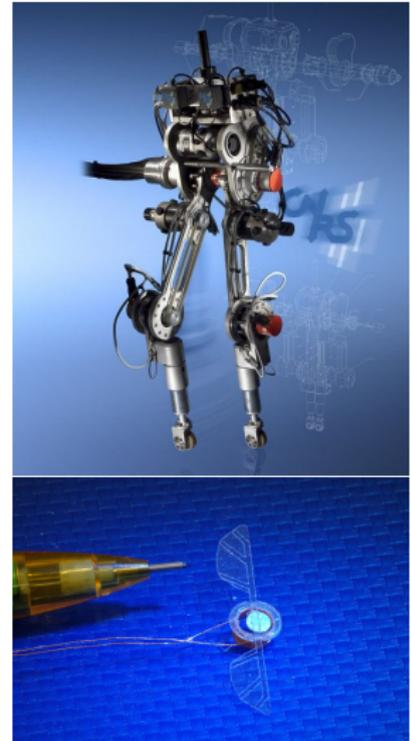



DYNAMICAL MODEL OF ROBOTS

Robotics

N. Marchand

Introduction

Outline

Mechanics

Kinematics

Arm robots
 Inner-loop
 Geometrical model
 Kinematic model
 Dynamical model
 Conclusion

Path planning

Workspace and obstacles
 path planning

Mobile robotics

Visual servoing

RX90 robot

- Express the **accelerations of movement as a function of the actuation variables**
- The dynamical model is obtained writing the mechanical equations of the system (conservation of momentum)
- Sometimes also includes the actuators dynamics (mainly electrical or pneumatical)
- Very complex and most of the time impossible to control (too complex to design a control)
- simplifications are required:

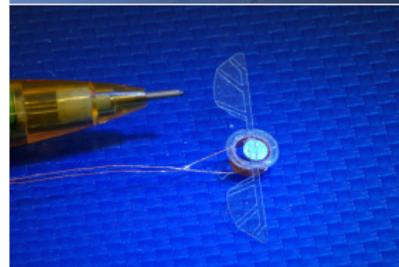



DYNAMICAL MODEL OF ROBOTS

Robotics

N. Marchand

Introduction

Outline

Mechanics

Kinematics

Arm robots
 Inner-loop
 Geometrical model
 Kinematic model
 Dynamical model
 Conclusion

Path planning

Workspace and obstacles
 path planning

Mobile robotics

Visual servoing

RX90 robot

- Express the **accelerations of movement as a function of the actuation variables**
- The dynamical model is obtained writing the mechanical equations of the system (conservation of momentum)
- Sometimes also includes the actuators dynamics (mainly electrical or pneumatical)
- Very complex and most of the time impossible to control (too complex to design a control)
- simplifications are required:
 - based on relative speed of the \neq parts of the robot





DYNAMICAL MODEL OF ROBOTS

Robotics

N. Marchand

Introduction

Outline

Mechanics

Kinematics

Arm robots
 Inner-loop
 Geometrical model
 Kinematic model
 Dynamical model
 Conclusion

Path planning

Workspace and obstacles
 path planning

Mobile robotics

Visual servoing

RX90 robot

- Express the **accelerations of movement as a function of the actuation variables**
- The dynamical model is obtained writing the mechanical equations of the system (conservation of momentum)
- Sometimes also includes the actuators dynamics (mainly electrical or pneumatical)
- Very complex and most of the time impossible to control (too complex to design a control)
- simplifications are required:
 - based on relative speed of the \neq parts of the robot
 - thanks to inner-loops that can render parts instantaneous w.r.t. other parts of the robot

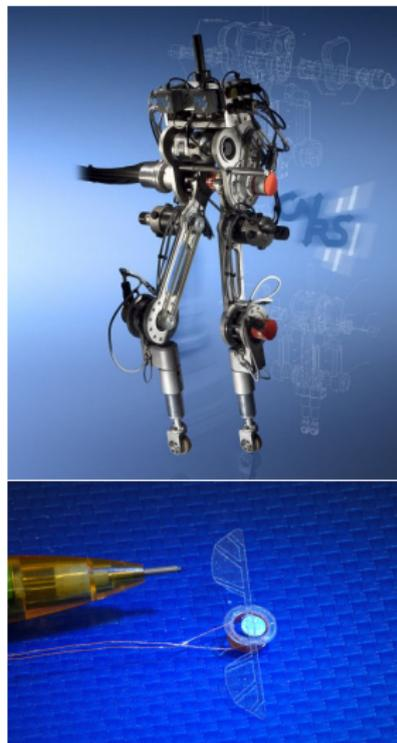



DYNAMICAL MODEL OF ROBOTS

Robotics

N. Marchand

Introduction

Outline

Mechanics

Kinematics

Arm robots
 Inner-loop
 Geometrical model
 Kinematic model
 Dynamical model
 Conclusion

Path planning

Workspace and obstacles
 path planning

Mobile robotics

Visual servoing

RX90 robot

- Express the **accelerations of movement as a function of the actuation variables**
- The dynamical model is obtained writing the mechanical equations of the system (conservation of momentum)
- Sometimes also includes the actuators dynamics (mainly electrical or pneumatical)
- Very complex and most of the time impossible to control (too complex to design a control)
- simplifications are required:
 - based on relative speed of the \neq parts of the robot
 - thanks to inner-loops that can render parts instantaneous w.r.t. other parts of the robot
- Almost never used for arm-robots





DYNAMICAL MODEL OF ROBOTS

Robotics

N. Marchand

Introduction

Outline

Mechanics

Kinematics

Arm robots
 Inner-loop
 Geometrical model
 Kinematic model
 Dynamical model
 Conclusion

Path planning

Workspace and obstacles
 path planning

Mobile robotics

Visual servoing

RX90 robot

- Express the **accelerations of movement as a function of the actuation variables**
- The dynamical model is obtained writing the mechanical equations of the system (conservation of momentum)
- Sometimes also includes the actuators dynamics (mainly electrical or pneumatical)
- Very complex and most of the time impossible to control (too complex to design a control)
- simplifications are required:
 - based on relative speed of the \neq parts of the robot
 - thanks to inner-loops that can render parts instantaneous w.r.t. other parts of the robot
- Almost never used for arm-robots
- Widely used for flying or diving robots (UAVs, AUVs, etc.) or walking robots

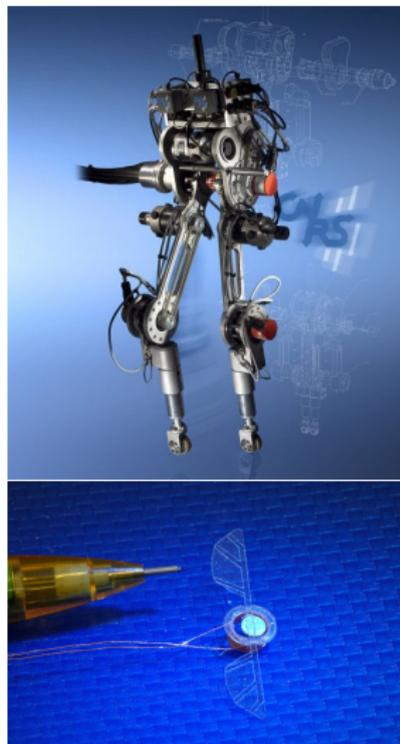

DYNAMICAL MODELS OF ROBOTS

n-link manipulator

Robotics

N. Marchand

Introduction

Outline

Mechanics

Kinematics

Arm robots

Inner-loop

Geometrical
model

Kinematic model

**Dynamical
model**

Conclusion

Path planning

Workspace and
obstacles

path planning

Mobile

robotics

Visual

servoing

RX90 robot

- The dynamical equations are of the form:

$$D(q)\ddot{q} + C(q, \dot{q})\dot{q} + g(q) = r$$

DYNAMICAL MODELS OF ROBOTS

n-link manipulator

Robotics

N. Marchand

Introduction

Outline

Mechanics

Kinematics

Arm robots
Inner-loop
Geometrical
model
Kinematic model

**Dynamical
model**

Conclusion

Path planning

Workspace and
obstacles
path planning

Mobile
robotics

Visual
servoing

RX90 robot

- The dynamical equations are of the form:

$$D(q)\ddot{q} + C(q, \dot{q})\dot{q} + g(q) = r$$

- Obtained thanks to the Euler-Lagrange formalism

DYNAMICAL MODELS OF ROBOTS

n-link manipulator

Robotics

N. Marchand

Introduction

Outline

Mechanics

Kinematics

Arm robots

Inner-loop

Geometrical
model

Kinematic model

**Dynamical
model**

Conclusion

Path planning

Workspace and
obstacles

path planning

Mobile

robotics

Visual

servoing

RX90 robot

- The dynamical equations are of the form:

$$D(q)\ddot{q} + C(q, \dot{q})\dot{q} + g(q) = r$$

- Obtained thanks to the Euler-Lagrange formalism
- q are the generalized coordinates

DYNAMICAL MODELS OF ROBOTS

n-link manipulator

Robotics

N. Marchand

Introduction

Outline

Mechanics

Kinematics

Arm robots

Inner-loop

Geometrical
model

Kinematic model

Dynamical
model

Conclusion

Path planning

Workspace and
obstacles

path planning

Mobile

robotics

Visual

servoing

RX90 robot

- The dynamical equations are of the form:

$$D(q)\ddot{q} + C(q, \dot{q})\dot{q} + g(q) = r$$

- Obtained thanks to the Euler-Lagrange formalism
- q are the generalized coordinates
- $C(q, \dot{q})\dot{q} = \sum_i \sum_j c_{ij}(q)\dot{q}_i\dot{q}_j$

DYNAMICAL MODELS OF ROBOTS

n-link manipulator

Robotics

N. Marchand

Introduction

Outline

Mechanics

Kinematics

Arm robots

Inner-loop

Geometrical
model

Kinematic model

Dynamical
model

Conclusion

Path planning

Workspace and
obstacles

path planning

Mobile

robotics

Visual

servoing

RX90 robot

- The dynamical equations are of the form:

$$D(q)\ddot{q} + C(q, \dot{q})\dot{q} + g(q) = r$$

- Obtained thanks to the Euler-Lagrange formalism
- q are the generalized coordinates
- $C(q, \dot{q})\dot{q} = \sum_i \sum_j c_{ij}(q)\dot{q}_i\dot{q}_j$
 - Centrifugal effect when $i = j$ (term in \dot{q}_i^2)

DYNAMICAL MODELS OF ROBOTS

n -link manipulator

Robotics

N. Marchand

Introduction

Outline

Mechanics

Kinematics

Arm robots

Inner-loop

Geometrical
model

Kinematic model

Dynamical
model

Conclusion

Path planning

Workspace and
obstacles

path planning

Mobile
roboticsVisual
servoing

RX90 robot

- The dynamical equations are of the form:

$$D(q)\ddot{q} + C(q, \dot{q})\dot{q} + g(q) = r$$

- Obtained thanks to the Euler-Lagrange formalism
- q are the generalized coordinates
- $C(q, \dot{q})\dot{q} = \sum_i \sum_j c_{ij}(q)\dot{q}_i\dot{q}_j$
 - Centrifugal effect when $i = j$ (term in \dot{q}_i^2)
 - Coriolis effect when $i \neq j$ (terms in $\dot{q}_i\dot{q}_j$)

DYNAMICAL MODELS OF ROBOTS

n -link manipulator

Robotics

N. Marchand

Introduction

Outline

Mechanics

Kinematics

Arm robots

Inner-loop

Geometrical
model

Kinematic model

Dynamical
model

Conclusion

Path planning

Workspace and
obstacles

path planning

Mobile
roboticsVisual
servoing

RX90 robot

- The dynamical equations are of the form:

$$D(q)\ddot{q} + C(q, \dot{q})\dot{q} + g(q) = r$$

- Obtained thanks to the Euler-Lagrange formalism
- q are the generalized coordinates
- $C(q, \dot{q})\dot{q} = \sum_i \sum_j c_{ij}(q)\dot{q}_i\dot{q}_j$
 - Centrifugal effect when $i = j$ (term in \dot{q}_i^2)
 - Coriolis effect when $i \neq j$ (terms in $\dot{q}_i\dot{q}_j$)
- An important literature on the control of this type of systems can be found

DYNAMICAL MODELS OF ROBOTS

flying and diving robots

Robotics

N. Marchand

Introduction

Outline

Mechanics

Kinematics

Arm robots

Inner-loop

Geometrical model

Kinematic model

Dynamical model

Conclusion

Path planning

Workspace and obstacles

path planning

Mobile

robotics

Visual

servoing

RX90 robot

- The dynamical equations are of the form:

$$\left\{ \begin{array}{l} \dot{\vec{p}} = \vec{v} \\ m\dot{\vec{v}} = -mg\vec{e}_3 + R \begin{pmatrix} F_x \\ F_y \\ F_z \end{pmatrix} \\ \dot{R} = R\vec{\omega}^\times \\ J\dot{\vec{\omega}} = -\vec{\omega}^\times J\vec{\omega} + \begin{pmatrix} \Gamma_r \\ \Gamma_p \\ \Gamma_y \end{pmatrix} \end{array} \right.$$

DYNAMICAL MODELS OF ROBOTS

flying and diving robots

Robotics

N. Marchand

Introduction

Outline

Mechanics

Kinematics

Arm robots

Inner-loop

Geometrical model

Kinematic model

Dynamical model

Conclusion

Path planning

Workspace and obstacles

path planning

Mobile

robotics

Visual

servoing

RX90 robot

- The dynamical equations are of the form:

$$\left\{ \begin{array}{l} \dot{\vec{p}} = \vec{v} \\ m\dot{\vec{v}} = -mg\vec{e}_3 + R \begin{pmatrix} F_x \\ F_y \\ F_z \end{pmatrix} \\ \dot{R} = R\vec{\omega}^\times \\ J\dot{\vec{\omega}} = -\vec{\omega}^\times J\vec{\omega} + \begin{pmatrix} \Gamma_r \\ \Gamma_p \\ \Gamma_y \end{pmatrix} \end{array} \right.$$

- The number of available controls depends upon the system

Robotics

N. Marchand

Introduction

Outline

Mechanics

Kinematics

Arm robots

Inner-loop

Geometrical
model

Kinematic model
Dynamical
model

Conclusion

Path planning

Workspace and
obstacles
path planning

Mobile
robotics

Visual
servoing

RX90 robot

- 1 Introduction
- 2 Outline
- 3 Mechanics basis
- 4 Kinematics and dynamics of robots**
 - Arm robots
 - Inner-loop
 - Geometrical model
 - Kinematic model
 - Dynamical model
 - **Conclusion**
- 5 Path planning
 - Workspace and obstacles
 - Path planning problem formulation
- 6 Mobile robotics
- 7 Visual servoing
- 8 Stäubli RX90 robot

DIFFERENT MODELS OF ROBOTS

Robotics

- **Geometrical model** (or forward kinematic model):

Position of the robot = f (position of the actuators)

N. Marchand

Introduction

Outline

Mechanics

Kinematics

- Arm robots
- Inner-loop
- Geometrical model
- Kinematic model
- Dynamical model
- Conclusion**

Path planning

- Workspace and obstacles
- path planning

Mobile robotics

Visual servoing

RX90 robot

DIFFERENT MODELS OF ROBOTS

Robotics

- **Geometrical model** (or forward kinematic model):

Position of the robot = f (position of the actuators)

- **Inverse geometrical model** (or inverse kinematic model):

Position of the actuators = f (position of the robot)

N. Marchand

Introduction

Outline

Mechanics

Kinematics

Arm robots
Inner-loop
Geometrical model
Kinematic model
Dynamical model
Conclusion

Path planning

Workspace and obstacles
path planning

Mobile robotics

Visual servoing

RX90 robot

DIFFERENT MODELS OF ROBOTS

Robotics

- **Geometrical model** (or forward kinematic model):

Position of the robot = $f(\text{position of the actuators})$

N. Marchand

Introduction

Outline

Mechanics

Kinematics

Arm robots

Inner-loop

Geometrical model

Kinematic model

Dynamical model

Conclusion

- **Inverse geometrical model** (or inverse kinematic model):

Position of the actuators = $f(\text{position of the robot})$

- **Kinematic model (state space representation)** (or velocity kinematic model):

Speed of the robot = $f(\text{position, actuation speed})$

Path planning

Workspace and obstacles

path planning

Mobile

robotics

Visual

servoing

RX90 robot

DIFFERENT MODELS OF ROBOTS

Robotics

- **Geometrical model** (or forward kinematic model):

Position of the robot = f (position of the actuators)

N. Marchand

Introduction

Outline

Mechanics

Kinematics

 Arm robots
 Inner-loop
 Geometrical model
 Kinematic model
 Dynamical model
 Conclusion

- **Inverse geometrical model** (or inverse kinematic model):

Position of the actuators = f (position of the robot)

- **Kinematic model (state space representation)** (or velocity kinematic model):

Speed of the robot = f (position, actuation speed)

Path planning

 Workspace and obstacles
 path planning

- **Dynamical model (state space representation)**:

Robot acceleration = f (position and speed, forces/torques)

Mobile robotics

Visual servoing

RX90 robot

OUTLINE

Robotics

N. Marchand

Introduction

Outline

Mechanics

Kinematics

Arm robots

Inner-loop

Geometrical
model

Kinematic model

Dynamical
model

Conclusion

Path planning

Workspace and
obstacles

path planning

Mobile
robotics

robotics

Visual
servoing

servoing

RX90 robot

- 1 Introduction
- 2 Outline
- 3 Mechanics basis
- 4 Kinematics and dynamics of robots
 - Arm robots
 - Inner-loop
 - Geometrical model
 - Kinematic model
 - Dynamical model
 - Conclusion
- 5 Path planning**
 - **Workspace and obstacles**
 - Path planning problem formulation
- 6 Mobile robotics
- 7 Visual servoing
- 8 Stäubli RX90 robot

PATH PLANNING

Robotics

N. Marchand

Introduction

Outline

Mechanics

Kinematics

- Arm robots
- Inner-loop
- Geometrical model
- Kinematic model
- Dynamical model
- Conclusion

Path planning

- Workspace and obstacles
- path planning

Mobile robotics

Visual servoing

RX90 robot

- Need to choose a path for the end effector that avoids

PATH PLANNING

Robotics

N. Marchand

Introduction

Outline

Mechanics

Kinematics

- Arm robots
- Inner-loop
- Geometrical model
- Kinematic model
- Dynamical model
- Conclusion

Path planning

- Workspace and obstacles
- path planning

Mobile robotics

Visual servoing

RX90 robot

- Need to choose a path for the end effector that avoids
 - collisions



PATH PLANNING

Robotics

N. Marchand

Introduction

Outline

Mechanics

Kinematics

Arm robots
Inner-loop
Geometrical
model
Kinematic model
Dynamical
model
Conclusion

Path planning

Workspace and
obstacles
path planning

Mobile
robotics

Visual
servoing

RX90 robot

- Need to choose a path for the end effector that avoids
 - collisions
 - singularities of the robot



PATH PLANNING

Robotics

N. Marchand

Introduction

Outline

Mechanics

Kinematics

Arm robots
Inner-loop
Geometrical
model
Kinematic model
Dynamical
model
Conclusion

Path planning

Workspace and
obstacles
path planning

Mobile
robotics

Visual
servoing

RX90 robot

- Need to choose a path for the end effector that avoids
 - collisions
 - singularities of the robot
- Collision are easy to characterize in the workspace but may need to be transformed in the configuration space

PATH PLANNING

Robotics

N. Marchand

Introduction

Outline

Mechanics

Kinematics

- Arm robots
- Inner-loop
- Geometrical model
- Kinematic model
- Dynamical model
- Conclusion

Path planning

- Workspace and obstacles
- path planning

Mobile robotics

Visual servoing

RX90 robot

- Need to choose a path for the end effector that avoids
 - collisions
 - singularities of the robot
- Collision are easy to characterize in the workspace but may need to be transformed in the configuration space
- The complexity of obstacle avoidance grows exponentially with the number of DOF

PATH PLANNING

Robotics

N. Marchand

Introduction

Outline

Mechanics

Kinematics

- Arm robots
- Inner-loop
- Geometrical model
- Kinematic model
- Dynamical model
- Conclusion

Path planning

- Workspace and obstacles
- path planning

Mobile robotics

Visual servoing

RX90 robot

- Need to choose a path for the end effector that avoids
 - collisions
 - singularities of the robot
- Collision are easy to characterize in the workspace but may need to be transformed in the configuration space
- The complexity of obstacle avoidance grows exponentially with the number of DOF
- The method used are (usually):

PATH PLANNING

Robotics

N. Marchand

Introduction

Outline

Mechanics

Kinematics

- Arm robots
- Inner-loop
- Geometrical model
- Kinematic model
- Dynamical model
- Conclusion

Path planning

- Workspace and obstacles
- path planning

Mobile robotics

Visual servoing

RX90 robot

- Need to choose a path for the end effector that avoids
 - collisions
 - singularities of the robot
- Collision are easy to characterize in the workspace but may need to be transformed in the configuration space
- The complexity of obstacle avoidance grows exponentially with the number of DOF
- The method used are (usually):
 - Potential field: renders the obstacle repulsive

PATH PLANNING

Robotics

N. Marchand

Introduction

Outline

Mechanics

Kinematics

- Arm robots
- Inner-loop
- Geometrical model
- Kinematic model
- Dynamical model
- Conclusion

Path planning

- Workspace and obstacles
- path planning

Mobile robotics

Visual servoing

RX90 robot

- Need to choose a path for the end effector that avoids
 - collisions
 - singularities of the robot
- Collision are easy to characterize in the workspace but may need to be transformed in the configuration space
- The complexity of obstacle avoidance grows exponentially with the number of DOF
- The method used are (usually):
 - Potential field: renders the obstacle repulsive
 - **Gradient descent** or Probabilistic roadmaps to generate the path

WORKSPACE AND OBSTACLES

Robotics

N. Marchand

Introduction

Outline

Mechanics

Kinematics

- Arm robots
- Inner-loop
- Geometrical model
- Kinematic model
- Dynamical model
- Conclusion

Path planning

- Workspace and obstacles**
- path planning

Mobile robotics

Visual servoing

RX90 robot

- The workspace is the volume W the end effector can reach. Usually divided into:

WORKSPACE AND OBSTACLES

Robotics

N. Marchand

Introduction

Outline

Mechanics

Kinematics

Arm robots

Inner-loop

Geometrical
model

Kinematic model

Dynamical
model

Conclusion

Path planning

**Workspace and
obstacles**

path planning

Mobile robotics

Visual servoing

RX90 robot

- The workspace is the volume W the end effector can reach. Usually divided into:
 - Reachable

WORKSPACE AND OBSTACLES

Robotics

N. Marchand

Introduction

Outline

Mechanics

Kinematics

- Arm robots
- Inner-loop
- Geometrical model
- Kinematic model
- Dynamical model
- Conclusion

Path planning

- Workspace and obstacles**
- path planning

Mobile robotics

Visual servoing

RX90 robot

- The workspace is the volume W the end effector can reach. Usually divided into:
 - Reachable
 - Dexterous

WORKSPACE AND OBSTACLES

Robotics

N. Marchand

Introduction

Outline

Mechanics

Kinematics

- Arm robots
- Inner-loop
- Geometrical model
- Kinematic model
- Dynamical model
- Conclusion

Path planning

- Workspace and obstacles
- path planning

Mobile robotics

Visual servoing

RX90 robot

- The workspace is the volume W the end effector can reach. Usually divided into:
 - Reachable
 - **Dexterous**
- The "configuration" is the "location" of all points of the robot

WORKSPACE AND OBSTACLES

Robotics

N. Marchand

Introduction

Outline

Mechanics

Kinematics

- Arm robots
- Inner-loop
- Geometrical model
- Kinematic model
- Dynamical model
- Conclusion

Path planning

- Workspace and obstacles
- path planning

Mobile robotics

Visual servoing

RX90 robot

- The workspace is the volume W the end effector can reach. Usually divided into:
 - Reachable
 - **Dexterous**
- The "configuration" is the "location" of all points of the robot
 - Configuration answers the question: where is the robot

WORKSPACE AND OBSTACLES

Robotics

N. Marchand

Introduction

Outline

Mechanics

Kinematics

- Arm robots
- Inner-loop
- Geometrical model
- Kinematic model
- Dynamical model
- Conclusion

Path planning

- Workspace and obstacles
- path planning

Mobile robotics

Visual servoing

RX90 robot

- The workspace is the volume W the end effector can reach. Usually divided into:
 - Reachable
 - **Dexterous**
- The "configuration" is the "location" of all points of the robot
 - Configuration answers the question: where is the robot
 - The configuration can be adapted to the problem: from the set of all points of the robot to the sole the effector

WORKSPACE AND OBSTACLES

Robotics

N. Marchand

Introduction

Outline

Mechanics

Kinematics

- Arm robots
- Inner-loop
- Geometrical model
- Kinematic model
- Dynamical model
- Conclusion

Path planning

- Workspace and obstacles
- path planning

Mobile robotics

Visual servoing

RX90 robot

- The workspace is the volume W the end effector can reach. Usually divided into:
 - Reachable
 - **Dexterous**
- The "configuration" is the "location" of all points of the robot
 - Configuration answers the question: where is the robot
 - The configuration can be adapted to the problem: from the set of all points of the robot to the sole the effector
 - The θ_i 's are sufficient to characterize the configuration of an arm robot for arm robots

WORKSPACE AND OBSTACLES

Robotics

N. Marchand

Introduction

Outline

Mechanics

Kinematics

- Arm robots
- Inner-loop
- Geometrical model
- Kinematic model
- Dynamical model
- Conclusion

Path planning

- Workspace and obstacles
- path planning

Mobile robotics

Visual servoing

RX90 robot

- The workspace is the volume W the end effector can reach. Usually divided into:
 - Reachable
 - **Dexterous**
- The "configuration" is the "location" of all points of the robot
 - Configuration answers the question: where is the robot
 - The configuration can be adapted to the problem: from the set of all points of the robot to the sole the effector
 - The θ_i 's are sufficient to characterize the configuration of an arm robot for arm robots
- The set of θ_i 's corresponding to a possible configuration is noted Q



WORKSPACE AND OBSTACLES

Robotics

N. Marchand

Introduction

Outline

Mechanics

Kinematics

Arm robots
Inner-loop
Geometrical
model
Kinematic model
Dynamical
model
Conclusion

Path planning

**Workspace and
obstacles**
path planning

Mobile
robotics

Visual
servoing

RX90 robot

- Obstacles are denoted O_i and the set of obstacle is $O = \cup O_i$



WORKSPACE AND OBSTACLES

Robotics

N. Marchand

Introduction

Outline

Mechanics

Kinematics

- Arm robots
- Inner-loop
- Geometrical model
- Kinematic model
- Dynamical model
- Conclusion

Path planning

- Workspace and obstacles
- path planning

Mobile robotics

Visual servoing

RX90 robot

- Obstacles are denoted O_i and the set of obstacle is $O = \cup O_i$
- Let $\theta \in Q$ and $C(\theta)$ denote the corresponding configuration

WORKSPACE AND OBSTACLES

Robotics

N. Marchand

Introduction

Outline

Mechanics

Kinematics

Arm robots
Inner-loop
Geometrical
model
Kinematic model
Dynamical
model
Conclusion

Path planning

Workspace and
obstacles
path planning

Mobile
robotics

Visual
servoing

RX90 robot

- Obstacles are denoted O_i and the set of obstacle is $O = \cup O_i$
- Let $\theta \in Q$ and $C(\theta)$ denote the corresponding configuration
- Then the workspace can be divided into:



WORKSPACE AND OBSTACLES

Robotics

N. Marchand

Introduction

Outline

Mechanics

Kinematics

Arm robots

Inner-loop

Geometrical
model

Kinematic model

Dynamical
model

Conclusion

Path planning

Workspace and
obstacles

path planning

Mobile

robotics

Visual

servoing

RX90 robot

- Obstacles are denoted O_i and the set of obstacle is $O = \cup O_i$
- Let $\theta \in Q$ and $C(\theta)$ denote the corresponding configuration
- Then the workspace can be divided into:
 - the collision-free configuration subspace $Q_f = \{\theta \in Q \mid C(\theta) \cap O = \emptyset\}$



WORKSPACE AND OBSTACLES

Robotics

N. Marchand

Introduction

Outline

Mechanics

Kinematics

- Arm robots
- Inner-loop
- Geometrical model
- Kinematic model
- Dynamical model
- Conclusion

Path planning

- Workspace and obstacles
- path planning

Mobile

robotics

Visual

servoing

RX90 robot

- Obstacles are denoted O_i and the set of obstacle is $O = \cup O_i$
- Let $\theta \in Q$ and $C(\theta)$ denote the corresponding configuration
- Then the workspace can be divided into:
 - the collision-free configuration subspace $Q_f = \{\theta \in Q \mid C(\theta) \cap O = \emptyset\}$
 - the collision configuration subspace $Q_c = \{\theta \in Q \mid C(\theta) \cap O \neq \emptyset\}$



EXAMPLE: THE CAR

Robotics

N. Marchand

Introduction

Outline

Mechanics

Kinematics

Arm robots

Inner-loop

Geometrical
model

Kinematic model

Dynamical
model

Conclusion

Path planning

Workspace and
obstacles

path planning

Mobile
robotics

Visual
servoing

RX90 robot

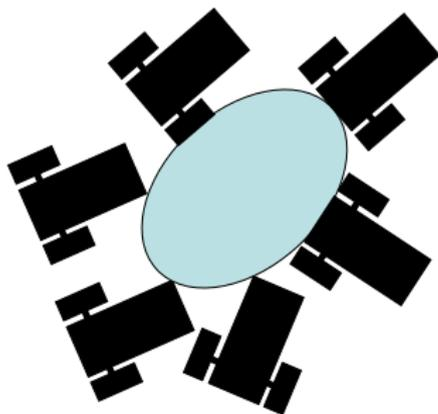



EXAMPLE: THE CAR

Robotics

N. Marchand

Introduction

Outline

Mechanics

Kinematics

Arm robots

Inner-loop

Geometrical
model

Kinematic model

Dynamical
model

Conclusion

Path planning

Workspace and
obstacles

path planning

Mobile
robotics

Visual
servoing

RX90 robot

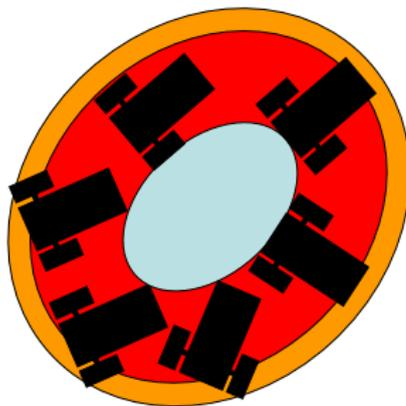



EXAMPLE: THE CAR

Robotics

N. Marchand

Introduction

Outline

Mechanics

Kinematics

Arm robots

Inner-loop

Geometrical
model

Kinematic model

Dynamical
model

Conclusion

Path planning

Workspace and
obstacles

path planning

Mobile
robotics

Visual
servoing

RX90 robot

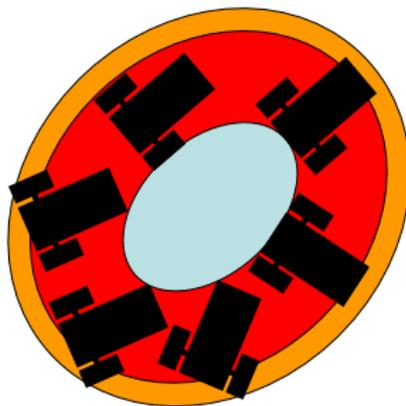

- The collision configuration subspace is the convex hull in which the robot and an obstacle make vertex to vertex contact



EXAMPLE: THE CAR

Robotics

N. Marchand

Introduction

Outline

Mechanics

Kinematics

Arm robots

Inner-loop

Geometrical
model

Kinematic model

Dynamical
model

Conclusion

Path planning

Workspace and
obstacles

path planning

Mobile
robotics

Visual
servoing

RX90 robot

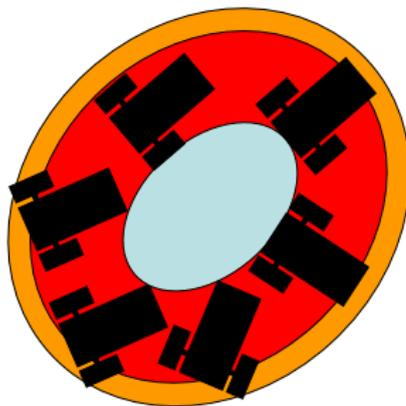

- The collision configuration subspace is the convex hull in which the robot and an obstacle make vertex to vertex contact
- Can be much more complicate to obtain



EXAMPLE: THE CAR

Robotics

N. Marchand

Introduction

Outline

Mechanics

Kinematics

Arm robots

Inner-loop

Geometrical
model

Kinematic model

Dynamical
model

Conclusion

Path planning

Workspace and
obstacles

path planning

Mobile
robotics

Visual
servoing

RX90 robot

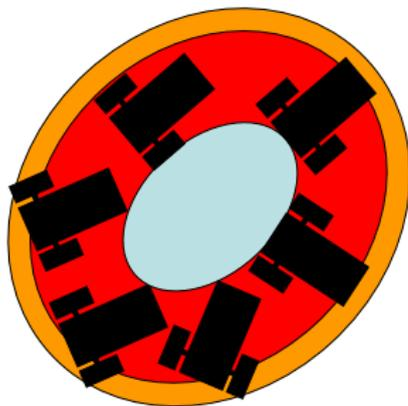

- The collision configuration subspace is the convex hull in which the robot and an obstacle make vertex to vertex contact
- Can be much more complicated to obtain
- Numerical simulation can easily solve this problem (systematic simulation)



EXAMPLE: ARM ROBOT

Robotics

N. Marchand

Introduction

Outline

Mechanics

Kinematics

Arm robots

Inner-loop

Geometrical
model

Kinematic model

Dynamical
model

Conclusion

Path planning

Workspace and
obstacles

path planning

Mobile
robotics

Visual
servoing

RX90 robot

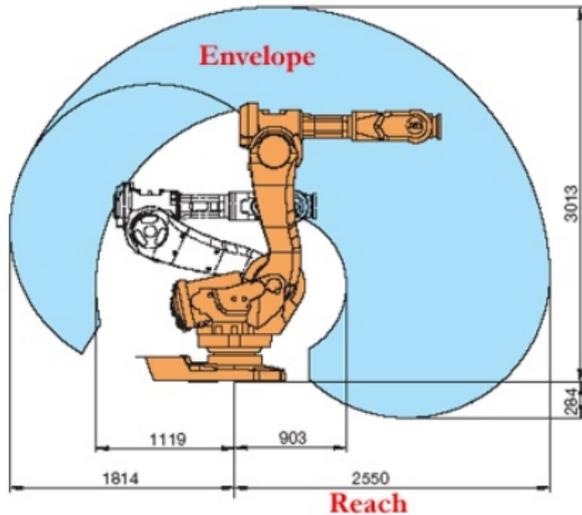

OUTLINE

Robotics

N. Marchand

Introduction

Outline

Mechanics

Kinematics

Arm robots

Inner-loop

Geometrical
model

Kinematic model

Dynamical
model

Conclusion

Path planning

Workspace and
obstacles

path planning

Mobile

robotics

Visual

servoing

RX90 robot

- 1 Introduction
- 2 Outline
- 3 Mechanics basis
- 4 Kinematics and dynamics of robots
 - Arm robots
 - Inner-loop
 - Geometrical model
 - Kinematic model
 - Dynamical model
 - Conclusion
- 5 Path planning**
 - Workspace and obstacles
 - Path planning problem formulation**
- 6 Mobile robotics
- 7 Visual servoing
- 8 Stäubli RX90 robot



A RECALL ON GRADIENT DESCENT

- $F(x, y) = \sin\left(\frac{1}{2}x^2 - \frac{1}{4}y^2 + 3\right) \cos(2x + 1 - e^y)$

Robotics

N. Marchand

Introduction

Outline

Mechanics

Kinematics

- Arm robots
- Inner-loop
- Geometrical model
- Kinematic model
- Dynamical model
- Conclusion

Path planning

- Workspace and obstacles
- path planning**

Mobile robotics

Visual servoing

RX90 robot



A RECALL ON GRADIENT DESCENT

Robotics

- $F(x, y) = \sin\left(\frac{1}{2}x^2 - \frac{1}{4}y^2 + 3\right) \cos(2x + 1 - e^y)$
- $z := (x, y), F(x, y) = F(z)$

N. Marchand

Introduction

Outline

Mechanics

Kinematics

Arm robots
Inner-loop
Geometrical
model
Kinematic model
Dynamical
model
Conclusion

Path planning

Workspace and
obstacles
path planning

Mobile
robotics

Visual
servoing

RX90 robot



A RECALL ON GRADIENT DESCENT

Robotics

N. Marchand

Introduction

Outline

Mechanics

Kinematics

Arm robots

Inner-loop

Geometrical
model

Kinematic model

Dynamical
model

Conclusion

Path planning

Workspace and
obstacles

path planning

Mobile

robotics

Visual

servoing

RX90 robot

- $F(x, y) = \sin\left(\frac{1}{2}x^2 - \frac{1}{4}y^2 + 3\right) \cos(2x + 1 - e^y)$
- $z := (x, y)$, $F(x, y) = F(z)$
- **Aim:** finding z^* such that $F(z^*)$ is minimum

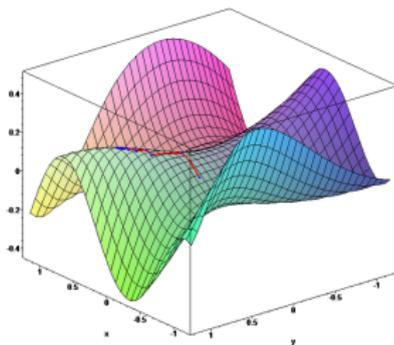



A RECALL ON GRADIENT DESCENT

Robotics

N. Marchand

Introduction

Outline

Mechanics

Kinematics

Arm robots

Inner-loop

Geometrical
model

Kinematic model

Dynamical
model

Conclusion

Path planning

Workspace and
obstacles

path planning

Mobile

robotics

Visual

servoing

RX90 robot

- $F(x, y) = \sin\left(\frac{1}{2}x^2 - \frac{1}{4}y^2 + 3\right) \cos(2x + 1 - e^y)$
- $z := (x, y)$, $F(x, y) = F(z)$
- **Aim:** finding z^* such that $F(z^*)$ is minimum

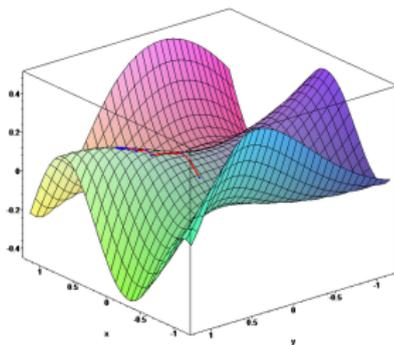

- Maximum/minimum obtained iteratively by :

$$z_{k+1} = z_k - \gamma \nabla F(z_k)$$



A RECALL ON GRADIENT DESCENT

Robotics

- $F(x, y) = \sin\left(\frac{1}{2}x^2 - \frac{1}{4}y^2 + 3\right) \cos(2x + 1 - e^y)$
- $z := (x, y)$, $F(x, y) = F(z)$
- **Aim:** finding z^* such that $F(z^*)$ is minimum

N. Marchand

Introduction

Outline

Mechanics

Kinematics

Arm robots
Inner-loop
Geometrical model
Kinematic model
Dynamical model
Conclusion

Path planning

Workspace and obstacles
path planning

Mobile robotics

Visual servoing

RX90 robot

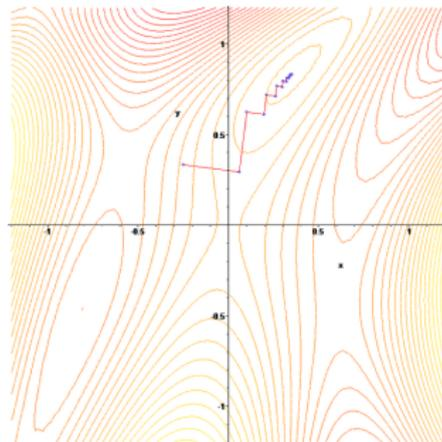
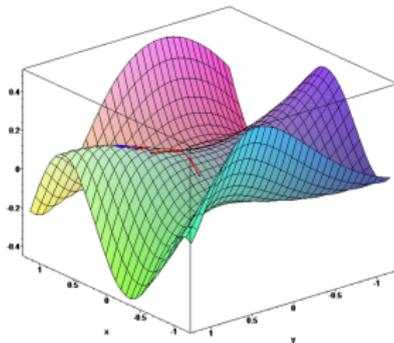

- Maximum/minimum obtained iteratively by :

$$z_{k+1} = z_k - \gamma \nabla F(z_k)$$

A RECALL ON GRADIENT DESCENT

About the stop criteria

Robotics

N. Marchand

Introduction

Outline

Mechanics

Kinematics

Arm robots

Inner-loop

Geometrical
model

Kinematic model

Dynamical
model

Conclusion

Path planning

Workspace and
obstacles

path planning

Mobile

robotics

Visual

servoing

RX90 robot

- Many solutions to stop the iteration

$$z_{k+1} = z_k - \gamma \nabla F(z_k)$$

A RECALL ON GRADIENT DESCENT

About the stop criteria

Robotics

N. Marchand

Introduction

Outline

Mechanics

Kinematics

Arm robots

Inner-loop

Geometrical
model

Kinematic model

Dynamical
model

Conclusion

Path planning

Workspace and
obstacles

path planning

Mobile

robotics

Visual

servoing

RX90 robot

- Many solutions to stop the iteration

$$z_{k+1} = z_k - \gamma \nabla F(z_k)$$

- Better from the criteria point of view:

stops if $F(z_{k+1}) > F(z_k)$

A RECALL ON GRADIENT DESCENT

About the stop criteria

Robotics

N. Marchand

Introduction

Outline

Mechanics

Kinematics

Arm robots

Inner-loop

Geometrical
model

Kinematic model

Dynamical
model

Conclusion

Path planning

Workspace and
obstacles

path planning

Mobile

robotics

Visual

servoing

RX90 robot

- Many solutions to stop the iteration

$$z_{k+1} = z_k - \gamma \nabla F(z_k)$$

- Better from the criteria point of view:

stops if $F(z_{k+1}) > F(z_k)$

- No more improvement in the criteria:

stops if $|F(z_{k+1}) - F(z_k)| < \varepsilon$



A RECALL ON GRADIENT DESCENT

About the stop criteria

Robotics

N. Marchand

Introduction

Outline

Mechanics

Kinematics

Arm robots

Inner-loop

Geometrical
model

Kinematic model

Dynamical
model

Conclusion

Path planning

Workspace and
obstacles

path planning

Mobile
robotics

Visual
servoing

RX90 robot

- Many solutions to stop the iteration

$$z_{k+1} = z_k - \gamma \nabla F(z_k)$$

- Better from the criteria point of view:

$$\text{stops if } F(z_{k+1}) > F(z_k)$$

- No more improvement in the criteria:

$$\text{stops if } |F(z_{k+1}) - F(z_k)| < \varepsilon$$

- No more slope (almost the same as previous condition)

$$\text{stops if } \|\nabla F(z_k)\| < \varepsilon$$

A RECALL ON GRADIENT DESCENT

About the step size γ

Robotics

N. Marchand

Introduction

Outline

Mechanics

Kinematics

Arm robots

Inner-loop

Geometrical
model

Kinematic model

Dynamical
model

Conclusion

Path planning

Workspace and
obstacles

path planning

Mobile

robotics

Visual

servoing

RX90 robot

- On the step size γ

A RECALL ON GRADIENT DESCENT

About the step size γ

Robotics

N. Marchand

Introduction

Outline

Mechanics

Kinematics

Arm robots
Inner-loop
Geometrical model
Kinematic model
Dynamical model
Conclusion

Path planning

Workspace and obstacles
path planning

Mobile robotics

Visual servoing

RX90 robot

- On the step size γ
- Newton-Euler method: H , Hessian of F

$$z_{k+1} = z_k - \nabla F(z_k) H(x_k)^{-1}$$

A RECALL ON GRADIENT DESCENT

About the step size γ

Robotics

N. Marchand

Introduction

Outline

Mechanics

Kinematics

- Arm robots
- Inner-loop
- Geometrical model
- Kinematic model
- Dynamical model
- Conclusion

Path planning

- Workspace and obstacles
- path planning

Mobile robotics

Visual servoing

RX90 robot

- On the step size γ
- Newton-Euler method: H , Hessian of F

$$z_{k+1} = z_k - \nabla F(z_k) H(x_k)^{-1}$$

- Quasi-Newton method:

$$z_{k+1} = z_k - \rho_k B_k \nabla F(z_k)$$

B_k : approximation of the Hessian

http://en.wikipedia.org/wiki/Quasi-Newton_method



PATH PLANNING PROBLEM FORMULATION

Robotics

- Want to go from one configuration θ_0 (position) to another one θ_f

N. Marchand

Introduction

Outline

Mechanics

Kinematics

Arm robots
Inner-loop
Geometrical
model
Kinematic model
Dynamical
model
Conclusion

Path planning

Workspace and
obstacles
path planning

Mobile
robotics

Visual
servoing

RX90 robot

PATH PLANNING PROBLEM FORMULATION

Robotics

- Want to go from one configuration θ_0 (position) to another one θ_f

- We define a continuous function $\gamma : [0, 1] \rightarrow Q_f$ such that

N. Marchand

Introduction

Outline

Mechanics

Kinematics

- Arm robots
- Inner-loop
- Geometrical model
- Kinematic model
- Dynamical model
- Conclusion

Path planning

- Workspace and obstacles
- path planning**

Mobile robotics

Visual servoing

RX90 robot



PATH PLANNING PROBLEM FORMULATION

Robotics

N. Marchand

Introduction

Outline

Mechanics

Kinematics

Arm robots

Inner-loop

Geometrical
model

Kinematic model

Dynamical
model

Conclusion

Path planning

Workspace and
obstacles

path planning

Mobile robotics

Visual servoing

RX90 robot

- Want to go from one configuration θ_0 (position) to another one θ_f
- We define a continuous function $\gamma : [0, 1] \rightarrow Q_f$ such that
 - $\gamma(0) = \theta_0$ and $\gamma(1) = \theta_f$



PATH PLANNING PROBLEM FORMULATION

Robotics

N. Marchand

Introduction

Outline

Mechanics

Kinematics

- Arm robots
- Inner-loop
- Geometrical model
- Kinematic model
- Dynamical model
- Conclusion

Path planning

- Workspace and obstacles
- path planning**

Mobile robotics

Visual servoing

RX90 robot

- Want to go from one configuration θ_0 (position) to another one θ_f
- We define a continuous function $\gamma : [0, 1] \rightarrow Q_f$ such that
 - $\gamma(0) = \theta_0$ and $\gamma(1) = \theta_f$
- γ will represent a configuration between the initial configuration and the final

PATH PLANNING PROBLEM FORMULATION

Robotics

N. Marchand

Introduction

Outline

Mechanics

Kinematics

- Arm robots
- Inner-loop
- Geometrical model
- Kinematic model
- Dynamical model
- Conclusion

Path planning

- Workspace and obstacles
- path planning**

Mobile robotics

Visual servoing

RX90 robot

- Want to go from one configuration θ_0 (position) to another one θ_f
- We define a continuous function $\gamma : [0, 1] \rightarrow Q_f$ such that
 - $\gamma(0) = \theta_0$ and $\gamma(1) = \theta_f$
- γ will represent a configuration between the initial configuration and the final
- The aim will be to find successive γ that remain in Q_f :

$\tau \rightarrow \gamma(\tau)$ is a path from θ_0 to θ_f



PATH PLANNING PROBLEM FORMULATION

Robotics

N. Marchand

Introduction

Outline

Mechanics

Kinematics

Arm robots

Inner-loop

Geometrical
model

Kinematic model

Dynamical
model

Conclusion

Path planning

Workspace and
obstacles

path planning

Mobile

robotics

Visual

servoing

RX90 robot

- Want to go from one configuration θ_0 (position) to another one θ_f
- We define a continuous function $\gamma : [0, 1] \rightarrow Q_f$ such that
 - $\gamma(0) = \theta_0$ and $\gamma(1) = \theta_f$
- γ will represent a configuration between the initial configuration and the final
- The aim will be to find successive γ that remain in Q_f :

$\tau \rightarrow \gamma(\tau)$ is a path from θ_0 to θ_f
- We define a potential field (criterion):

$$U(\theta) = U_{att}(\theta) + U_{rep}(\theta)$$

The aim will be to minimize the criterion



PATH PLANNING PROBLEM FORMULATION

Robotics

N. Marchand

Introduction

Outline

Mechanics

Kinematics

Arm robots
Inner-loop
Geometrical
model
Kinematic model
Dynamical
model
Conclusion

Path planning

Workspace and
obstacles
path planning

Mobile
robotics

Visual
servoing

RX90 robot

- Want to go from one configuration θ_0 (position) to another one θ_f
- We define a continuous function $\gamma : [0, 1] \rightarrow Q_f$ such that
 - $\gamma(0) = \theta_0$ and $\gamma(1) = \theta_f$
- γ will represent a configuration between the initial configuration and the final
- The aim will be to find successive γ that remain in Q_f :

$\tau \rightarrow \gamma(\tau)$ is a path from θ_0 to θ_f
- We define a potential field (criterion):

$$U(\theta) = U_{att}(\theta) + U_{rep}(\theta)$$

- $U_{att}(\theta)$ will attract γ to θ_f : the goal configuration

The aim will be to minimize the criterion



PATH PLANNING PROBLEM FORMULATION

Robotics

N. Marchand

Introduction

Outline

Mechanics

Kinematics

Arm robots
Inner-loop
Geometrical model
Kinematic model
Dynamical model
Conclusion

Path planning

Workspace and obstacles
path planning

Mobile robotics

Visual servoing

RX90 robot

- Want to go from one configuration θ_0 (position) to another one θ_f
- We define a continuous function $\gamma : [0, 1] \rightarrow Q_f$ such that
 - $\gamma(0) = \theta_0$ and $\gamma(1) = \theta_f$
- γ will represent a configuration between the initial configuration and the final
- The aim will be to find successive γ that remain in Q_f :

$\tau \rightarrow \gamma(\tau)$ is a path from θ_0 to θ_f
- We define a potential field (criterion):

$$U(\theta) = U_{att}(\theta) + U_{rep}(\theta)$$

- $U_{att}(\theta)$ will attract γ to θ_f : the goal configuration
- $U_{rep}(\theta)$ will repulse the system away from obstacle

The aim will be to minimize the criterion

SIMPLE EXEMPLE OF OBJECTIVE FUNCTION

Robotics

N. Marchand

Introduction

Outline

Mechanics

Kinematics

- Arm robots
- Inner-loop
- Geometrical model
- Kinematic model
- Dynamical model
- Conclusion

Path planning

- Workspace and obstacles
- path planning**

Mobile robotics

Visual servoing

RX90 robot

- Take $U_{att}(\theta) = \|\theta - \theta_f\|$: U_{att} is the distance to the final destination

SIMPLE EXEMPLE OF OBJECTIVE FUNCTION

Robotics

N. Marchand

Introduction

Outline

Mechanics

Kinematics

- Arm robots
- Inner-loop
- Geometrical model
- Kinematic model
- Dynamical model
- Conclusion

Path planning

- Workspace and obstacles
- path planning**

Mobile robotics

Visual servoing

RX90 robot

- Take $U_{att}(\theta) = \|\theta - \theta_f\|$: U_{att} is the distance to the final destination
- Take $U_{rep}(\theta) = \frac{1}{d(\theta, Q_c)}$: U_{rep} is infinite if there is a risk of obstacle



ATTRACTIVE/REPULSIVE FIELDS

Robotics

N. Marchand

Introduction

Outline

Mechanics

Kinematics

Arm robots
Inner-loop
Geometrical
model
Kinematic model
Dynamical
model
Conclusion

Path planning

Workspace and
obstacles
path planning

Mobile
robotics

Visual
servoing

RX90 robot

- Trying to minimize or maximize the distance is not necessary appropriate

ATTRACTIVE/REPULSIVE FIELDS

Robotics

N. Marchand

Introduction

Outline

Mechanics

Kinematics

- Arm robots
- Inner-loop
- Geometrical model
- Kinematic model
- Dynamical model
- Conclusion

Path planning

- Workspace and obstacles
- path planning**

Mobile robotics

Visual servoing

RX90 robot

- Trying to minimize or maximize the distance is not necessary appropriate
- Inappropriate criterium may:

ATTRACTIVE/REPULSIVE FIELDS

Robotics

N. Marchand

Introduction

Outline

Mechanics

Kinematics

- Arm robots
- Inner-loop
- Geometrical model
- Kinematic model
- Dynamical model
- Conclusion

Path planning

- Workspace and obstacles
- path planning**

Mobile robotics

Visual servoing

RX90 robot

- Trying to minimize or maximize the distance is not necessary appropriate
- Inappropriate criterium may:
 - generate local minima

ATTRACTIVE/REPULSIVE FIELDS

Robotics

N. Marchand

Introduction

Outline

Mechanics

Kinematics

- Arm robots
- Inner-loop
- Geometrical model
- Kinematic model
- Dynamical model
- Conclusion

Path planning

- Workspace and obstacles
- path planning**

Mobile robotics

Visual servoing

RX90 robot

- Trying to minimize or maximize the distance is not necessary appropriate
- Inappropriate criterium may:
 - generate local minima
 - be delicate to minimize

ATTRACTIVE/REPULSIVE FIELDS

Robotics

N. Marchand

Introduction

Outline

Mechanics

Kinematics

Arm robots
Inner-loop
Geometrical
model
Kinematic model
Dynamical
model
Conclusion

Path planning

Workspace and
obstacles
path planning

Mobile
robotics

Visual
servoing

RX90 robot

- Trying to minimize or maximize the distance is not necessary appropriate
- Inappropriate criterium may:
 - generate local minima
 - be delicate to minimize
 - have singularities

ATTRACTIVE/REPULSIVE FIELDS

Robotics

N. Marchand

Introduction

Outline

Mechanics

Kinematics

Arm robots
Inner-loop
Geometrical model
Kinematic model
Dynamical model
Conclusion

Path planning

Workspace and obstacles
path planning

Mobile robotics

Visual servoing

RX90 robot

- Trying to minimize or maximize the distance is not necessary appropriate
- Inappropriate criterium may:
 - generate local minima
 - be delicate to minimize
 - have singularities
- **The main problem consist in finding a criterium that will be convex (or close to)**

MANIPULATOR ROBOTS

Robotics

N. Marchand

Introduction

Outline

Mechanics

Kinematics

- Arm robots
- Inner-loop
- Geometrical model
- Kinematic model
- Dynamical model
- Conclusion

Path planning

- Workspace and obstacles
- path planning**

Mobile robotics

Visual servoing

RX90 robot

- We define a potential field for each articulation

MANIPULATOR ROBOTS

Robotics

N. Marchand

Introduction

Outline

Mechanics

Kinematics

- Arm robots
- Inner-loop
- Geometrical model
- Kinematic model
- Dynamical model
- Conclusion

Path planning

- Workspace and obstacles
- path planning**

Mobile robotics

Visual servoing

RX90 robot

- We define a potential field for each articulation
- The attractive field is a monotonically increasing function of the distance of the i^{th} frame to the goal position

MANIPULATOR ROBOTS

Robotics

N. Marchand

Introduction

Outline

Mechanics

Kinematics

- Arm robots
- Inner-loop
- Geometrical model
- Kinematic model
- Dynamical model
- Conclusion

Path planning

- Workspace and obstacles
- path planning**

Mobile robotics

Visual servoing

RX90 robot

- We define a potential field for each articulation
- The attractive field is a monotonically increasing function of the distance of the i^{th} frame to the goal position
- The attractive field applies a fictitious force that push the manipulator into its goal position



MANIPULATOR ROBOTS

Robotics

N. Marchand

Introduction

Outline

Mechanics

Kinematics

Arm robots
Inner-loop
Geometrical
model
Kinematic model
Dynamical
model
Conclusion

Path planning

Workspace and
obstacles
path planning

Mobile
robotics

Visual
servoing

RX90 robot

- We define a potential field for each articulation
- The attractive field is a monotonically increasing function of the distance of the i^{th} frame to the goal position
- The attractive field applies a fictitious force that push the manipulator into its goal position
- The repulsive field will create a fictitious force that will prevent collisions by repelling the robot from the obstacles



ATTRACTIVE FIELDS

Robotics

N. Marchand

Introduction

Outline

Mechanics

Kinematics

Arm robots

Inner-loop

Geometrical
model

Kinematic model

Dynamical
model

Conclusion

Path planning

Workspace and
obstacles

path planning

Mobile
robotics

Visual
servoing

RX90 robot

- Simple potential field: *conic well potential*

$$U_{att_i}(\theta) = \zeta_i \|O_i(\theta) - O_i(\theta_f)\|$$

ATTRACTIVE FIELDS

Robotics

N. Marchand

Introduction

Outline

Mechanics

Kinematics

Arm robots

Inner-loop

Geometrical
model

Kinematic model

Dynamical
model

Conclusion

Path planning

Workspace and
obstacles

path planning

Mobile robotics

Visual servoing

RX90 robot

- Simple potential field: *conic well potential*

$$U_{att_i}(\theta) = \zeta_i \|O_i(\theta) - O_i(\theta_f)\|$$

- The corresponding force is:

$$F_{att_i}(\theta) = -\zeta_i \nabla \|O_i(\theta) - O_i(\theta_f)\| = -\zeta_i \frac{O_i(\theta) - O_i(\theta_f)}{\|O_i(\theta) - O_i(\theta_f)\|}$$

ATTRACTIVE FIELDS

Robotics

N. Marchand

Introduction

Outline

Mechanics

Kinematics

Arm robots

Inner-loop

Geometrical
model

Kinematic model

Dynamical
model

Conclusion

Path planning

Workspace and
obstacles

path planning

Mobile
roboticsVisual
servoing

RX90 robot

- Simple potential field: *conic well potential*

$$U_{att_i}(\theta) = \zeta_i \|O_i(\theta) - O_i(\theta_f)\|$$

- The corresponding force is:

$$F_{att_i}(\theta) = -\zeta_i \nabla \|O_i(\theta) - O_i(\theta_f)\| = -\zeta_i \frac{O_i(\theta) - O_i(\theta_f)}{\|O_i(\theta) - O_i(\theta_f)\|}$$

- it is a ζ_i -norm vector pointing to the objective

ATTRACTIVE FIELDS

Robotics

N. Marchand

Introduction

Outline

Mechanics

Kinematics

- Arm robots
- Inner-loop
- Geometrical model
- Kinematic model
- Dynamical model
- Conclusion

Path planning

- Workspace and obstacles
- path planning

 Mobile
robotics

 Visual
servoing

RX90 robot

- Simple potential field: *conic well potential*

$$U_{att_i}(\theta) = \zeta_i \|O_i(\theta) - O_i(\theta_f)\|$$

- The corresponding force is:

$$F_{att_i}(\theta) = -\zeta_i \nabla \|O_i(\theta) - O_i(\theta_f)\| = -\zeta_i \frac{O_i(\theta) - O_i(\theta_f)}{\|O_i(\theta) - O_i(\theta_f)\|}$$

- it is a ζ_i -norm vector pointing to the objective
- has a singularity at the objective

ATTRACTIVE FIELDS

Robotics

N. Marchand

Introduction

Outline

Mechanics

Kinematics

Arm robots
 Inner-loop
 Geometrical
 model
 Kinematic model
 Dynamical
 model
 Conclusion

Path planning

Workspace and
 obstacles
 path planning

Mobile
 robotics

Visual
 servoing

RX90 robot

- Simple potential field: *conic well potential*

$$U_{att_i}(\theta) = \zeta_i \|O_i(\theta) - O_i(\theta_f)\|$$

- The corresponding force is:

$$F_{att_i}(\theta) = -\zeta_i \nabla \|O_i(\theta) - O_i(\theta_f)\| = -\zeta_i \frac{O_i(\theta) - O_i(\theta_f)}{\|O_i(\theta) - O_i(\theta_f)\|}$$

- it is a ζ_i -norm vector pointing to the objective
- has a singularity at the objective
- ζ_i is a ponderation between articulations

ATTRACTIVE FIELDS

Robotics

- Instead we use: *parabolic well potential*

$$U_{att_i}(\theta) = \frac{1}{2}\zeta_i \|O_i(\theta) - O_i(\theta_f)\|^2$$

N. Marchand

Introduction

Outline

Mechanics

Kinematics

Arm robots

Inner-loop

Geometrical
model

Kinematic model

Dynamical
model

Conclusion

Path planning

Workspace and
obstacles

path planning

Mobile
robotics

Visual
servoing

RX90 robot



ATTRACTIVE FIELDS

Robotics

- Instead we use: *parabolic well potential*

$$U_{att_i}(\theta) = \frac{1}{2}\zeta_i \|O_i(\theta) - O_i(\theta_f)\|^2$$

- The corresponding force is:

$$F_{att_i}(\theta) = -\nabla \|O_i(\theta) - O_i(\theta_f)\| = -\zeta_i(O_i(\theta) - O_i(\theta_f))$$

N. Marchand

Introduction

Outline

Mechanics

Kinematics

Arm robots

Inner-loop

Geometrical
model

Kinematic model

Dynamical
model

Conclusion

Path planning

Workspace and
obstacles

path planning

Mobile

robotics

Visual

servoing

RX90 robot



ATTRACTIVE FIELDS

Robotics

- Instead we use: *parabolic well potential*

$$U_{att_i}(\theta) = \frac{1}{2} \zeta_i \|O_i(\theta) - O_i(\theta_f)\|^2$$

- The corresponding force is:

$$F_{att_i}(\theta) = -\nabla \|O_i(\theta) - O_i(\theta_f)\| = -\zeta_i (O_i(\theta) - O_i(\theta_f))$$

- this force is defined everywhere

N. Marchand

Introduction

Outline

Mechanics

Kinematics

Arm robots

Inner-loop

Geometrical
model

Kinematic model

Dynamical
model

Conclusion

Path planning

Workspace and
obstacles

path planning

Mobile

robotics

Visual

servoing

RX90 robot

ATTRACTIVE FIELDS

Robotics

- Instead we use: *parabolic well potential*

$$U_{att_i}(\theta) = \frac{1}{2} \zeta_i \|O_i(\theta) - O_i(\theta_f)\|^2$$

- The corresponding force is:

$$F_{att_i}(\theta) = -\nabla \|O_i(\theta) - O_i(\theta_f)\| = -\zeta_i (O_i(\theta) - O_i(\theta_f))$$

- this force is defined everywhere
- Or the hybrid potential:

N. Marchand

Introduction

Outline

Mechanics

Kinematics

 Arm robots
 Inner-loop
 Geometrical model
 Kinematic model
 Dynamical model
 Conclusion

Path planning

 Workspace and obstacles
 path planning

Mobile robotics

Visual servoing

RX90 robot



ATTRACTIVE FIELDS

Robotics

- Instead we use: *parabolic well potential*

$$U_{att_i}(\theta) = \frac{1}{2}\zeta_i \|O_i(\theta) - O_i(\theta_f)\|^2$$

- The corresponding force is:

$$F_{att_i}(\theta) = -\nabla \|O_i(\theta) - O_i(\theta_f)\| = -\zeta_i(O_i(\theta) - O_i(\theta_f))$$

- this force is defined everywhere
- Or the hybrid potential:
 - $U_{att_i}(\theta) = \frac{1}{2}\zeta_i \|O_i(\theta) - O_i(\theta_f)\|^2$ if $\|O_i(\theta) - O_i(\theta_f)\| \leq d$

N. Marchand

Introduction

Outline

Mechanics

Kinematics

Arm robots

Inner-loop

Geometrical
model

Kinematic model

Dynamical
model

Conclusion

Path planning

Workspace and
obstacles

path planning

Mobile

robotics

Visual

servoing

RX90 robot

ATTRACTIVE FIELDS

Robotics

- Instead we use: *parabolic well potential*

$$U_{att_i}(\theta) = \frac{1}{2}\zeta_i \|O_i(\theta) - O_i(\theta_f)\|^2$$

- The corresponding force is:

$$F_{att_i}(\theta) = -\nabla \|O_i(\theta) - O_i(\theta_f)\| = -\zeta_i(O_i(\theta) - O_i(\theta_f))$$

- this force is defined everywhere
- Or the hybrid potential:

- $U_{att_i}(\theta) = \frac{1}{2}\zeta_i \|O_i(\theta) - O_i(\theta_f)\|^2$ if $\|O_i(\theta) - O_i(\theta_f)\| \leq d$
- $U_{att_i}(\theta) = -d\zeta_i \|O_i(\theta) - O_i(\theta_f)\| - \frac{1}{2}\zeta_i d^2$ if $\|O_i(\theta) - O_i(\theta_f)\| \leq d$

N. Marchand

Introduction

Outline

Mechanics

Kinematics

Arm robots

Inner-loop

Geometrical
model

Kinematic model

Dynamical
model

Conclusion

Path planning

Workspace and
obstacles

path planning

Mobile
roboticsVisual
servoing

RX90 robot

ATTRACTIVE FIELDS

Robotics

- Instead we use: *parabolic well potential*

$$U_{att_i}(\theta) = \frac{1}{2}\zeta_i \|O_i(\theta) - O_i(\theta_f)\|^2$$

- The corresponding force is:

$$F_{att_i}(\theta) = -\nabla \|O_i(\theta) - O_i(\theta_f)\| = -\zeta_i(O_i(\theta) - O_i(\theta_f))$$

- this force is defined everywhere
- Or the hybrid potential:
 - $U_{att_i}(\theta) = \frac{1}{2}\zeta_i \|O_i(\theta) - O_i(\theta_f)\|^2$ if $\|O_i(\theta) - O_i(\theta_f)\| \leq d$
 - $U_{att_i}(\theta) = -d\zeta_i \|O_i(\theta) - O_i(\theta_f)\| - \frac{1}{2}\zeta_i d^2$ if $\|O_i(\theta) - O_i(\theta_f)\| \leq d$
- The corresponding force is:

N. Marchand

Introduction

Outline

Mechanics

Kinematics

Arm robots

Inner-loop

Geometrical model

Kinematic model

Dynamical model

Conclusion

Path planning

Workspace and obstacles

path planning

Mobile

robotics

Visual

servoing

RX90 robot



ATTRACTIVE FIELDS

Robotics

- Instead we use: *parabolic well potential*

$$U_{att_i}(\theta) = \frac{1}{2}\zeta_i \|O_i(\theta) - O_i(\theta_f)\|^2$$

- The corresponding force is:

$$F_{att_i}(\theta) = -\nabla \|O_i(\theta) - O_i(\theta_f)\| = -\zeta_i(O_i(\theta) - O_i(\theta_f))$$

- this force is defined everywhere
- Or the hybrid potential:
 - $U_{att_i}(\theta) = \frac{1}{2}\zeta_i \|O_i(\theta) - O_i(\theta_f)\|^2$ if $\|O_i(\theta) - O_i(\theta_f)\| \leq d$
 - $U_{att_i}(\theta) = -d\zeta_i \|O_i(\theta) - O_i(\theta_f)\| - \frac{1}{2}\zeta_i d^2$ if $\|O_i(\theta) - O_i(\theta_f)\| \leq d$
- The corresponding force is:
 - $F_{att_i}(\theta) = -\zeta_i(O_i(\theta) - O_i(\theta_f))$ if $\|O_i(\theta) - O_i(\theta_f)\| \leq d$

N. Marchand

Introduction

Outline

Mechanics

Kinematics

Arm robots

Inner-loop

Geometrical
model

Kinematic model

Dynamical
model

Conclusion

Path planning

Workspace and
obstacles

path planning

Mobile

robotics

Visual

servoing

RX90 robot



ATTRACTIVE FIELDS

Robotics

- Instead we use: *parabolic well potential*

$$U_{att_i}(\theta) = \frac{1}{2}\zeta_i \|O_i(\theta) - O_i(\theta_f)\|^2$$

N. Marchand

Introduction

Outline

Mechanics

Kinematics

Arm robots

Inner-loop

Geometrical
model

Kinematic model

Dynamical
model

Conclusion

Path planning

Workspace and
obstacles

path planning

Mobile

robotics

Visual

servoing

RX90 robot

- The corresponding force is:

$$F_{att_i}(\theta) = -\nabla \|O_i(\theta) - O_i(\theta_f)\| = -\zeta_i(O_i(\theta) - O_i(\theta_f))$$

- this force is defined everywhere
- Or the hybrid potential:
 - $U_{att_i}(\theta) = \frac{1}{2}\zeta_i \|O_i(\theta) - O_i(\theta_f)\|^2$ if $\|O_i(\theta) - O_i(\theta_f)\| \leq d$
 - $U_{att_i}(\theta) = -d\zeta_i \|O_i(\theta) - O_i(\theta_f)\| - \frac{1}{2}\zeta_i d^2$ if $\|O_i(\theta) - O_i(\theta_f)\| \leq d$
- The corresponding force is:
 - $F_{att_i}(\theta) = -\zeta_i(O_i(\theta) - O_i(\theta_f))$ if $\|O_i(\theta) - O_i(\theta_f)\| \leq d$
 - $F_{att_i}(\theta) = -d\zeta_i \frac{O_i(\theta) - O_i(\theta_f)}{\|O_i(\theta) - O_i(\theta_f)\|}$ if $\|O_i(\theta) - O_i(\theta_f)\| \leq d$



REPULSIVE FIELDS

Robotics

N. Marchand

- Again, one repulsive field by articulation is given

Introduction

Outline

Mechanics

Kinematics

Arm robots
Inner-loop
Geometrical
model
Kinematic model
Dynamical
model
Conclusion

Path planning

Workspace and
obstacles
path planning

Mobile
robotics

Visual
servoing

RX90 robot

REPULSIVE FIELDS

Robotics

N. Marchand

- Again, one repulsive field by articulation is given
- Should *strongly* repel the robot close to obstacles

Introduction

Outline

Mechanics

Kinematics

Arm robots
Inner-loop
Geometrical
model
Kinematic model
Dynamical
model
Conclusion

Path planning

Workspace and
obstacles
path planning

Mobile
robotics

Visual
servoing

RX90 robot

REPULSIVE FIELDS

Robotics

N. Marchand

Introduction

Outline

Mechanics

Kinematics

- Arm robots
- Inner-loop
- Geometrical model
- Kinematic model
- Dynamical model
- Conclusion

Path planning

- Workspace and obstacles
- path planning**

Mobile robotics

Visual servoing

RX90 robot

- Again, one repulsive field by articulation is given
- Should *strongly* repel the robot close to obstacles
- Usually, should not have any influence far from the obstacle

REPULSIVE FIELDS

Robotics

N. Marchand

Introduction

Outline

Mechanics

Kinematics

Arm robots
Inner-loop
Geometrical
model
Kinematic model
Dynamical
model
Conclusion

Path planning

Workspace and
obstacles
path planning

Mobile
robotics

Visual
servoing

RX90 robot

- Again, one repulsive field by articulation is given
- Should *strongly* repel the robot close to obstacles
- Usually, should not have any influence far from the obstacle
- First define a radius of influence ρ_i

REPULSIVE FIELDS

Robotics

N. Marchand

Introduction

Outline

Mechanics

Kinematics

Arm robots
Inner-loop
Geometrical model
Kinematic model
Dynamical model
Conclusion

Path planning

Workspace and obstacles
path planning

Mobile robotics

Visual servoing

RX90 robot

- Again, one repulsive field by articulation is given
- Should *strongly* repel the robot close to obstacles
- Usually, should not have any influence far from the obstacle
- First define a radius of influence ρ_i
- Define the repulsive field:



REPULSIVE FIELDS

Robotics

N. Marchand

Introduction

Outline

Mechanics

Kinematics

Arm robots
 Inner-loop
 Geometrical model
 Kinematic model
 Dynamical model
 Conclusion

Path planning

Workspace and obstacles
 path planning

Mobile robotics

Visual servoing

RX90 robot

- Again, one repulsive field by articulation is given
- Should *strongly* repel the robot close to obstacles
- Usually, should not have any influence far from the obstacle
- First define a radius of influence ρ_i
- Define the repulsive field:
 - $U_{rep_i}(\theta) = 0$ if $d(\theta, O) < \rho_i$



REPULSIVE FIELDS

Robotics

N. Marchand

Introduction

Outline

Mechanics

Kinematics

Arm robots

Inner-loop

Geometrical
model

Kinematic model

Dynamical
model

Conclusion

Path planning

Workspace and
obstacles

path planning

Mobile

robotics

Visual

servoing

RX90 robot

- Again, one repulsive field by articulation is given
- Should *strongly* repel the robot close to obstacles
- Usually, should not have any influence far from the obstacle
- First define a radius of influence ρ_i
- Define the repulsive field:
 - $U_{rep_i}(\theta) = 0$ if $d(\theta, O) < \rho_i$
 - $U_{rep_i}(\theta) = \frac{\zeta_i}{2} \left(\frac{1}{d(\theta, O)} - \frac{1}{\rho_0} \right)^2$ if $d(\theta, O) \geq \rho_i$



REPULSIVE FIELDS

Robotics

N. Marchand

Introduction

Outline

Mechanics

Kinematics

- Arm robots
- Inner-loop
- Geometrical model
- Kinematic model
- Dynamical model
- Conclusion

Path planning

- Workspace and obstacles
- path planning

Mobile robotics

Visual servoing

RX90 robot

- Again, one repulsive field by articulation is given
- Should *strongly* repel the robot close to obstacles
- Usually, should not have any influence far from the obstacle
- First define a radius of influence ρ_i
- Define the repulsive field:
 - $U_{rep_i}(\theta) = 0$ if $d(\theta, O) < \rho_i$
 - $U_{rep_i}(\theta) = \frac{\zeta_i}{2} \left(\frac{1}{d(\theta, O)} - \frac{1}{\rho_0} \right)^2$ if $d(\theta, O) \geq \rho_i$
- The corresponding fictive force is:



REPULSIVE FIELDS

Robotics

N. Marchand

Introduction

Outline

Mechanics

Kinematics

Arm robots

Inner-loop

Geometrical
model

Kinematic model

Dynamical
model

Conclusion

Path planning

Workspace and
obstacles

path planning

Mobile

robotics

Visual

servoing

RX90 robot

- Again, one repulsive field by articulation is given
- Should *strongly* repel the robot close to obstacles
- Usually, should not have any influence far from the obstacle
- First define a radius of influence ρ_i
- Define the repulsive field:
 - $U_{rep_i}(\theta) = 0$ if $d(\theta, O) < \rho_i$
 - $U_{rep_i}(\theta) = \frac{\zeta_i}{2} \left(\frac{1}{d(\theta, O)} - \frac{1}{\rho_0} \right)^2$ if $d(\theta, O) \geq \rho_i$
- The corresponding fictive force is:
 - $F_{rep_i}(\theta) = 0$ if $d(\theta, O) < \rho_i$



REPULSIVE FIELDS

Robotics

N. Marchand

Introduction

Outline

Mechanics

Kinematics

Arm robots

Inner-loop

Geometrical
model

Kinematic model

Dynamical
model

Conclusion

Path planning

Workspace and
obstacles

path planning

Mobile

robotics

Visual

servoing

RX90 robot

- Again, one repulsive field by articulation is given
- Should *strongly* repel the robot close to obstacles
- Usually, should not have any influence far from the obstacle
- First define a radius of influence ρ_i
- Define the repulsive field:
 - $U_{rep_i}(\theta) = 0$ if $d(\theta, O) < \rho_i$
 - $U_{rep_i}(\theta) = \frac{\zeta_i}{2} \left(\frac{1}{d(\theta, O)} - \frac{1}{\rho_0} \right)^2$ if $d(\theta, O) \geq \rho_i$
- The corresponding fictive force is:
 - $F_{rep_i}(\theta) = 0$ if $d(\theta, O) < \rho_i$
 - $F_{rep_i}(\theta) = -\zeta_i \left(\frac{1}{d(\theta, O)} - \frac{1}{\rho_0} \right) d(\theta, O)^{-2} \nabla d(\theta, O)$ if $d(\theta, O) \geq \rho_i$



FROM ATTRACTIVE/REPULSIVE FORCES TO ACTUATOR TORQUES

Robotics

N. Marchand

Introduction

Outline

Mechanics

Kinematics

- Arm robots
- Inner-loop
- Geometrical model
- Kinematic model
- Dynamical model
- Conclusion

Path planning

- Workspace and obstacles
- path planning

Mobile robotics

Visual servoing

RX90 robot

- The total joint torques acting on a robot is the sum of the torques from all attractive and repulsive potentials:

$$\tau(\theta) = \sum_i J_{O_i}^T(\theta) (F_{att_i}(\theta) + F_{rep_i}(\theta))$$

GRADIENT DESCENT

Robotics

N. Marchand

Introduction

Outline

Mechanics

Kinematics

Arm robots

Inner-loop

Geometrical
model

Kinematic model

Dynamical
model

Conclusion

Path planning

Workspace and
obstacles

path planning

Mobile

robotics

Visual

servoing

RX90 robot

- Now that we can formulate the total torques acting on the joints in the configuration space due to the artificial potentials, we can formulate a path planning algorithm

GRADIENT DESCENT

Robotics

N. Marchand

Introduction

Outline

Mechanics

Kinematics

- Arm robots
- Inner-loop
- Geometrical model
- Kinematic model
- Dynamical model
- Conclusion

Path planning

- Workspace and obstacles
- path planning**

Mobile robotics

Visual servoing

RX90 robot

- Now that we can formulate the total torques acting on the joints in the configuration space due to the artificial potentials, we can formulate a path planning algorithm
 - 1 First, determine your initial configuration

GRADIENT DESCENT

Robotics

N. Marchand

Introduction

Outline

Mechanics

Kinematics

- Arm robots
- Inner-loop
- Geometrical model
- Kinematic model
- Dynamical model
- Conclusion

Path planning

- Workspace and obstacles
- path planning

Mobile robotics

Visual servoing

RX90 robot

- Now that we can formulate the total torques acting on the joints in the configuration space due to the artificial potentials, we can formulate a path planning algorithm
 - 1 First, determine your initial configuration
 - 2 Second, given a desired point in the workspace, calculate the final configuration using the inverse kinematics: Use this to create an attractive potential field

GRADIENT DESCENT

Robotics

N. Marchand

Introduction

Outline

Mechanics

Kinematics

- Arm robots
- Inner-loop
- Geometrical model
- Kinematic model
- Dynamical model
- Conclusion

Path planning

- Workspace and obstacles
- path planning

Mobile robotics

Visual servoing

RX90 robot

- Now that we can formulate the total torques acting on the joints in the configuration space due to the artificial potentials, we can formulate a path planning algorithm
 - 1 First, determine your initial configuration
 - 2 Second, given a desired point in the workspace, calculate the final configuration using the inverse kinematics: Use this to create an attractive potential field
 - 3 Locate obstacles in the workspace: Create a repulsive potential field

GRADIENT DESCENT

Robotics

N. Marchand

Introduction

Outline

Mechanics

Kinematics

- Arm robots
- Inner-loop
- Geometrical model
- Kinematic model
- Dynamical model
- Conclusion

Path planning

- Workspace and obstacles
- path planning

Mobile robotics

Visual servoing

RX90 robot

- Now that we can formulate the total torques acting on the joints in the configuration space due to the artificial potentials, we can formulate a path planning algorithm
 - First, determine your initial configuration
 - Second, given a desired point in the workspace, calculate the final configuration using the inverse kinematics: Use this to create an attractive potential field
 - Locate obstacles in the workspace: Create a repulsive potential field
 - Sum the joint torques in the configuration space

GRADIENT DESCENT

Robotics

N. Marchand

Introduction

Outline

Mechanics

Kinematics

- Arm robots
- Inner-loop
- Geometrical model
- Kinematic model
- Dynamical model
- Conclusion

Path planning

- Workspace and obstacles
- path planning

Mobile robotics

Visual servoing

RX90 robot

- Now that we can formulate the total torques acting on the joints in the configuration space due to the artificial potentials, we can formulate a path planning algorithm
 - First, determine your initial configuration
 - Second, given a desired point in the workspace, calculate the final configuration using the inverse kinematics: Use this to create an attractive potential field
 - Locate obstacles in the workspace: Create a repulsive potential field
 - Sum the joint torques in the configuration space
 - Use gradient descent to reach your target configuration

GRADIENT DESCENT

Robotics

N. Marchand

Introduction

Outline

Mechanics

Kinematics

Arm robots
 Inner-loop
 Geometrical model
 Kinematic model
 Dynamical model
 Conclusion

Path planning

Workspace and obstacles
 path planning

Mobile robotics

Visual servoing

RX90 robot

- 1 $i = 0, \theta[0] = \theta_0$
 - 2 if $\|\theta[i] - \theta_f\| > \varepsilon$,
 then:
 - $\theta[i + 1] = \theta[i] + \alpha[i] \frac{\tau(\theta[i])}{\|\tau(\theta[i])\|}$
 - $i = i + 1$
 - goto 2
- else:
- return $\theta[0], \dots, \theta[i]$

- Many other algorithms are possible
 - steepest descent (gradient) (Euler)
 - Newton
 - ... see optimization books
- the $\theta[0], \dots, \theta[i]$ are the successive configuration to track = path
- It is possible to add random to escape local minima



PROBABILISTIC ROADMAP

Robotics

N. Marchand

Introduction

Outline

Mechanics

Kinematics

Arm robots
Inner-loop
Geometrical
model
Kinematic model
Dynamical
model
Conclusion

Path planning

Workspace and
obstacles
path planning

Mobile
robotics

Visual
servoing

RX90 robot

- Randomly sample the configuration space

PROBABILISTIC ROADMAP

Robotics

N. Marchand

Introduction

Outline

Mechanics

Kinematics

- Arm robots
- Inner-loop
- Geometrical model
- Kinematic model
- Dynamical model
- Conclusion

Path planning

- Workspace and obstacles
- path planning**

Mobile robotics

Visual servoing

RX90 robot

- Randomly sample the configuration space
- Enables to roughly separate Q_f from O

PROBABILISTIC ROADMAP

Robotics

N. Marchand

Introduction

Outline

Mechanics

Kinematics

- Arm robots
- Inner-loop
- Geometrical model
- Kinematic model
- Dynamical model
- Conclusion

Path planning

- Workspace and obstacles
- path planning**

Mobile robotics

Visual servoing

RX90 robot

- Randomly sample the configuration space
- Enables to roughly separate Q_f from O
- Discards the points “too close” from O



PROBABILISTIC ROADMAP

Robotics

N. Marchand

Introduction

Outline

Mechanics

Kinematics

Arm robots
Inner-loop
Geometrical
model
Kinematic model
Dynamical
model
Conclusion

Path planning

Workspace and
obstacles
path planning

Mobile
robotics

Visual
servoing

RX90 robot

- Randomly sample the configuration space
- Enables to roughly separate Q_f from O
- Discards the points “too close” from O
- Connect using straight line segments that do not intersect obstacles



PROBABILISTIC ROADMAP

Robotics

N. Marchand

Introduction

Outline

Mechanics

Kinematics

Arm robots
Inner-loop
Geometrical
model
Kinematic model
Dynamical
model
Conclusion

Path planning

Workspace and
obstacles
path planning

Mobile
robotics

Visual
servoing

RX90 robot

- Randomly sample the configuration space
- Enables to roughly separate Q_f from O
- Discards the points “too close” from O
- Connect using straight line segments that do not intersect obstacles
- Eventually resample until Q_f is sufficiently covered



PROBABILISTIC ROADMAP

Robotics

N. Marchand

Introduction

Outline

Mechanics

Kinematics

Arm robots
Inner-loop
Geometrical model
Kinematic model
Dynamical model
Conclusion

Path planning

Workspace and obstacles
path planning

Mobile robotics

Visual servoing

RX90 robot

- Randomly sample the configuration space
- Enables to roughly separate Q_f from O
- Discards the points “too close” from O
- Connect using straight line segments that do not intersect obstacles
- Eventually resample until Q_f is sufficiently covered
- Chose the path in the connected space



SOME FINAL REMARKS

- All the previous methods assume an a priori knowledge of the environment

Robotics

N. Marchand

Introduction

Outline

Mechanics

Kinematics

Arm robots
Inner-loop
Geometrical
model
Kinematic model
Dynamical
model
Conclusion

Path planning

Workspace and
obstacles
path planning

Mobile
robotics

Visual
servoing

RX90 robot



SOME FINAL REMARKS

Robotics

N. Marchand

Introduction

Outline

Mechanics

Kinematics

Arm robots
Inner-loop
Geometrical
model
Kinematic model
Dynamical
model
Conclusion

Path planning

Workspace and
obstacles
path planning

Mobile robotics

Visual servoing

RX90 robot

- All the previous methods assume an a priori knowledge of the environment
- Predictive control can also be used to handle constraints “on line”

SOME FINAL REMARKS

Robotics

N. Marchand

Introduction

Outline

Mechanics

Kinematics

Arm robots
Inner-loop
Geometrical
model
Kinematic model
Dynamical
model
Conclusion

Path planning

Workspace and
obstacles
path planning

Mobile robotics

Visual servoing

RX90 robot

- All the previous methods assume an a priori knowledge of the environment
- Predictive control can also be used to handle constraints “on line”
- Adding fictive force is a very power tool also widely used in formation control or robotics with communication constraints (mainly range)

MOBILE ROBOTICS

Robotics

N. Marchand

Introduction

Outline

Mechanics

Kinematics

- Arm robots
- Inner-loop
- Geometrical model
- Kinematic model
- Dynamical model
- Conclusion

Path planning

- Workspace and obstacles
- path planning

Mobile robotics

Visual servoing

RX90 robot

- Born in the 50s, aiming to *autonomously moving* robots

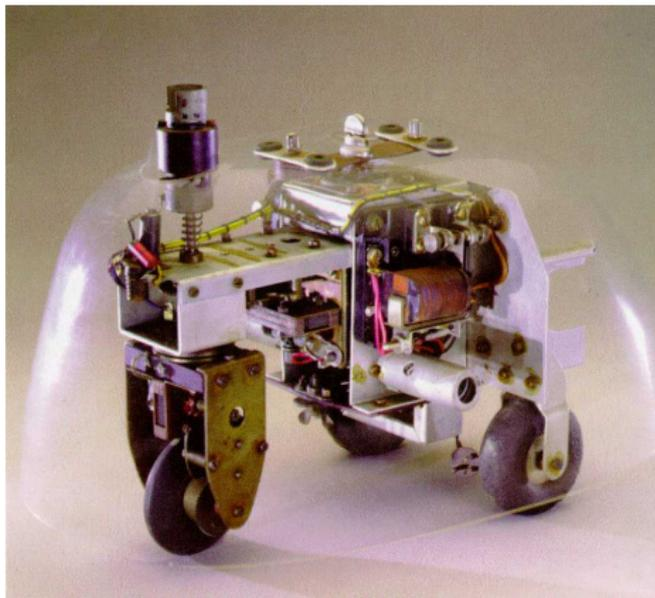

Grey Walter's "Turtle" (machina speculatrix): attracted by light

MOBILE ROBOTICS

Robotics

N. Marchand

Introduction

Outline

Mechanics

Kinematics

Arm robots

Inner-loop

Geometrical
model

Kinematic model

Dynamical
model

Conclusion

Path planning

Workspace and
obstacles

path planning

Mobile
robotics

Visual
servoing

RX90 robot

- Born in the 50s, aiming to autonomous mobile robots

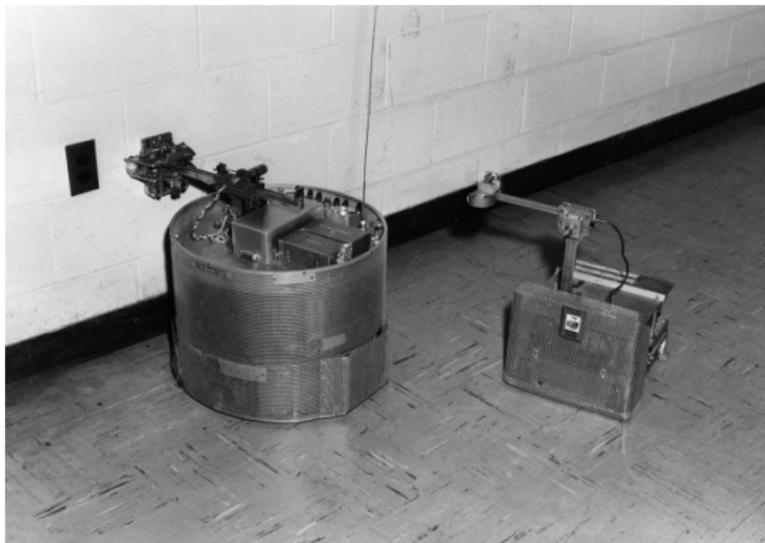

John Hopkins Univ. "Beast" robot: first use of transistor based sensing (ultrasound and photodiodes)

Robotics

N. Marchand

- Born in the 50s, aiming to autonomous mobile robots

Introduction

Outline

Mechanics

Kinematics

Arm robots
 Inner-loop
 Geometrical model
 Kinematic model
 Dynamical model
 Conclusion

Path planning

Workspace and obstacles
 path planning

Mobile robotics

Visual servoing

RX90 robot



Shakey robot from Stanford Univ.



MOBILE ROBOTICS

Robotics

N. Marchand

Introduction

Outline

Mechanics

Kinematics

- Arm robots
- Inner-loop
- Geometrical model
- Kinematic model
- Dynamical model
- Conclusion

Path planning

- Workspace and obstacles
- path planning

Mobile robotics

Visual servoing

RX90 robot

- Bio inspired locomotion: first biped robot



Honda E0 first biped robot (1986)

MOBILE ROBOTICS

Robotics

- Bio inspired locomotion: first biped walk

N. Marchand

Introduction

Outline

Mechanics

Kinematics

- Arm robots
- Inner-loop
- Geometrical model
- Kinematic model
- Dynamical model
- Conclusion

Path planning

- Workspace and obstacles
- path planning

Mobile robotics

Visual servoing

RX90 robot



Rabbit robot CNRS-Grenoble (2004)

MOBILE ROBOTICS

Robotics

N. Marchand

Introduction

Outline

Mechanics

Kinematics

- Arm robots
- Inner-loop
- Geometrical model
- Kinematic model
- Dynamical model
- Conclusion

Path planning

- Workspace and obstacles
- path planning

Mobile robotics

Visual servoing

RX90 robot

- Bio inspired locomotion: more about mobility



Boston Dynamics (SoftBank)

MOBILE ROBOTICS

Robotics

N. Marchand

Introduction

Outline

Mechanics

Kinematics

- Arm robots
- Inner-loop
- Geometrical model
- Kinematic model
- Dynamical model
- Conclusion

Path planning

- Workspace and obstacles
- path planning

Mobile robotics

Visual servoing

RX90 robot

- SLAM: Simultaneous localization and mapping



<https://github.com/erik-nelson/blam>



MOBILE ROBOTICS

Robotics

N. Marchand

Introduction

Outline

Mechanics

Kinematics

Arm robots
Inner-loop
Geometrical model
Kinematic model
Dynamical model
Conclusion

Path planning

Workspace and obstacles
path planning

Mobile
robotics

Visual
servoing

RX90 robot

- SLAM: Simultaneous localization and mapping



Robotics

N. Marchand

Introduction

Outline

Mechanics

Kinematics

- Arm robots
- Inner-loop
- Geometrical model
- Kinematic model
- Dynamical model
- Conclusion

Path planning

- Workspace and obstacles
- path planning

Mobile robotics

Visual servoing

RX90 robot

- Aerial robotics





MOBILE ROBOTICS

Robotics

N. Marchand

Introduction

Outline

Mechanics

Kinematics

Arm robots
Inner-loop
Geometrical
model
Kinematic model
Dynamical
model
Conclusion

Path planning

Workspace and
obstacles
path planning

Mobile
robotics

Visual
servoing

RX90 robot

- Bionics





INTRODUCTION TO VISUAL SERVOING

Robotics

- An arm robot equipped with a camera

N. Marchand

Introduction

Outline

Mechanics

Kinematics

Arm robots
Inner-loop
Geometrical
model
Kinematic model
Dynamical
model
Conclusion

Path planning

Workspace and
obstacles
path planning

Mobile
robotics

Visual
servoing

RX90 robot



INTRODUCTION TO VISUAL SERVOING

Robotics

- An arm robot equipped with a camera
- Aim: bring the final effector to a given predefined configuration

N. Marchand

Introduction

Outline

Mechanics

Kinematics

Arm robots
Inner-loop
Geometrical
model
Kinematic model
Dynamical
model
Conclusion

Path planning

Workspace and
obstacles
path planning

Mobile
robotics

Visual
servoing

RX90 robot



INTRODUCTION TO VISUAL SERVOING

Robotics

N. Marchand

Introduction

Outline

Mechanics

Kinematics

Arm robots
Inner-loop
Geometrical
model
Kinematic model
Dynamical
model
Conclusion

Path planning

Workspace and
obstacles
path planning

Mobile
robotics

Visual
servoing

RX90 robot

- An arm robot equipped with a camera
- Aim: bring the final effector to a given predefined configuration
- The configuration is defined by a *final* image feature to reach



INTRODUCTION TO VISUAL SERVOING

Robotics

N. Marchand

Introduction

Outline

Mechanics

Kinematics

Arm robots
Inner-loop
Geometrical
model
Kinematic model
Dynamical
model
Conclusion

Path planning

Workspace and
obstacles
path planning

Mobile
robotics

Visual
servoing

RX90 robot

- An arm robot equipped with a camera
- Aim: bring the final effector to a given predefined configuration
- The configuration is defined by a *final* image feature to reach
- Two possible configurations



INTRODUCTION TO VISUAL SERVOING

Robotics

N. Marchand

Introduction

Outline

Mechanics

Kinematics

Arm robots
Inner-loop
Geometrical
model
Kinematic model
Dynamical
model
Conclusion

Path planning

Workspace and
obstacles
path planning

Mobile robotics

Visual servoing

RX90 robot

- An arm robot equipped with a camera
- Aim: bring the final effector to a given predefined configuration
- The configuration is defined by a *final* image feature to reach
- Two possible configurations
- **Eye in hand** configuration

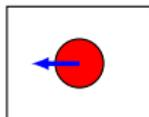
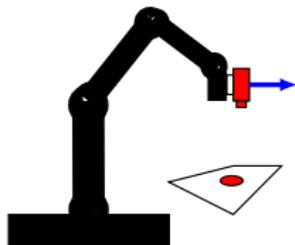

INTRODUCTION TO VISUAL SERVOING

Robotics

- An arm robot equipped with a camera
- Aim: bring the final effector to a given predefined configuration
- The configuration is defined by a *final* image feature to reach
- Two possible configurations

N. Marchand

Introduction

Outline

Mechanics

Kinematics

- Arm robots
- Inner-loop
- Geometrical model
- Kinematic model
- Dynamical model
- Conclusion

Path planning

- Workspace and obstacles
- path planning

Mobile robotics

Visual servoing

RX90 robot

- Eye in hand configuration

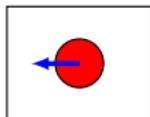
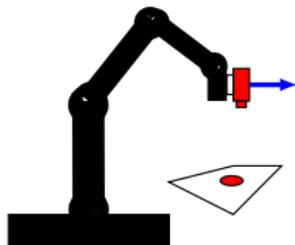

- Eye to hand configuration

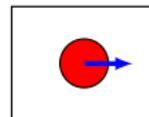
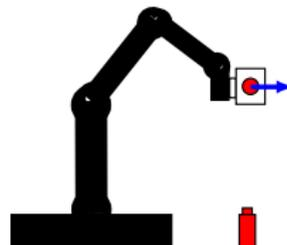

INTRODUCTION TO VISUAL SERVOING

The key points

Robotics

N. Marchand

Introduction

Outline

Mechanics

Kinematics

- Arm robots
- Inner-loop
- Geometrical model
- Kinematic model
- Dynamical model
- Conclusion

Path planning

- Workspace and obstacles
- path planning

Mobile robotics

Visual servoing

RX90 robot

- Being able to extract feature from the image: "recognize" points of the object
- Being able to characterize the relation between the robot movement and the image changes

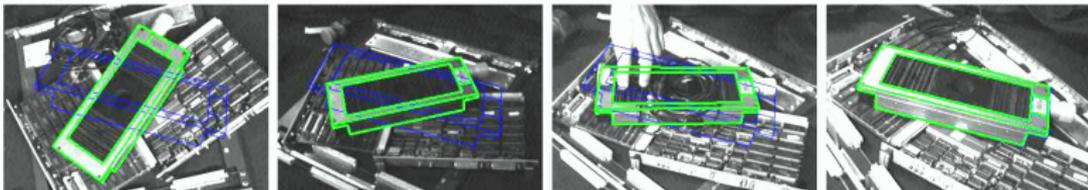



IMAGE BASED VISUAL SERVOING

THE INTERACTION MATRIX

Robotics

N. Marchand

Introduction

Outline

Mechanics

Kinematics

Arm robots

Inner-loop

Geometrical
model

Kinematic model

Dynamical
model

Conclusion

Path planning

Workspace and
obstacles

path planning

Mobile

robotics

Visual

servoing

RX90 robot

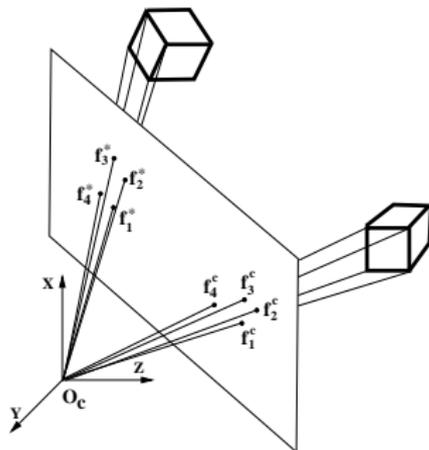

The interaction matrix links the movement of O_c (lateral and rotational) to the movement of the feature points (f_i^c)

INTRODUCTION TO VISUAL SERVOING

A short mathematical background

Robotics

N. Marchand

- Positioning error:

$$e(t) = s(q(t), a) - s^*$$

Introduction

Outline

Mechanics

Kinematics

Arm robots
Inner-loop
Geometrical
model
Kinematic model
Dynamical
model
Conclusion

Path planning

Workspace and
obstacles
path planning

Mobile
robotics

Visual
servoing

RX90 robot

INTRODUCTION TO VISUAL SERVOING

A short mathematical background

Robotics

N. Marchand

Introduction

Outline

Mechanics

Kinematics

Arm robots
Inner-loop
Geometrical
model
Kinematic model
Dynamical
model
Conclusion

Path planning

Workspace and
obstacles
path planning

Mobile
robotics

Visual
servoing

RX90 robot

- Positioning error:

$$e(t) = s(q(t), a) - s^*$$

- s denotes the current feature depending upon

INTRODUCTION TO VISUAL SERVOING

A short mathematical background

Robotics

N. Marchand

Introduction

Outline

Mechanics

Kinematics

Arm robots

Inner-loop

Geometrical
model

Kinematic model

Dynamical
model

Conclusion

Path planning

Workspace and
obstacles

path planning

Mobile

robotics

Visual

servoing

RX90 robot

- Positioning error:

$$e(t) = s(q(t), a) - s^*$$

- s denotes the current feature depending upon
 - the robot configuration $q(t)$

INTRODUCTION TO VISUAL SERVOING

A short mathematical background

Robotics

N. Marchand

Introduction

Outline

Mechanics

Kinematics

Arm robots
Inner-loop
Geometrical model
Kinematic model
Dynamical model
Conclusion

Path planning

Workspace and obstacles
path planning

Mobile robotics

Visual servoing

RX90 robot

- Positioning error:

$$e(t) = s(q(t), a) - s^*$$

- s denotes the current feature depending upon
 - the robot configuration $q(t)$
 - a set of parameters a gathering all additional information (coarse camera intrinsic parameters, three-dimensional model of objects, etc.)



INTRODUCTION TO VISUAL SERVOING

A short mathematical background

Robotics

N. Marchand

Introduction

Outline

Mechanics

Kinematics

Arm robots

Inner-loop

Geometrical
model

Kinematic model

Dynamical
model

Conclusion

Path planning

Workspace and
obstacles

path planning

Mobile

robotics

Visual

servoing

RX90 robot

- Positioning error:

$$e(t) = s(q(t), a) - s^*$$

- s denotes the current feature depending upon
 - the robot configuration $q(t)$
 - a set of parameters a gathering all additional information (coarse camera intrinsic parameters, three-dimensional model of objects, etc.)
- s^* denotes the target feature



INTRODUCTION TO VISUAL SERVOING

A short mathematical background

Robotics

N. Marchand

Introduction

Outline

Mechanics

Kinematics

Arm robots

Inner-loop

Geometrical
model

Kinematic model

Dynamical
model

Conclusion

Path planning

Workspace and
obstacles

path planning

Mobile

robotics

Visual

servoing

RX90 robot

- Positioning error:

$$e(t) = s(q(t), a) - s^*$$

- s denotes the current feature depending upon
 - the robot configuration $q(t)$
 - a set of parameters a gathering all additional information (coarse camera intrinsic parameters, three-dimensional model of objects, etc.)
- s^* denotes the target feature
- The relation between the image and the real world is given by the **interaction matrix**:

$$\dot{s} = L_s \nu_c$$

where

INTRODUCTION TO VISUAL SERVOING

A short mathematical background

Robotics

N. Marchand

Introduction

Outline

Mechanics

Kinematics

Arm robots

Inner-loop

Geometrical model

Kinematic model

Dynamical model

Conclusion

Path planning

Workspace and obstacles

path planning

Mobile robotics

Visual servoing

RX90 robot

- Positioning error:

$$e(t) = s(q(t), a) - s^*$$

- s denotes the current feature depending upon
 - the robot configuration $q(t)$
 - a set of parameters a gathering all additional information (coarse camera intrinsic parameters, three-dimensional model of objects, etc.)
- s^* denotes the target feature
- The relation between the image and the real world is given by the **interaction matrix**:

$$\dot{s} = L_s \nu_c$$

where

- $\nu_c := (v_c, \omega_c) = (\text{linear veloc}_{\text{cam frame}}, \text{angular veloc}_{\text{cam frame}})$

INTRODUCTION TO VISUAL SERVOING

A short mathematical background

Robotics

N. Marchand

Introduction

Outline

Mechanics

Kinematics

Arm robots

Inner-loop

Geometrical model

Kinematic model

Dynamical model

Conclusion

Path planning

Workspace and obstacles

path planning

Mobile robotics

Visual servoing

RX90 robot

- Positioning error:

$$e(t) = s(q(t), a) - s^*$$

- s denotes the current feature depending upon
 - the robot configuration $q(t)$
 - a set of parameters a gathering all additional information (coarse camera intrinsic parameters, three-dimensional model of objects, etc.)
- s^* denotes the target feature
- The relation between the image and the real world is given by the **interaction matrix**:

$$\dot{s} = L_s \nu_c$$

where

- $\nu_c := (v_c, \omega_c) = (\text{linear vel}_{\text{cam frame}}, \text{angular vel}_{\text{cam frame}})$
- $L_s \in \mathbb{R}^{k \times 6}$: interaction matrix (Jacobian)

CONTROL IN VISUAL SERVOING

A simple control approach

- Coupling the error and the interaction relation, one gets:

$$\dot{e} = L_s \nu_c$$

Robotics

N. Marchand

Introduction

Outline

Mechanics

Kinematics

Arm robots

Inner-loop

Geometrical
model

Kinematic model

Dynamical
model

Conclusion

Path planning

Workspace and
obstacles

path planning

Mobile

robotics

Visual

servoing

RX90 robot



CONTROL IN VISUAL SERVOING

A simple control approach

- Coupling the error and the interaction relation, one gets:

$$\dot{e} = L_S \nu_C$$

- Take the linear velocities and angular velocities as control variable

Robotics

N. Marchand

Introduction

Outline

Mechanics

Kinematics

Arm robots

Inner-loop

Geometrical
model

Kinematic model

Dynamical
model

Conclusion

Path planning

Workspace and
obstacles

path planning

Mobile

robotics

Visual

servoing

RX90 robot



CONTROL IN VISUAL SERVOING

A simple control approach

Robotics

N. Marchand

Introduction

Outline

Mechanics

Kinematics

Arm robots
 Inner-loop
 Geometrical
 model
 Kinematic model
 Dynamical
 model
 Conclusion

Path planning

Workspace and
 obstacles
 path planning

Mobile robotics

Visual servoing

RX90 robot

- Coupling the error and the interaction relation, one gets:

$$\dot{e} = L_S \nu_C$$

- Take the linear velocities and angular velocities as control variable
- Let $L_S^+ := (L_S^T L_S)^{-1} L_S^T$ be the Moore–Penrose pseudo-inverse of L_S



CONTROL IN VISUAL SERVOING

A simple control approach

Robotics

N. Marchand

Introduction

Outline

Mechanics

Kinematics

- Arm robots
- Inner-loop
- Geometrical model
- Kinematic model
- Dynamical model
- Conclusion

Path planning

- Workspace and obstacles
- path planning

Mobile robotics

Visual servoing

RX90 robot

- Coupling the error and the interaction relation, one gets:

$$\dot{e} = L_s \nu_c$$

- Take the linear velocities and angular velocities as control variable
- Let $L_s^+ := (L_s^T L_s)^{-1} L_s^T$ be the Moore–Penrose pseudo-inverse of L_s
- To force an exponential decrease of the error:

$$\dot{e} = -\lambda e$$

we must chose

$$\nu_c := -\lambda L_s^+ e$$



CONTROL IN VISUAL SERVOING

A simple control approach

Robotics

N. Marchand

Introduction

Outline

Mechanics

Kinematics

Arm robots
Inner-loop
Geometrical
model
Kinematic model
Dynamical
model
Conclusion

Path planning

Workspace and
obstacles
path planning

Mobile
robotics

Visual
servoing

RX90 robot

- Coupling the error and the interaction relation, one gets:

$$\dot{e} = L_S \nu_C$$

- Take the linear velocities and angular velocities as control variable
- Let $L_S^+ := (L_S^T L_S)^{-1} L_S^T$ be the Moore–Penrose pseudo-inverse of L_S
- To force an exponential decrease of the error:

$$\dot{e} = -\lambda e$$

we must chose

$$\nu_C := -\lambda L_S^+ e$$

- Practically, L_S is never known perfectly and we use an approximation

IMAGE-BASED VISUAL SERVOING

Robotics

N. Marchand

- Take a 3D point of coordinates $P = (X, Y, Z)$ in the camera frame

Introduction

Outline

Mechanics

Kinematics

Arm robots
Inner-loop
Geometrical model
Kinematic model
Dynamical model
Conclusion

Path planning

Workspace and obstacles
path planning

Mobile robotics

Visual servoing

RX90 robot

IMAGE-BASED VISUAL SERVOING

Robotics

N. Marchand

Introduction

Outline

Mechanics

Kinematics

Arm robots

Inner-loop

Geometrical
model

Kinematic model

Dynamical
model

Conclusion

Path planning

Workspace and
obstacles

path planning

Mobile

robotics

Visual

servoing

RX90 robot

- Take a 3D point of coordinates $P = (X, Y, Z)$ in the camera frame
- Its coordinates in the image will be $p = (x, y)$:

$$x = X/Z = (u - c_u)/f\alpha$$

$$y = Y/Z = (v - c_v)/f$$

where f is the focal length, α is the ratio of the pixel dimensions, c_u and c_v are the coordinates of the principal point.

IMAGE-BASED VISUAL SERVOING

Robotics

- Take a 3D point of coordinates $P = (X, Y, Z)$ in the camera frame
- Its coordinates in the image will be $p = (x, y)$:

$$x = X/Z = (u - c_u)/f\alpha$$

$$y = Y/Z = (v - c_v)/f$$

where f is the focal length, α is the ratio of the pixel dimensions, c_u and c_v are the coordinates of the principal point.

- Derivating, we get

$$\dot{x} = \dot{X}/Z - X\dot{Z}/Z^2 = (\dot{X} - x\dot{Z})/Z$$

$$\dot{y} = \dot{Y}/Z - Y\dot{Z}/Z^2 = (\dot{Y} - y\dot{Z})/Z$$

- Introduction
- Outline
- Mechanics
- Kinematics
 - Arm robots
 - Inner-loop
 - Geometrical model
 - Kinematic model
 - Dynamical model
 - Conclusion
- Path planning
 - Workspace and obstacles
 - path planning
- Mobile robotics
- Visual servoing
- RX90 robot



IMAGE-BASED VISUAL SERVOING

Robotics

- Using the Varignon's formula

$$\dot{X} = -v_c - \omega_c^X X$$

N. Marchand

Introduction

Outline

Mechanics

Kinematics

- Arm robots
- Inner-loop
- Geometrical model
- Kinematic model
- Dynamical model
- Conclusion

Path planning

- Workspace and obstacles
- path planning

Mobile robotics

Visual servoing

RX90 robot



IMAGE-BASED VISUAL SERVOING

Robotics

- Using the Varignon's formula

$$\dot{X} = -v_c - \omega_c^x X$$

- Mixing the two last equation, we get the interaction matrix form P

$$\dot{p} = L_p v_c$$

with

$$L_p = \begin{pmatrix} -1/Z & 0 & x/Z & xy & -(1+x^2) & y \\ 0 & -1/Z & y/Z & 1+y^2 & -xy & -x \end{pmatrix}$$

N. Marchand

Introduction

Outline

Mechanics

Kinematics

Arm robots

Inner-loop

Geometrical
model

Kinematic model

Dynamical
model

Conclusion

Path planning

Workspace and
obstacles

path planning

Mobile

robotics

Visual

servoing

RX90 robot

IMAGE-BASED VISUAL SERVOING

Robotics

- Using the Varignon's formula

$$\dot{X} = -v_c - \omega_c^{\times} X$$

- Mixing the two last equation, we get the interaction matrix form P

$$\dot{p} = L_p v_c$$

with

$$L_p = \begin{pmatrix} -1/Z & 0 & x/Z & xy & -(1+x^2) & y \\ 0 & -1/Z & y/Z & 1+y^2 & -xy & -x \end{pmatrix}$$

- Z is the depth and is usually not known

N. Marchand

Introduction

Outline

Mechanics

Kinematics

Arm robots

Inner-loop

Geometrical model

Kinematic model

Dynamical model

Conclusion

Path planning

Workspace and obstacles

path planning

Mobile

robotics

Visual

servoing

RX90 robot



IMAGE-BASED VISUAL SERVOING

Robotics

N. Marchand

Introduction

Outline

Mechanics

Kinematics

Arm robots

Inner-loop

Geometrical
model

Kinematic model

Dynamical
model

Conclusion

Path planning

Workspace and
obstacles

path planning

Mobile

robotics

Visual

servoing

RX90 robot

- Using the Varignon's formula

$$\dot{X} = -v_c - \omega_c^{\times} X$$

- Mixing the two last equation, we get the interaction matrix form P

$$\dot{p} = L_p v_c$$

with

$$L_p = \begin{pmatrix} -1/Z & 0 & x/Z & xy & -(1+x^2) & y \\ 0 & -1/Z & y/Z & 1+y^2 & -xy & -x \end{pmatrix}$$

- Z is the depth and is usually not known
- To control six degrees of freedom, at least three points are required (p_1, p_2, p_3)



IMAGE-BASED VISUAL SERVOING

Robotics

- Using the Varignon's formula

$$\dot{X} = -v_c - \omega_c^{\times} X$$

- Mixing the two last equation, we get the interaction matrix form P

$$\dot{p} = L_p v_c$$

with

$$L_p = \begin{pmatrix} -1/Z & 0 & x/Z & xy & -(1+x^2) & y \\ 0 & -1/Z & y/Z & 1+y^2 & -xy & -x \end{pmatrix}$$

- Z is the depth and is usually not known
- To control six degrees of freedom, at least three points are required (p_1, p_2, p_3)
- Camera parameters can be obtained by calibration

N. Marchand

Introduction

Outline

Mechanics

Kinematics

Arm robots

Inner-loop

Geometrical model

Kinematic model

Dynamical model

Conclusion

Path planning

Workspace and obstacles

path planning

Mobile

robotics

Visual

servoing

RX90 robot



IMAGE-BASED VISUAL STEREO SERVOING

Robotics

N. Marchand

Introduction

Outline

Mechanics

Kinematics

Arm robots
Inner-loop
Geometrical
model
Kinematic model
Dynamical
model
Conclusion

Path planning

Workspace and
obstacles
path planning

Mobile
robotics

Visual
servoing

RX90 robot

- We assume now that we have two cameras



STÄUBLI RX90 ROBOT

Robotics

N. Marchand

Introduction

Outline

Mechanics

Kinematics

Arm robots

Inner-loop

Geometrical
model

Kinematic model

Dynamical
model

Conclusion

Path planning

Workspace and
obstacles

path planning

Mobile
robotics

Visual
servoing

RX90 robot

- 6 angles with constraints:

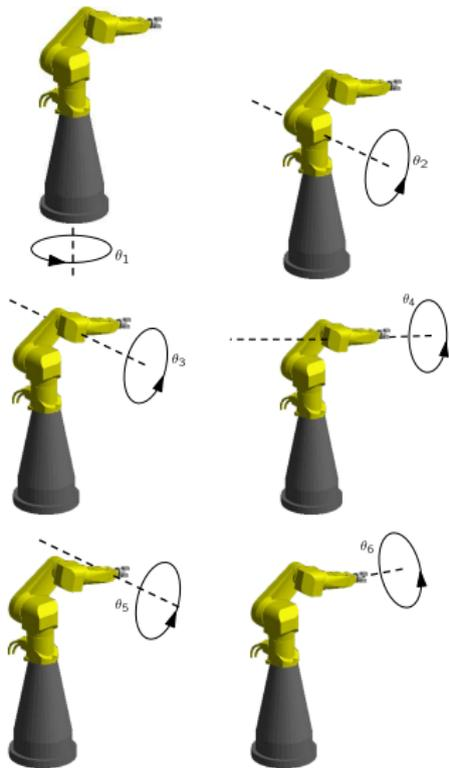



STÄUBLI RX90 ROBOT

Robotics

N. Marchand

Introduction

Outline

Mechanics

Kinematics

Arm robots

Inner-loop

Geometrical
model

Kinematic model

Dynamical
model

Conclusion

Path planning

Workspace and
obstacles

path planning

Mobile
robotics

Visual
servoing

RX90 robot

- 6 angles with constraints:
 - $-160 \leq \theta_1 \leq 160$: waist angle

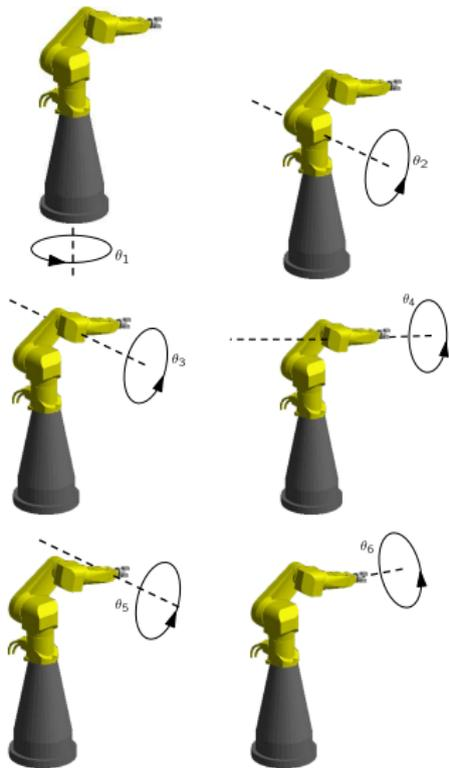



STÄUBLI RX90 ROBOT

Robotics

N. Marchand

Introduction

Outline

Mechanics

Kinematics

Arm robots

Inner-loop

Geometrical
model

Kinematic model

Dynamical
model

Conclusion

Path planning

Workspace and
obstacles

path planning

Mobile
robotics

Visual
servoing

RX90 robot

- 6 angles with constraints:
 - $-160 \leq \theta_1 \leq 160$: waist angle
 - $-120 \leq \theta_2 \leq 120$: shoulder angle

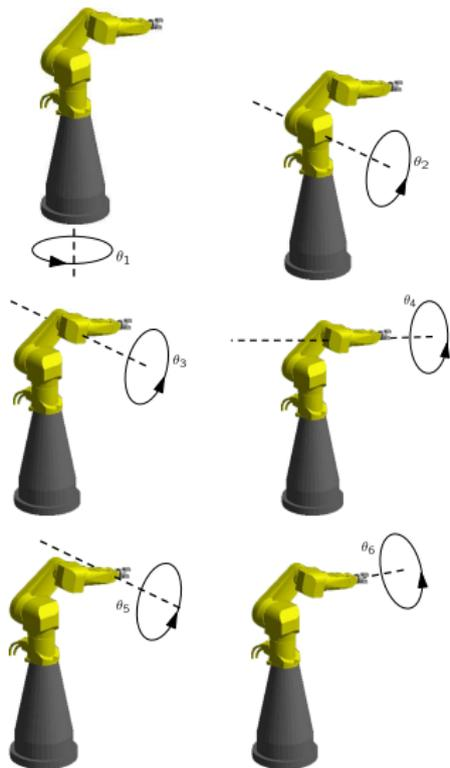



STÄUBLI RX90 ROBOT

Robotics

N. Marchand

Introduction

Outline

Mechanics

Kinematics

Arm robots

Inner-loop

Geometrical
model

Kinematic model

Dynamical
model

Conclusion

Path planning

Workspace and
obstacles

path planning

Mobile
robotics

Visual
servoing

RX90 robot

- 6 angles with constraints:

- $-160 \leq \theta_1 \leq 160$: waist angle
- $-120 \leq \theta_2 \leq 120$: shoulder angle
- $-135 \leq \theta_3 \leq 135$: elbow angle

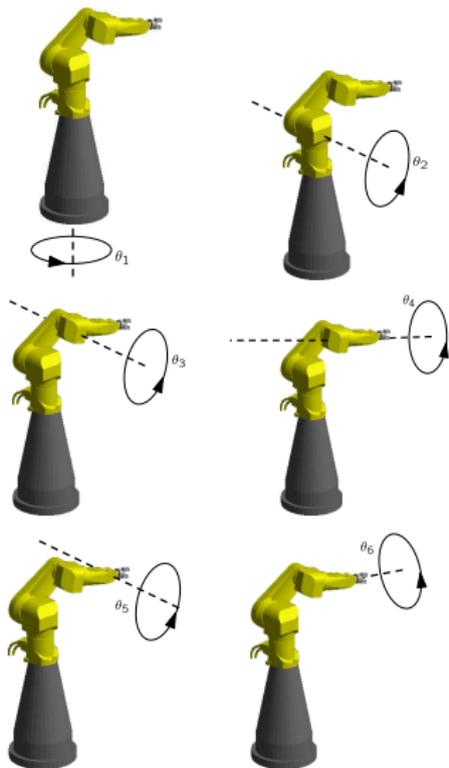

STÄUBLI RX90 ROBOT

Robotics

N. Marchand

Introduction

Outline

Mechanics

Kinematics

Arm robots

Inner-loop

Geometrical model

Kinematic model

Dynamical model

Conclusion

Path planning

Workspace and obstacles

path planning

Mobile robotics

Visual servoing

RX90 robot

- 6 angles with constraints:
 - $-160 \leq \theta_1 \leq 160$: waist angle
 - $-120 \leq \theta_2 \leq 120$: shoulder angle
 - $-135 \leq \theta_3 \leq 135$: elbow angle
 - $-266 \leq \theta_4 \leq 266$: wrist roll angle

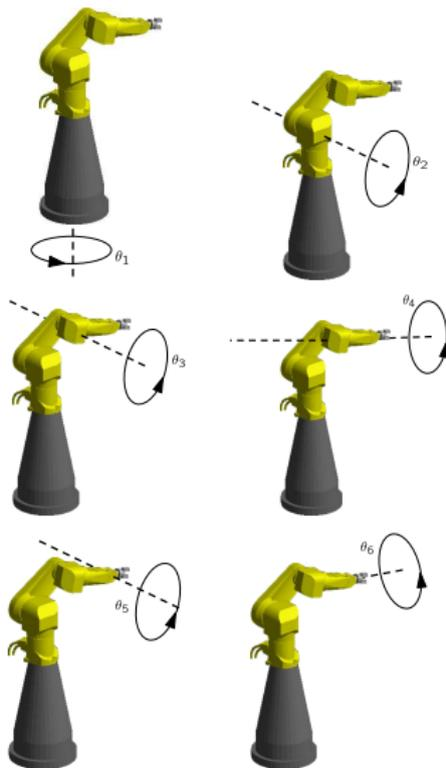

STÄUBLI RX90 ROBOT

Robotics

N. Marchand

Introduction

Outline

Mechanics

Kinematics

Arm robots

Inner-loop

Geometrical model

Kinematic model

Dynamical model

Conclusion

Path planning

Workspace and obstacles

path planning

Mobile robotics

robotics

Visual servoing

servoing

RX90 robot

● 6 angles with constraints:

- $-160 \leq \theta_1 \leq 160$: waist angle
- $-120 \leq \theta_2 \leq 120$: shoulder angle
- $-135 \leq \theta_3 \leq 135$: elbow angle
- $-266 \leq \theta_4 \leq 266$: wrist roll angle
- $-100 \leq \theta_5 \leq 100$: wrist bend angle

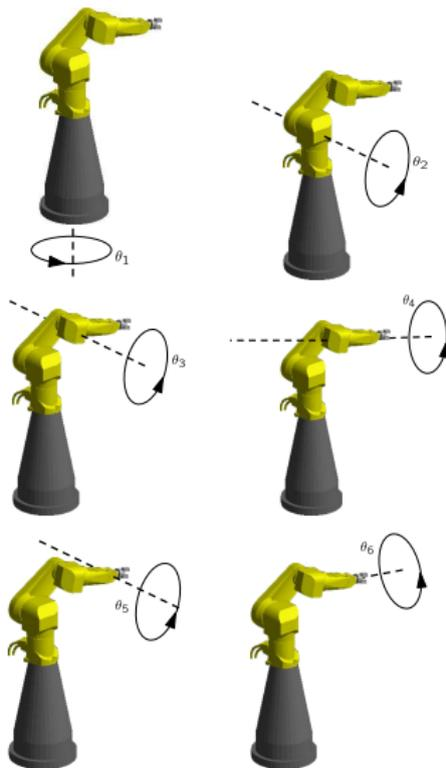

STÄUBLI RX90 ROBOT

Robotics

N. Marchand

Introduction

Outline

Mechanics

Kinematics

- Arm robots
- Inner-loop
- Geometrical model
- Kinematic model
- Dynamical model
- Conclusion

Path planning

- Workspace and obstacles
- path planning

Mobile robotics

Visual servoing

RX90 robot

● 6 angles with constraints:

- $-160 \leq \theta_1 \leq 160$: waist angle
- $-120 \leq \theta_2 \leq 120$: shoulder angle
- $-135 \leq \theta_3 \leq 135$: elbow angle
- $-266 \leq \theta_4 \leq 266$: wrist roll angle
- $-100 \leq \theta_5 \leq 100$: wrist bend angle
- $-266 \leq \theta_6 \leq 266$: wrist swivel angle

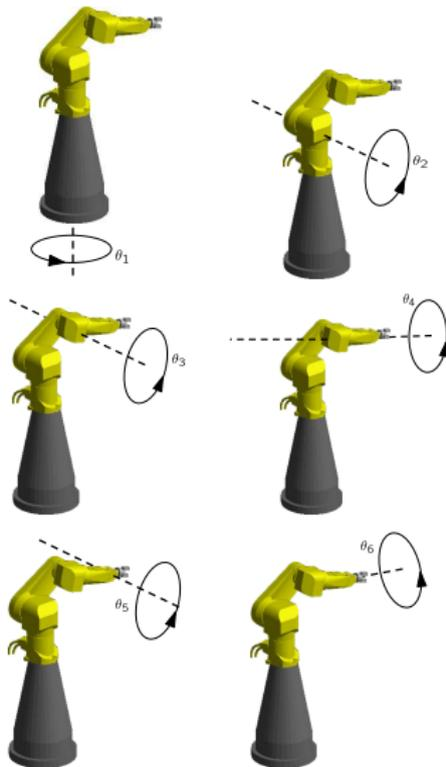

STÄUBLI RX90 ROBOT

Robotics

N. Marchand

Introduction

Outline

Mechanics

Kinematics

Arm robots

Inner-loop

Geometrical model

Kinematic model

Dynamical model

Conclusion

Path planning

Workspace and obstacles

path planning

Mobile robotics

Visual servoing

RX90 robot

- 6 angles with constraints:
 - $-160 \leq \theta_1 \leq 160$: waist angle
 - $-120 \leq \theta_2 \leq 120$: shoulder angle
 - $-135 \leq \theta_3 \leq 135$: elbow angle
 - $-266 \leq \theta_4 \leq 266$: wrist roll angle
 - $-100 \leq \theta_5 \leq 100$: wrist bend angle
 - $-266 \leq \theta_6 \leq 266$: wrist swivel angle
- Rest angles:

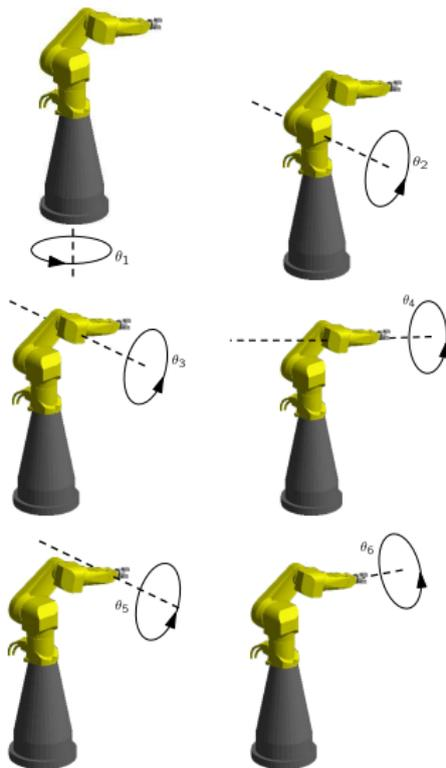

STÄUBLI RX90 ROBOT

Robotics

N. Marchand

Introduction

Outline

Mechanics

Kinematics

- Arm robots
- Inner-loop
- Geometrical model
- Kinematic model
- Dynamical model
- Conclusion

Path planning

- Workspace and obstacles
- path planning

Mobile robotics

Visual servoing

RX90 robot

- 6 angles with constraints:
 - $-160 \leq \theta_1 \leq 160$: waist angle
 - $-120 \leq \theta_2 \leq 120$: shoulder angle
 - $-135 \leq \theta_3 \leq 135$: elbow angle
 - $-266 \leq \theta_4 \leq 266$: wrist roll angle
 - $-100 \leq \theta_5 \leq 100$: wrist bend angle
 - $-266 \leq \theta_6 \leq 266$: wrist swivel angle
- Rest angles:
 - $\theta_{10} = 90$

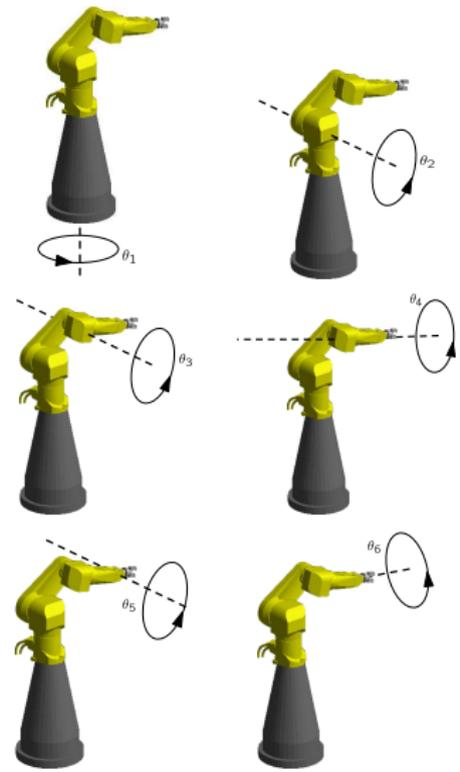

STÄUBLI RX90 ROBOT

Robotics

N. Marchand

Introduction

Outline

Mechanics

Kinematics

Arm robots

Inner-loop

Geometrical model

Kinematic model

Dynamical model

Conclusion

Path planning

Workspace and obstacles

path planning

Mobile robotics

Visual servoing

RX90 robot

- 6 angles with constraints:
 - $-160 \leq \theta_1 \leq 160$: waist angle
 - $-120 \leq \theta_2 \leq 120$: shoulder angle
 - $-135 \leq \theta_3 \leq 135$: elbow angle
 - $-266 \leq \theta_4 \leq 266$: wrist roll angle
 - $-100 \leq \theta_5 \leq 100$: wrist bend angle
 - $-266 \leq \theta_6 \leq 266$: wrist swivel angle
- Rest angles:
 - $\theta_{10} = 90$
 - $\theta_{20} = \theta_{30} = 90$

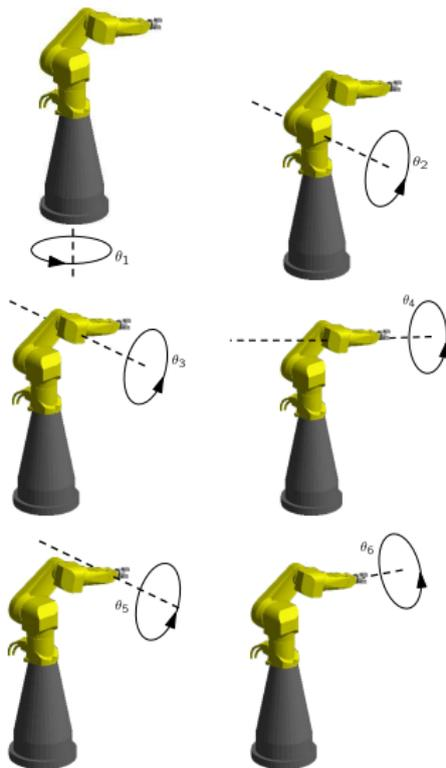

STÄUBLI RX90 ROBOT

Robotics

N. Marchand

Introduction

Outline

Mechanics

Kinematics

- Arm robots
- Inner-loop
- Geometrical model
- Kinematic model
- Dynamical model
- Conclusion

Path planning

- Workspace and obstacles
- path planning

Mobile robotics

Visual servoing

RX90 robot

- 6 angles with constraints:
 - $-160 \leq \theta_1 \leq 160$: waist angle
 - $-120 \leq \theta_2 \leq 120$: shoulder angle
 - $-135 \leq \theta_3 \leq 135$: elbow angle
 - $-266 \leq \theta_4 \leq 266$: wrist roll angle
 - $-100 \leq \theta_5 \leq 100$: wrist bend angle
 - $-266 \leq \theta_6 \leq 266$: wrist swivel angle
- Rest angles:
 - $\theta_{10} = 90$
 - $\theta_{20} = \theta_{30} = 90$
 - $\theta_{40} = \theta_{50} = \theta_{60} = 0$

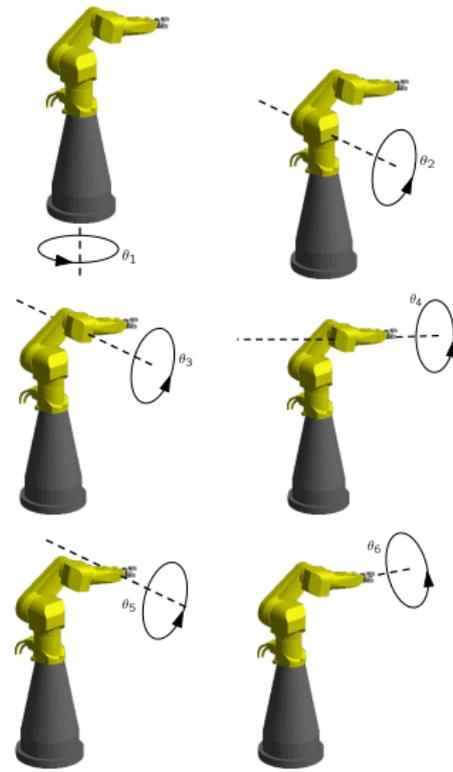



STÄUBLI RX90 ROBOT

Robotics

N. Marchand

Introduction

Outline

Mechanics

Kinematics

Arm robots

Inner-loop

Geometrical
model

Kinematic model

Dynamical
model

Conclusion

Path planning

Workspace and
obstacles

path planning

Mobile
robotics

Visual
servoing

RX90 robot

● Stäubli RX90 robot

d_0	d_1 177	a_1	d_2	a_2	d_3	d_4
-------	--------------	-------	-------	-------	-------	-------

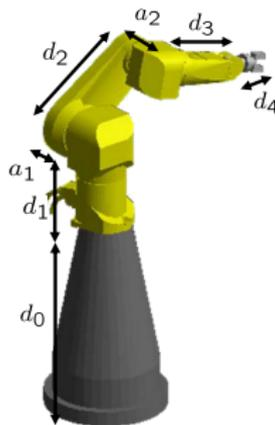

STÄUBLI RX90 ROBOT

Robotics

N. Marchand

Introduction

Outline

Mechanics

Kinematics

- Arm robots
- Inner-loop
- Geometrical model
- Kinematic model
- Dynamical model
- Conclusion

Path planning

- Workspace and obstacles
- path planning

Mobile robotics

Visual servoing

RX90 robot

- Stäubli RX90 robot
 - What are the number of DOF ?

d_0	d_1	a_1	d_2	a_2	d_3	d_4
	177					

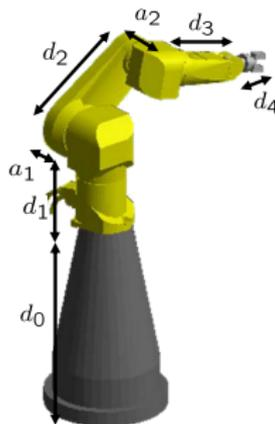

STÄUBLI RX90 ROBOT

Robotics

N. Marchand

Introduction

Outline

Mechanics

Kinematics

- Arm robots
- Inner-loop
- Geometrical model
- Kinematic model
- Dynamical model
- Conclusion

Path planning

- Workspace and obstacles
- path planning

Mobile robotics

Visual servoing

RX90 robot

- Stäubli RX90 robot
 - What are the number of DOF ?
 - Compute the forward kinematic (geometrical model) of the wrist

d_0	d_1	a_1	d_2	a_2	d_3	d_4
	177					

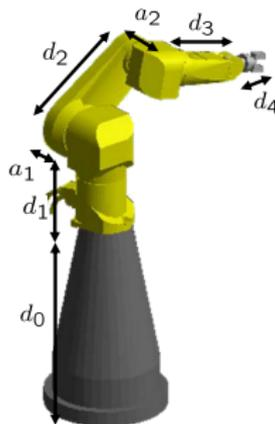

STÄUBLI RX90 ROBOT

Robotics

N. Marchand

Introduction

Outline

Mechanics

Kinematics

- Arm robots
- Inner-loop
- Geometrical model
- Kinematic model
- Dynamical model
- Conclusion

Path planning

- Workspace and obstacles
- path planning

Mobile robotics

Visual servoing

RX90 robot

- Stäubli RX90 robot
 - What are the number of DOF ?
 - Compute the forward kinematic (geometrical model) of the wrist
 - Compute the inverse kinematic

d_0	d_1	a_1	d_2	a_2	d_3	d_4
	177					

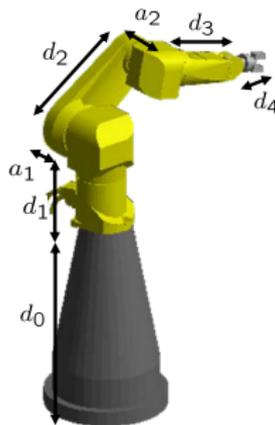



STÄUBLI RX90 ROBOT

Robotics

N. Marchand

Introduction

Outline

Mechanics

Kinematics

Arm robots
 Inner-loop
 Geometrical model
 Kinematic model
 Dynamical model
 Conclusion

Path planning

Workspace and obstacles
 path planning

Mobile robotics

Visual servoing

RX90 robot

- 1 Compute U_{att} and U_{rep} as function of the current position $p = (x, y, z)$ and the desired final position $p_f = (x_f, y_f, z_f)$
- 2 Compute $U(p, p_f) = U_{att} + U_{rep} \in \mathbb{R}^+$
- 3 Compute $\nabla U \in R^3$, the derivative of U w.r.t. p
 - ∇U can be computed analytically
 - ∇U can be computed numerically for ε small:

$$\nabla U \approx \begin{pmatrix} \frac{U(x - \varepsilon, y, z, p_f) - U(x + \varepsilon, y, z, p_f)}{2\varepsilon} \\ \frac{U(x, y - \varepsilon, z, p_f) - U(x, y + \varepsilon, z, p_f)}{2\varepsilon} \\ \frac{U(x, y, z - \varepsilon, p_f) - U(x, y, z + \varepsilon, p_f)}{2\varepsilon} \end{pmatrix}$$

- 4 Program an iterative routine with the following iteration:

$$p_{k+1} = p_k - \gamma \nabla U(p_k, p_f)$$

- 5 Start the program at your initial position p_0 and stop the program when p_k is close to p_f
- 6 The successive p_0, p_1, \dots give you the path